



U.S. Department
of Transportation
**National Highway
Traffic Safety
Administration**

DOT-TSC-NHTSA-88-4
Final Report

September, 1988

Appendix H: Study of Mechanical and Driver - Related Systems of the Audi 5000 Capable of Producing Uncontrolled Sudden Acceleration Incidents

Gary Carr
John Pollard
Don Sussman
Robert Walter
Herbert Weinstock

U.S. Department of Transportation
Research and Special Programs
Administration
Transportation Systems Center
Cambridge, MA 02142

Prepared for
National Highway Traffic Safety Administration
Office of Defects Investigation
400 7th Street, SW
Washington, DC 20590

1. Report No.	2. Government Accession No.	3. Recipient's Catalog No.	
4. Title and Subtitle STUDY OF MECHANICAL AND DRIVER-RELATED SYSTEMS OF THE AUDI 5000 CAPABLE OF PRODUCING UNCONTROLLED SUDDEN ACCELERATION INCIDENTS		5. Report Date December 1988	6. Performing Organization Code DTS-45
7. Author(s) Robert Walter, Gary Carr, Herbert Weinstock, Don Sussman, John Pollard		8. Performing Organization Report No. DOT-TSC-NHTSA-88-4	
9. Performing Organization Name and Address Department of Transportation Transportation Systems Center Kendall Square Cambridge, MA 02142		10. Work Unit No. (TRAI5) HS910/S9024	11. Contract or Grant No.
12. Sponsoring Agency Name and Address National Highway Traffic Safety Administration Office of Defects Investigation 400 7th Street, SW Washington, DC 20590		13. Type of Report and Period Covered Final Report Jan. 1987 - Dec. 1988	
15. Supplementary Notes		14. Sponsoring Agency Code NEF10	
<p>The rate of Sudden Acceleration Incident (SAI) complaints received by NHTSA for the Audi 5000 has been unusually high. SAI complaints characteristically report unanticipated full-power acceleration which can not be controlled by braking.</p> <p>The report discusses the possible contributions of the subject vehicle and the driver to the complaint rate. It reviews prior investigations of the Audi 5000 and describes new engineering and statistical analyses conducted to gain insights into the possible causes of SAI. The report discusses the engine system, transmission, brakes, controls, and driver demographics. The possible contribution of driver pedal misapplication was examined in terms of driving environment, driver population, type of driving and driving experience.</p> <p>Among the principal conclusions were: 1) Some versions of Audi idle-stabilization system were prone to defects which resulted in excessive idle speeds and brief unanticipated accelerations of up to 0.3g. These accelerations could not be the sole cause of SAIs, but might have triggered some SAIs by startling the driver. 2) The pedal and seating arrangements of the Audi are significantly different from larger domestic cars. These differences may contribute to a higher incidence of pedal misapplication, especially for relatively unfamiliar drivers. 3) Brake failures are very unlikely and would be detectable after the event if they occurred.</p>			
17. Key Words Sudden Acceleration Incident, Audi 5000 Braking, Idle-stabilizer, Pedal Misapplication		18. Distribution Statement DOCUMENT IS AVAILABLE TO THE PUBLIC THROUGH THE NATIONAL TECHNICAL INFORMATION SERVICE, SPRINGFIELD VIRGINIA 22161	
19. Security Classif. (of this report) UNCLASSIFIED	20. Security Classif (of this page) UNCLASSIFIED	21. No. of Pages	22. Price

PREFACE

This report was prepared by the U.S. Department of Transportation, Transportation Systems Center (TSC) for the National Highway Traffic Safety Administration Office of Defects Investigation (NEF-10). The work was performed at TSC by the Structures and Dynamics Division (DTS-76) and the Operator Performance and Safety Analysis Division (DTS-45).

This document was essentially completed in September, 1988. Since its detailed engineering analyses of the Audi complement the broader scope of the "Examination of Sudden Acceleration" study, TSC chose to publish the two reports together, with the Audi report as an appendix to the general report. The findings described in Chapter 7 and the summary of this appendix do not fully reflect the understandings of the significance of pedal design gained during the final quarter of 1988. The reader is referred to the general report for the more complete discussion of these matters.

TABLE OF CONTENTS

<u>Section</u>	<u>Page</u>
PREFACE	iii
1. INTRODUCTION AND SUMMARY	1-1
1.1 Background	1-1
1.2 Organization of TSC Study	1-1
1.3 Methodology	1-2
1.3.1 Potential Failure Modes – Power Train System	1-4
1.3.2 Potential Failure Modes – Braking System	1-5
1.3.3 Potential Failure Modes – Pedal Misapplication	1-6
1.4 Summary of Findings	1-6
2. IDENTIFICATION OF POTENTIAL MECHANICAL FAILURES FOR SUDDEN ACCELERATION INCIDENTS	2-1
2.1 Background	2-1
2.2 Closed Throttle Plate	2-1
2.2.1 Idle-Stabilization System	2-1
2.2.2 Ignition System	2-1
2.2.3 Fuel-Injection System	2-9
2.2.4 Exhaust Gas Recirculation Valve	2-9
2.2.5 Positive Crankcase Ventilation System	2-9
2.2.6 Vacuum System	2-12
2.3 Moving Throttle Plate	2-12
2.3.1 Linkage	2-12
2.3.2 Cruise Control	2-12
2.3.3 Transmission	2-12
2.4 Brake System	2-12
3. IDLE-STABILIZATION SYSTEM	3-1
3.1 Introduction	3-1
3.2 System Description	3-1
3.3 Vehicle Performance with Idle-Stabilizer Valve Fully Open	3-2
3.4 Control Unit and Sensors	3-8
3.4.1 Failure Analysis	3-8
3.5 Idle-Stabilizer Valve	3-15
4. CRUISE CONTROL SYSTEM	4-1
4.1 Introduction	4-1

4.2	Pneumatic System	4-1
4.3	Control Unit and Sensors	4-1
4.4	Possible Modes of Malfunction	4-5/4-6
4.5	Cruise Control Bench Test	4-5/4-6
5.	TRANSMISSION	5-1
5.1	Introduction	5-1
5.2	Engine/Transmission Linkage Description	5-1
5.3	Automatic Transmission	5-6
5.4	Description of Kickdown Valve Circuit	5-6
5.4.1	Kickdown Valve Operation and Failure Modes	5-9
5.4.2	Kickdown Valve Operation	5-9
5.4.3	Failure Modes	5-14
5.4.4	Stuck Valve	5-14
5.4.5	Inappropriate Pressure Applied to Kickdown Valve	5-14
5.5	Conclusions	5-16
6.	BRAKE SYSTEM	6-1
6.1	Introduction	6-1
6.2	System Description and Characteristics	6-1
6.3	Possible Malfunctions	6-4
6.4	Hydraulic Assist Malfunction and Recovery	6-4
6.5	Effects of a Driver Outracing the Hydraulic Pump	6-4
7.	DIMENSIONS, SPECIFICATIONS, AND FORCES RELATIVE TO THE AUDI DRIVING ENVIRONMENT	7-1
7.1	Objective and Approach	7-1
7.2	The Audi Driving Environment	7-1
7.3	Driver Factors	7-18
7.3.1	Age and Sex	7-19
7.3.2	Height	7-22
7.3.3	Experience	7-28
8.	RECOMMENDATIONS AND CONCLUSIONS	8-1
8.1	Power Train	8-1
8.1.1	Throttle Control System	8-1
8.1.2	Idle-Stabilizer System	8-1
8.2	Braking System	8-2
8.2.1	Complete Brake Failure	8-2
8.2.2	Temporary Failure of the Hydraulic Power-Brake Assist	8-2

8.3	Driver Factors	8-2
8.3.1	Driving Environment	8-3
8.3.2	Driver Population	8-3
8.3.3	Type of Driving	8-3
8.3.4	Experience of the Audi 5000 Driver	8-3
8.4	Summary	8-3
8.5	Additional Research	8-4
APPENDIX A -	IDLE-STABILIZER VALVE	A-1
APPENDIX B -	AUDI TEST DATA	B-1
APPENDIX C -	BRAKE SYSTEM	C-1
APPENDIX D -	ENGINE SURGE RESULTS OF A TEST VEHICLE	D-1
APPENDIX E -	DRIVER COMPARTMENT MEASUREMENTS: 1975-1981 DOMESTIC VEHICLES	E-1
APPENDIX F -	DRIVER COMPARTMENT MEASUREMENTS: 1984-1985 VEHICLES	F-1
REFERENCES	R-1

LIST OF FIGURES

<u>Figure</u>		<u>Page</u>
1-1	SUDDEN ACCELERATION INCIDENT SCENARIO	1-3
2-1	FAULT TREE ANALYSIS	2-2
2-2	SPARK TIMING CORRELATION FOR ALL SPEEDS AND LOADS	2-8
2-3	FUEL SYSTEM DIAGRAM FOR THE AUDI FIVE-CYLINDER ENGINE	2-10
2-4	PRODUCT F_n FOR FUEL-AIR CYCLES	2-11
3-1	FAULT TREE ANALYSIS: IDLE BYPASS SYSTEM	3-1
3-2	IDLE-STABILIZER VALVE LOCATION AND CONTROLS	3-2
3-3	ENGINE RPM VERSUS THROTTLE ANGLE IN REVERSE GEAR WITH BRAKES APPLIED	3-4
3-4	VEHICLE ACCELERATION VERSUS VELOCITY FOR A 1986 AUDI 5000S IN REVERSE GEAR WITH A 20° THROTTLE ANGLE	3-5
3-5	VEHICLE VELOCITY VERSUS DISTANCE FOR A 1986 AUDI 5000S IN REVERSE GEAR WITH A 20° THROTTLE ANGLE	3-6
3-6	VEHICLE VELOCITY VERSUS TIME FOR A 1986 AUDI 5000S IN REVERSE GEAR WITH A 20° THROTTLE ANGLE	3-7
3-7	WIRING DIAGRAM FOR THE IDLE-STABILIZATION CONTROL SYSTEM	3-9
3-8	LINEAR-ACTUATED IDLE-STABILIZATION VALVE	3-10

LIST OF FIGURES (continued)

<u>Figure</u>		<u>Page</u>
3-9	BLOCK DIAGRAM OF THE IDLE-STABILIZATION CONTROL VALVE	3-11
3-10	CIRCUIT BOARDS COMPRISING THE ELECTRONIC CONTROL UNIT (ECU)	3-12
3-11	ECU OUTPUT STAGE, 'J' VERSION	3-14
3-12	ORIENTATION OF VALVE COMPONENTS AND SIGN CONVENTIONS UNDER NORMAL OPERATION	3-16
3-13	TORQUE ON ARMATURE VERSUS VALVE OPENING ANGLE FOR THE COMMAND TO FULLY CLOSE WITH SPRING BROKEN	3-17
3-14	OPENING ANGLE OF VALVE AS A FUNCTION OF PERCENT DUTY CYCLE ON WINDING 1 DURING NORMAL AND BROKEN SPRING OPERATION	3-18
4-1	FAULT TREE ANALYSIS: CRUISE CONTROL	4-2
4-2	CRUISE CONTROL PNEUMATICS SYSTEM	4-3
4-3	CRUISE CONTROL COMPUTER CONTROL SYSTEM	4-4
5-1	FAULT TREE ANALYSIS: TRANSMISSION	5-2
5-2	SCHEMATIC OF THROTTLE LINKAGE AND TRANSMISSION GEARSHIFT LINKAGE	5-3
5-3	SELECTOR LEVER, SELECTOR SHAFT, OPERATING LEVER	5-4
5-4	OPERATING LEVER FOR KICKDOWN VALVE	5-5
5-5	TYPICAL AUDI 5000 VALVE BODY	5-7
5-6	1982 MODEL TRANSMISSION KICKDOWN VALVE CIRCUIT	5-8
5-7	SIMPLIFIED SCHEMATIC OF THE 1974-82 KICKDOWN VALVE CIRCUIT	5-10
5-8	DETAILED SCHEMATIC FLUID PATH FOR THE 1982 TRANSMISSION	5-11
5-9	KICKDOWN VALVE SCHEMATIC UNDER IDLE AND FULL THROTTLE POSITION	5-12
5-10	FREE BODY DIAGRAM AND KICKDOWN VALVE DIMENSIONS FOR A 1982 TRANSMISSION	5-13
5-11	KICKDOWN VALVE DEPRESSION/PRESSURE IN DRIVE AND REVERSE	5-15
6-1	VEHICLE DECELERATION VERSUS PEDAL FORCE	6-2
6-2	LOADING TIME FOR BRAKE ACCUMULATOR	6-3
7-1	T TABLE FOR AUDI	7-4
7-2	T TABLE FOR CADILLAC	7-5
7-3	5TH PERCENTILE FEMALE (59.5 IN) IN AUDI DRIVER'S SEAT	7-8
7-4	50TH PERCENTILE MALE (68.8 IN) IN AUDI DRIVER'S SEAT	7-9
7-5	95TH PERCENTILE MALE (73.2 IN) IN AUDI DRIVER'S SEAT	7-10
7-6	T VALUES FOR 1973-81 ODI DATA COMPARED TO 1978-86 AUDI 5000	7-12

LIST OF FIGURES (continued)

<u>Figure</u>		<u>Page</u>
7-7	T VALUES FOR 1982-86 TSC DATA COMPARED TO 1982-86 AUDI 5000	7-13
7-8	T VALUES FOR 1983-87 ODI DATA COMPARED TO 1985-86 AUDI 5000	7-14
7-9	ACCIDENT RATE AS A FUNCTION OF AGE AND SEX	7-23
7-10	NORMAL PROBABILITY PLOT OF MALE AUDI DRIVERS	7-26
7-11	NORMAL PROBABILITY PLOT OF FEMALE AUDI DRIVERS	7-27
7-12	CUMULATIVE ACCIDENT PERCENTAGE AS IT RELATES TO DRIVER EXPERTISE	7-29
7-13	AUDI INCIDENTS AS A FUNCTION OF MILEAGE	7-30
7-14	ACCIDENTS AS A FUNCTION OF MILEAGE	7-31
A-1	IDLE-STABILIZER VALVE SCHEMATIC AND DUTY CYCLE	A-2
A-2	ARMATURE FIELD WINDING CHARACTERISTICS MEASURED AND ESTIMATED	A-3
A-3	OPENING ANGLE OF VALVE AS A FUNCTION OF PERCENT DUTY CYCLE ON WINDING I DURING NORMAL OPERATION	A-5
A-4	ORIENTATION OF VALVE COMPONENTS AND SIGN CONVENTIONS	A-6
A-5	IDLE-STABILIZER VALVE UNDER NORMAL OPERATION	A-7
A-6	TORQUE ON ARMATURE VERSUS VALVE OPENING ANGLE FOR THE COMMAND TO FULLY OPEN	A-8
A-7	TORQUE ON ARMATURE VERSUS VALVE OPENING ANGLE FOR THE COMMAND TO FULLY CLOSE	A-9
A-8	IDLE-STABILIZER VALVE JUST BEFORE THE OVERRUN OPEN POSITION OCCURS	A-11
A-9	IDLE-STABILIZER VALVE UNDER OVERRUN OPEN OPERATION	A-12
A-10	IDLE-STABILIZER VALVE UNDER OVERRUN CLOSED OPERATION	A-13
A-11	SIMPLE SPRING MASS SYSTEM	A-14
A-12	OPENING ANGLE OF VALVE AS A FUNCTION OF PERCENT DUTY CYCLE ON WINDING I DURING NORMAL AND BROKEN SPRING OPERATION	A-15
A-13	TORQUE ON ARMATURE VERSUS VALVE OPENING ANGLE FOR THE COMMAND TO FULLY OPEN WITH SPRING BROKEN	A-16
A-14	TORQUE ON ARMATURE VERSUS VALVE OPENING ANGLE FOR THE COMMAND TO FULLY CLOSE WITH SPRING BROKEN	A-17
B-1	1986 AUDI 5000, REVERSE GEAR ACCELERATION (G) AT DIFFERENT THROTTLE ANGLES	B-2
B-2	1986 AUDI 5000, REVERSE GEAR VELOCITY (MPH)/TIME	B-3
B-3	1986 AUDI 5000, REVERSE GEAR VELOCITY (MPH)/DISPLACEMENT	B-4

LIST OF FIGURES (continued)

<u>Figure</u>		<u>Page</u>
B-4	NET ENGINE TORQUE (WARM)	B-5
B-5	TRANSMISSION TORQUE RATIO	B-6
B-6	TRANSMISSION EFFICIENCY	B-7
B-7	RATIO OF ANGULAR VELOCITY, AUDI 5000S, REVERSE GEAR	B-8
B-8	VEHICLE ACCELERATION VERSUS VELOCITY, 1986 AUDI 5000S, REVERSE GEAR, IDLE-STABILIZER VALVE FULLY OPEN	B-9
B-9	VEHICLE VELOCITY VERSUS DISPLACEMENT, 1986 AUDI 5000S, REVERSE GEAR, IDLE-STABILIZER VALVE FULLY OPEN	B-10
B-10	VEHICLE VELOCITY VERSUS TIME, 1986 AUDI 5000S, REVERSE GEAR, IDLE-STABILIZER VALVE FULLY OPEN	B-11
B-11	VEHICLE ACCELERATION VERSUS VELOCITY, 1986 AUDI 5000 CS TURBO, REVERSE GEAR, IDLE-STABILIZER VALVE FULLY OPEN	B-12
B-12	VEHICLE VELOCITY VERSUS DISPLACEMENT, 1986 AUDI 5000 CS TURBO, REVERSE GEAR, IDLE-STABILIZER VALVE FULLY OPEN	B-13
B-13	VEHICLE VELOCITY VERSUS TIME, 1986 AUDI 5000 CS TURBO, REVERSE GEAR, IDLE-STABILIZER VALVE FULLY OPEN	B-14
B-14	VEHICLE ACCELERATION VERSUS VELOCITY, 1984 AUDI 5000S, REVERSE GEAR, IDLE-STABILIZER VALVE FULLY OPEN	B-15
B-15	VEHICLE VELOCITY VERSUS DISPLACEMENT, 1984 AUDI 5000S, REVERSE GEAR, IDLE-STABILIZER VALVE FULLY OPEN	B-16
B-16	VEHICLE VELOCITY VERSUS TIME, 1984 AUDI 5000S, REVERSE GEAR, IDLE-STABILIZER VALVE FULLY OPEN	B-17
C-1	BRAKING FORCE REQUIREMENTS	C-2
C-2	SCHEMATIC OF HYDRAULIC POWER-ASSIST BRAKING SYSTEM	C-3
C-3	ACCUMULATOR MODEL	C-4
C-4	BLEED-DOWN CURVE	C-6
C-5	LOADING TIME FOR BRAKE ACCUMULATOR	C-8
C-6	HYDRAULIC BRAKE-ASSIST SERVO IN RELAXED POSITION	C-9
C-7	SELECTED DIMENSIONS OF THE PISTON AND SPOOL VALVE	C-10
C-8	SPOOL VALVE DISPLACEMENT	C-11
C-9	SPOOL VALVE DURING BRAKE RELEASE	C-12
C-10	CLOSED HIGH-PRESSURE PORT	C-13
C-11	BOOST SERVO COMPONENTS IN EQUILIBRIUM POSITION	C-13
C-12	SPOOL VALVE, RELAXED POSITION (FOOT OFF PEDAL)	C-14
C-13	DECELERATION CAPABILITY AS A FUNCTION OF PEDAL FORCE AND ACCUMULATOR PRESSURE	C-16

LIST OF FIGURES (continued)

<u>Figure</u>		<u>Page</u>
C-14	SERVO BOOSTER-MASTER CYLINDER PISTONS	C-16
C-15	PEDAL FORCE VERSUS PEDAL TRAVEL: HYDRAULIC BOOSTER	C-18
D-1	SAMPLE AND RECORDING SYSTEM	D-3

LIST OF TABLES

<u>Table</u>		<u>Page</u>
3-1	TEST RESULTS	3-3
7-1	COMPARISON OF GM FLEET AND SELECTED AUDI AND CADILLAC DIMENSIONS	7-3
7-2	COMPARISON OF OTHER INTERIOR DIMENSIONAL DATABASES TO THE AUDI	7-7
7-3	PEDAL DIMENSIONS AND DRIVER'S LATERAL PLACEMENT (mm)	7-11
7-4	AVERAGE PEDAL DIMENSIONS (mm) COMPARED TO AUDI 5000 AND SELECTED CADILLACS	7-15
7-5	FLOOR PEDAL DIMENSIONS	7-17
7-6	AGE AND SEX OF INCIDENT- AND ACCIDENT-INVOLVED DRIVERS	7-20
7-7	COMPARISON OF AUDI AND CADILLAC INCIDENTS	7-21
7-8	DISTRIBUTION OF PERSON TRIPS BY PURPOSE, AGE, AND SEX (1983 MALES)	7-24
7-9	DISTRIBUTION OF PERSON TRIPS BY PURPOSE, AGE, AND SEX (1983 FEMALES)	7-24
7-10	DISTRIBUTION OF HEIGHTS FOR MALE AND FEMALE DRIVERS INVOLVED IN SUDDEN ACCELERATION INCIDENTS AS COMPARED TO THE NATIONAL POPULATION	7-25
C-1	MAXIMUM BOOST-ASSISTED BRAKE PRESSURE	C-17
D-1	ENGINE SURGE SUMMARY	D-4
D-2	SUMMARY OF INCIDENTS	D-5
D-3	COMPLETE RECORD BEFORE AND AFTER INCIDENT	D-6

1. INTRODUCTION AND SUMMARY

1.1 BACKGROUND

The National Highway Traffic Safety Administration's (NHTSA) Office of Defects Investigation (ODI) is currently investigating owner complaints about the Audi 5000. These complaints allege that the vehicle produces sudden, uncontrollable accelerations known as "sudden acceleration incidents" (SAIs). For SAIs resulting in accidents, driver reports provided to ODI typically indicate that while the vehicle was at rest the driver shifted the transmission from park to reverse or drive, the vehicle suddenly accelerated, and the brakes could not bring the car under control. The incidents reported frequently occurred during the first year of ownership. After an incident, inspection of the vehicle by NHTSA usually revealed no failure or malfunction of any vehicle system.

Although reports of SAIs have been received for a variety of automobile makes and models, ODI has found that the Audi 5000 has been associated with the greatest rate of such complaints. According to ODI, for the 1978 to 1986 model years (as of October 18, 1988), drivers attributed 556 accidents per 100,000 Audi 5000 vehicles sold in the U.S. to sudden acceleration. The highest comparable rate for other makes and models was 28 per 100,000 vehicles.

Initial investigations by both the U.S. importer, Volkswagen of America (VWOA), and ODI could find no consistent mechanical failures that could cause this phenomena. VWOA has claimed that these incidents were the result of driver error, and that drivers reporting SAIs had inadvertently depressed the accelerator pedal instead of the brake pedal.

In the period 1982 to 1987, VWOA conducted four recall campaigns germane to SAI reports:

- In April 1982, a recall was conducted to modify the accelerator pedal to prevent interference with the floor mats.
- In September 1983, a plate was attached to the brake pedal to elevate it relative to the accelerator pedal.
- In July 1986, Audi began replacing some idle-stabilizer valves in conjunction with an unrelated recall.
- During September 1986, as part of a service action, Audi began installing automatic shift locks (ASL) in 1984-86 vehicles.
- In January 1987, a formal voluntary recall was initiated to install ASL in all model years, to check for idle speed problems, and to replace certain stabilizer valves
- In October 1987, VWOA announced a recall of the idle-stabilizer system for the 1984 and 1985 Audi 5000s. (VWOA contends that this recall is not related to SAI problems.)

As part of its continuing investigation, ODI requested that the U.S. Department of Transportation, Transportation Systems Center (TSC) perform an independent analysis of the Audi's electronic, electromechanical, and mechanical systems; driver compartment configuration (particularly the control dimensions and forces); and driver population characteristics to identify any possible associations between these factors and SAIs. This report details the results of TSC's analysis.

1.2 ORGANIZATION OF TSC STUDY

This study included: (1) an examination and fault tree (detailed failure mode) analysis of the vehicle's major mechanical, electronic, and electromechanical subsystems to determine the conditions under which these subsystems could be responsible for the incidents; (2) an analysis of the dimensions and design of the Audi driver compartment to determine if the features of

the compartment and driving controls might increase the probability of pedal misapplication resulting in an SAI; and (3) an analysis of the characteristics of Audi drivers to determine if they are more likely than the drivers of other vehicles to be involved in or exposed to situations where an SAI could occur.

Figure 1-1 depicts the potential causes and results of an SAI. As is indicated, the incident must be initiated by an increase in engine power. This increase may be caused either by a system malfunction (a failure in one or more of the engine systems listed in Figure 1-1), or by the driver inadvertently depressing the accelerator. In the former case, loss of vehicle control can occur if the brakes fail, or if the driver inadvertently depresses the accelerator rather than the brake pedal or otherwise fails to apply the brakes. If the initiating cause is pedal misapplication, loss of control can occur if the driver continues to depress the accelerator pedal, believing it to be the brake. This report summarizes the material gathered by TSC with regard to the features of the vehicle that could potentially lead to system malfunction and/or pedal misapplication.

An analysis of the Audi's power train (Section 2) indicated that the following systems are the most likely potential sources of a malfunction leading to the initiation of an SAI:

- the idle-stabilizer system
- the cruise control system
- the transmission linkage

Information on the design of these systems and the results of tests conducted are presented in Sections 3, 4, and 5.

In an SAI, failure to stop the vehicle must involve either a failure by the driver to apply the brakes or a malfunction of the braking system. The braking system is discussed in Section 6.

If the initiation of the incident and subsequent loss of control are not due to a vehicle system malfunction, they must then be due to pedal misapplication. The accuracy and timeliness with which the driver controls the vehicle are strongly influenced by both the design and dimensions of the operating controls and the driver's familiarity with the vehicle. Data comparing these aspects of the Audi 5000 with those of other cars in the U.S. fleet, as well as information on the anthropometry and demographic characteristics of Audi 5000 drivers, are presented in Section 7.

1.3 METHODOLOGY

In the study, TSC used the following logic:

- The SAI must be initiated by a significant increase in engine power. This can be caused either by a failure in one or more engine systems or by a pedal misapplication.
- If the initiating cause is a system malfunction, loss of vehicle control can occur through either brake failure or pedal misapplication.
- If the initiating cause is pedal misapplication, loss of control can occur if the driver is not aware of it and continues to depress the accelerator pedal.
- Driving a vehicle with an unfamiliar or unusual driving compartment configuration can increase the probability of pedal misapplication.
- If the cause of an SAI is an electromechanical or mechanical failure, physical evidence of such a failure should be detectable in a post-SAI examination of the vehicle.

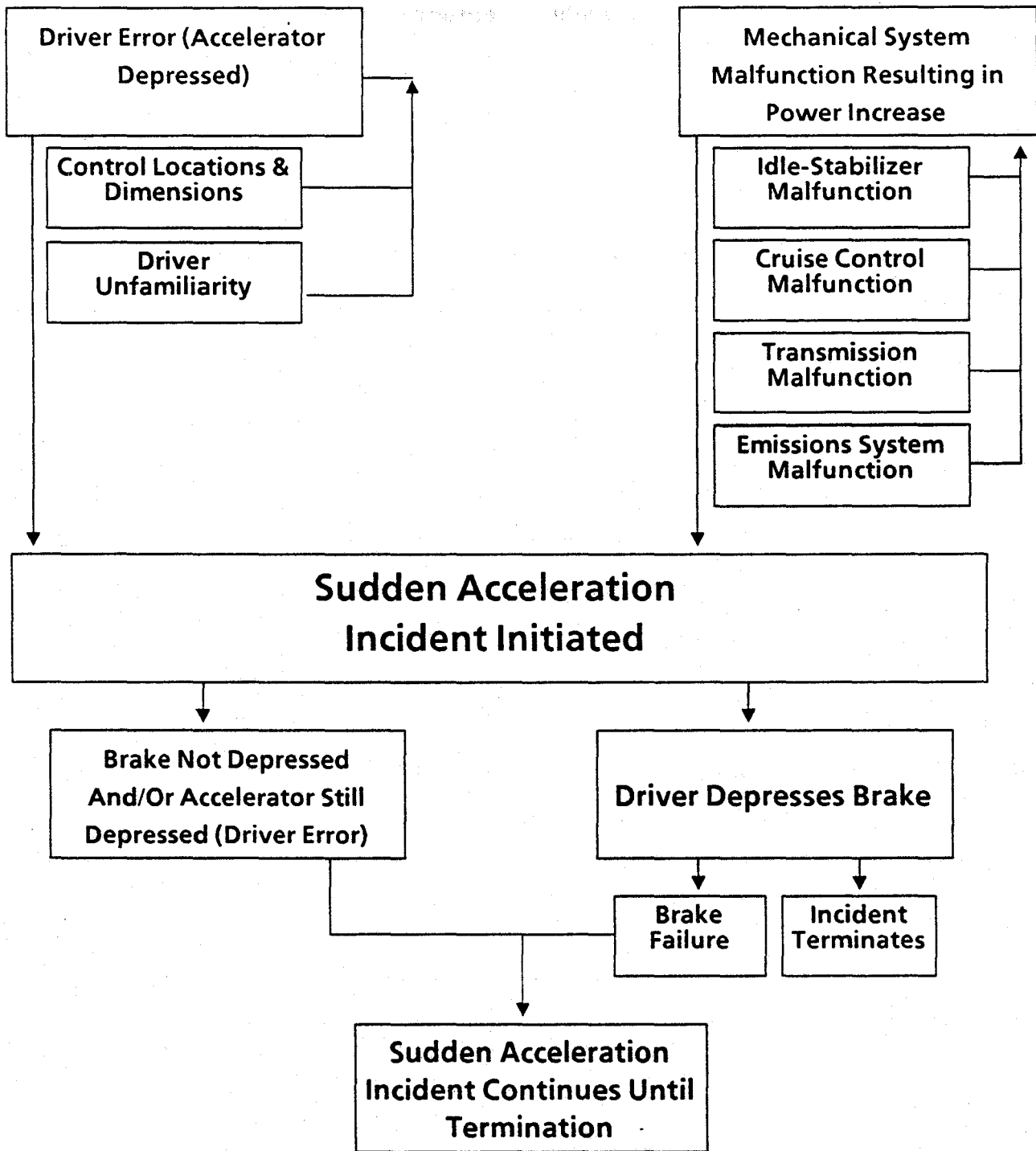

FIGURE 1-1. SUDDEN ACCELERATION INCIDENT SCENARIO

- If an intermittent electronic failure is the cause of the SAI, post-incident detection may be much more difficult but the failure mode should be reproducible either through in-vehicle or laboratory bench tests.

1.3.1 Potential Failure Modes - Power Train System

Significant increases in engine power (sufficient to produce an SAI) can be produced only if both air and fuel flows to the engine are increased while maintaining a fuel-air mixture which provides relatively complete fuel combustion. In the Audi 5000, when metered airflow increases, the fuel management system increases fuel flow, resulting in an immediate increase in engine power.

TSC's analysis indicated that in the case of the Audi 5000, this increase in engine power could be possible only through driver movement of the throttle mechanical movement of the throttle plate (caused by malfunction of the accelerator linkage or transmission "feedback" linkage to the accelerator linkage)

- malfunction of the cruise control
- malfunction of the idle-stabilizer system
- some other malfunction which increases airflow to the fuel management system, e.g., air leakage

Malfunctions of the engine ignition and timing system, emissions control system, and engine vacuum systems could not produce the power involved in an SAI.

Throttle System – After the accelerator pedal is depressed, the throttle linkage could conceivably "stick," causing the pedal to hold its position. This could be caused by binding in the system or some mechanical interference with the linkage or the pedal. The first SAI-related recall by VWOA involved installation of a shield on the accelerator pedal to prevent jamming against the floor mat. While accelerator pedal "sticking" has been reported to ODI by owners, these incidents do not fit the spontaneous acceleration scenario. However, they could fit the scenario if the pedal were stuck before the vehicle had been started.

Transmission Activation of Throttle – In the 1978 through 1983 Audi 5000, the transmission could conceivably activate the linkage and throttle plate in a shift from drive into neutral, reverse, or park. In these models, the throttle plate could be opened if an unbalanced pressure of at least 117 psi were applied to the kickdown valve. An SAI due to transmission activation of the throttle would require multiple failures, would be irreversible, and would be easily detected after the fact. No evidence of such failures was found in vehicles exhibiting SAIs by TSC or ODI investigators.

Cruise Control System – Multiple simultaneous failures in this system would be required to produce SAIs from a stopped or low-speed condition (the SAI reported by the great majority of involved drivers). Both a gear-selector safety switch (powered only in drive or second gear) and an operator's switch would have to be closed, and an electronic control unit (designed to function only above 30 mph) must fail to initiate an SAI. In addition to these failures, a simultaneous mechanical failure in the vacuum breaker attached to the brake pedal would be required to prevent the driver from defeating the cruise control by braking. No evidence of such failures was found in vehicles exhibiting SAIs by TSC or ODI investigators.

Self-activation of the cruise control's "resume" function at speeds above 30 mph with the cruise control switch on has been observed in one instance by TSC, and other drivers have reported such incidents to NHTSA and VWOA. Such incidents do not, however, resemble the typical SAI.

Idle-Stabilizer System - Audi 5000 (1984 and thereafter) incorporates an idle-stabilizer system which regulates engine speed in response to the demands of engine load. The system is composed of an electronic control unit and an electromechanical air valve. Two types of valves are used in the vehicles of interest: a rotary valve and a linear valve.

When the electronic control unit in this system malfunctions, excess current may flow through the idle-stabilizer valve, causing it to open fully and thereby producing an immediate increase in engine power. Tests reported by VWOA (October 1986) have indicated that the idle-stabilizer system alone can accelerate the Audi 5000 at an initial rate of 0.3 g, which is similar in magnitude to an emergency stop in a subway car. With the valve fully open, the vehicle can reach speeds of 20 to 25 mph in reverse or forward gears in approximately 10 seconds, and eventually reach speeds of 40 to 50 mph in forward gears.

Intermittent malfunctions of the electronic control unit were observed and recorded by TSC in this study and have been reported by Transport Canada (personal communication). Such failures, because of their intermittent nature, would most likely not be detected during normal Audi-specified testing of the unit, or in post-accident NHTSA investigations.

In the rotary-valve version of the idle stabilizer, problems with intermittent failures of the commutator contacts have been reported. Such defects may cause engine surging directly and may also cause oscillations leading to premature spring failure. Once the spring has broken, idle stabilization is apt to become more erratic.

1.3.2 Potential Failure Modes - Braking System

The reports of SAIs indicate that once the increase in engine power began, the driver could not stop the vehicle with the brakes, implying brake failure. TSC and NHTSA tests indicate that the Audi 5000 brakes, when operating properly at the low road speeds typical of the SAI, will hold or stop the car even under full throttle.

Temporary Failure of the Hydraulic Power-Brake Assist - The hydraulic power boost used in 1984 and later models hold sufficient pressurized fluid for 15 to 20 brake applications after engine shutdown. If the Audi engine speed is above 1000 RPM (as is characteristic of SAI reports), rapid pumping of the brake pedal cannot deplete the reservoir. Even with depletion of the reservoir the brakes still operate, but require four to five times the normal force from the driver to stop the car (not beyond the capability of the great majority of drivers). A malfunction resulting in failure of the hydraulic power-brake assist with the engine running would be detectable in post-SAI investigations. No evidence of such malfunctions was found in vehicles exhibiting SAIs by TSC or ODI investigators.

Complete Brake Failure - This can be caused only by loss of hydraulic fluid pressure from both sides of the dual hydraulic brake systems incorporated in all of the Audi 5000s with reported SAIs. Such complete, simultaneous failures are irreversible and would be easily detected after an incident. No evidence of such failures was found in vehicles exhibiting SAIs by TSC or ODI investigators.

1.3.3 Potential Failure Modes - Pedal Misapplication

VWOA has claimed that the SAIs reported for the Audi 5000 were a result of pedal misapplication. TSC analyzed the interior dimensions of the Audi 5000, the dimensions and actuation forces of its controls, and the characteristics of its driver population to identify factors which could induce pedal misapplication and cause or contribute to the disproportionate number of SAIs reported for the vehicle.

Driving Environment - TSC performed a statistical study comparing the Audi 5000's interior seating and pedal arrangements to hundreds of other vehicle models in the U.S. fleet for critical driver-related dimensions. The study revealed statistically significant differences for 20 dimensions. Among the dimensions which were significantly different were seat height; knee angle; lateral steering-wheel position; knee clearance; brake pedal force, size, height, and travel; and accelerator pedal size and height.

Prior research by TSC (Hoxie 1984) and NHTSA (Percl 1983) have revealed that driver unfamiliarity with a vehicle can markedly increase the likelihood of an accident.

From the statistical comparison of vehicle interior dimensions and the studies of driver familiarity, it can be conjectured that drivers who have extensive experience with other vehicles but are new to the Audi may make a disproportionate number of pedal misapplication early in their use of the vehicle.

TSC's analysis of NHTSA's National Accident Sampling System indicates that 34 percent of all drivers involved in accidents nationwide have less than 6 months of experience with the vehicle involved. By way of comparison for Audi SAIs, 44 percent of the drivers had less than 6 months' experience with the vehicle.

Driver/Driving Characteristics - A major source of statistical variation in automobile accident rates is the demographic characteristics of the driver. TSC found that middle-aged and older drivers involved in Audi 5000 SAIs were overrepresented when compared with drivers in all accidents nationwide. (This is especially true for middle-aged and older female drivers.) Such individuals are similarly overrepresented as owners and drivers of the Audi 5000.

In addition, the Nationwide Personal Transportation Study shows that female drivers take more trips which require frequent starts and stops, conditions which increase the opportunity for SAIs.

1.4 SUMMARY OF FINDINGS

Based on its analysis of the Audi 5000, its components, and NHTSA and VWOA data, TSC reached the following conclusions:

- The Audi 5000 has mechanical and electronic failure modes that could induce engine surging and produce unexpected increases in engine power. In particular, failures in the idle-stabilizer system used in 1984 to 1986 vehicles have been observed which produce surges typical of some SAIs and could potentially initiate such incidents. Because of their intermittent nature, these idle-stabilizer system failures would most likely not be detected during normal Audi-specified testing of the unit, or in post-accident NHTSA investigations.
- The complete brake failures reported in the Audi 5000 SAIs are very unlikely events which, had they occurred, would have been detectable after an incident or accident. Only one such incident is known to have occurred. In that instance, brake hoses were severed.

- The seating, pedal arrangements, and pedal forces of the Audi 5000 are significantly different from the standard domestic vehicles, increasing the likelihood of confusion of the brake and accelerator pedal for drivers new to the vehicle.
- The apparent overrepresentation in the Audi 5000 driver population of individuals whose driving patterns involve frequent "starts" may have increased the opportunity for SAIs.

In summation, TSC was not able to identify any combination of malfunctions in the Audi 5000 which would simultaneously produce sudden acceleration and brake failure without leaving readily obvious evidence. Failures in the idle-stabilizer system, and to a much lesser extent the cruise control system, were identified which are capable of initiating an SAI without leaving evidence detectable under normal test procedures.

Furthermore, failures in the braking system which would preclude the driver from stopping the car were not identified. TSC also determined that the dimensions of the Audi 5000 driver's compartment and the forces and dimensions of its controls are significantly different than other vehicles in the U.S. fleet, increasing the possibility of pedal misapplication in individuals unfamiliar with the vehicle. It can therefore be concluded that once unwanted acceleration has begun, pedal misapplication resulting from panic, confusion, or perhaps unfamiliarity with the Audi 5000 contributes to the severity of the incident.

2. IDENTIFICATION OF POTENTIAL MECHANICAL FAILURES FOR SUDDEN ACCELERATION INCIDENTS

2.1 BACKGROUND

The typical reported scenario for sudden acceleration is that the driver enters an already warmed-up car (i.e., engine at operating temperature), starts the car, and moves the shift lever into drive or reverse. The car then rapidly accelerates in the direction of the gear selected. Although the driver immediately applies the brake, the vehicle does not stop. The SAI is stopped when the ignition switch is turned off, the transmission is shifted to park or neutral, or the vehicle strikes an object. Inspection of the vehicle after the incident typically shows no mechanical malfunction. Usually the car has less than 10,000 miles on the odometer. An equal number of incidents occur in drive and reverse.

For sudden acceleration to occur, the engine of the vehicle must develop power. To study the possible mechanical causes of increased engine power, a fault tree analysis was performed (see Figure 2-1). The fault tree shows that for the engine to develop sufficient power, the flow of both air and fuel must increase. Fuel and airflow increases with an open throttle plate, an open idle-stabilizer valve, or a malfunction that allows an increased air and fuel mixture to enter the intake manifold. The systems capable of changing the engine performance by moving the throttle plate include the cruise control system, the transmission and kickdown valve, and the throttle linkage system. The systems capable of changing the engine performance with the throttle plate closed (idle position) include the ignition system, the fuel-injection system, the exhaust gas recirculation system, the positive crankcase ventilation system, and the idle-stabilization system. These systems and components are reviewed in the following sections. Particular emphasis is placed on identifying systems and components capable of malfunctioning in an intermittent or self-correcting manner.

2.2 CLOSED THROTTLE PLATE

2.2.1 Idle-Stabilization System

The idle-stabilization system adjusts the amount of metered air that bypasses the throttle plate at idle conditions. The valve operates continuously when the throttle plate is fully closed. It responds to different engine loading conditions to maintain a constant, preset idle speed. If this valve were to malfunction, the vehicle could accelerate in forward or reverse. TSC calculated that a fully open idle-stabilizer valve on a 1986 Audi 5000S produces an initial acceleration of 0.3 g and would reach a final speed of 33 mph in reverse gear or 40 to 45 mph in forward gear. This vehicle acceleration may alarm the driver. Since the idle-stabilization system has these capabilities, a detailed discussion of its operation and possible failure modes is presented in Section 3.

In Sections 2.2.2 through 2.2.6, changes in engine performance (brake torque) are estimated from test data on typical gasoline engines (Taylor 1966).

2.2.2 Ignition System

The ignition system, which is computer-controlled, supplies a 32,000 V spark to each cylinder at the proper time. A change in ignition system timing could increase the engine performance at idle. At idle, the timing of the spark is usually retarded 15 to 20° from the MBT (Maximum Torque) timing position. As shown in Figure 2-2, the brake mean effective pressure (ratio of brake torque to volumetric displacement) changes about 18 percent from the MBT timing position to the 20° retarded position. If the timing were changed to the MBT position from the 20° retarded position, the indicated

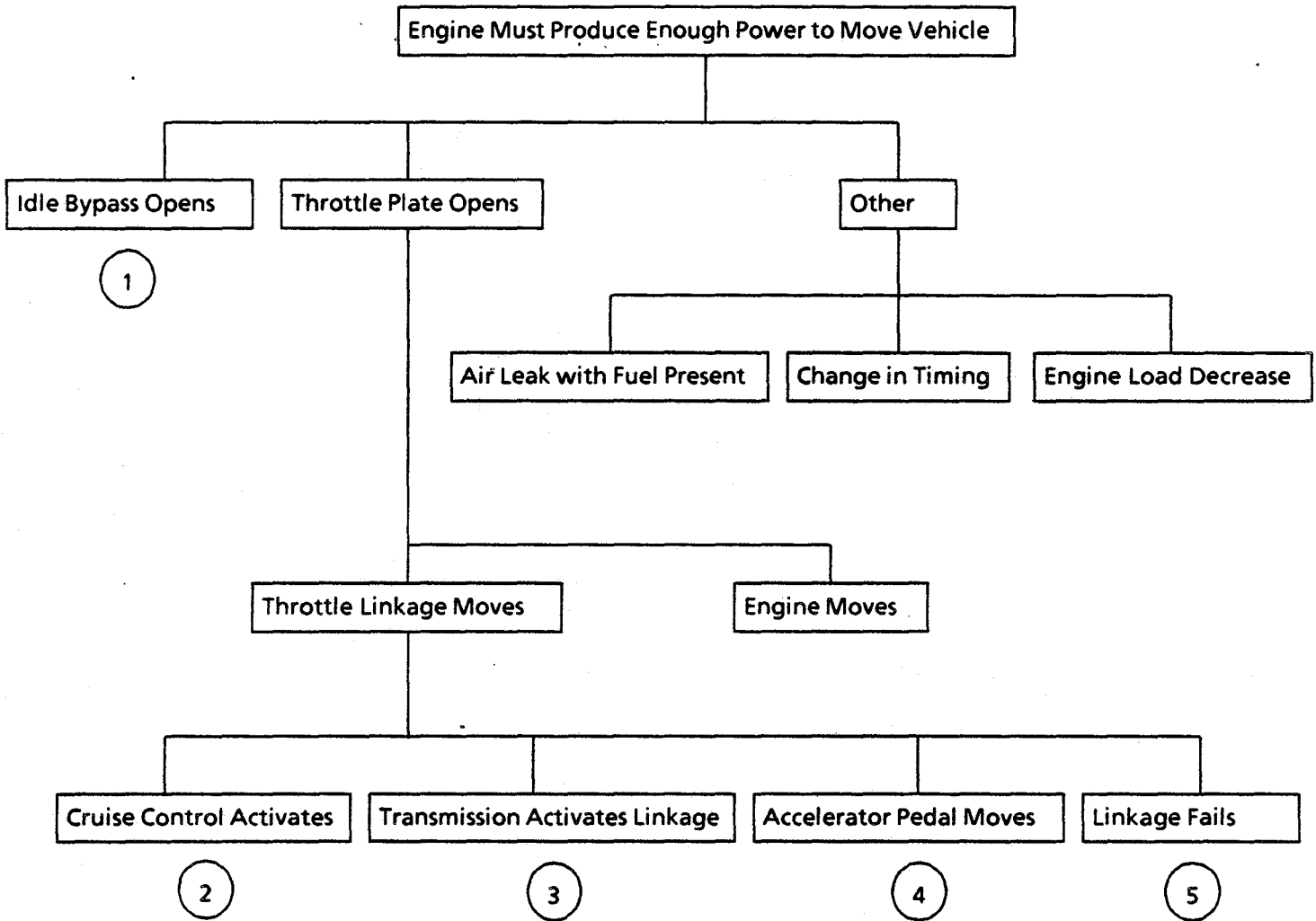

FIGURE 2-1. FAULT TREE ANALYSIS

Idle Bypass Opens

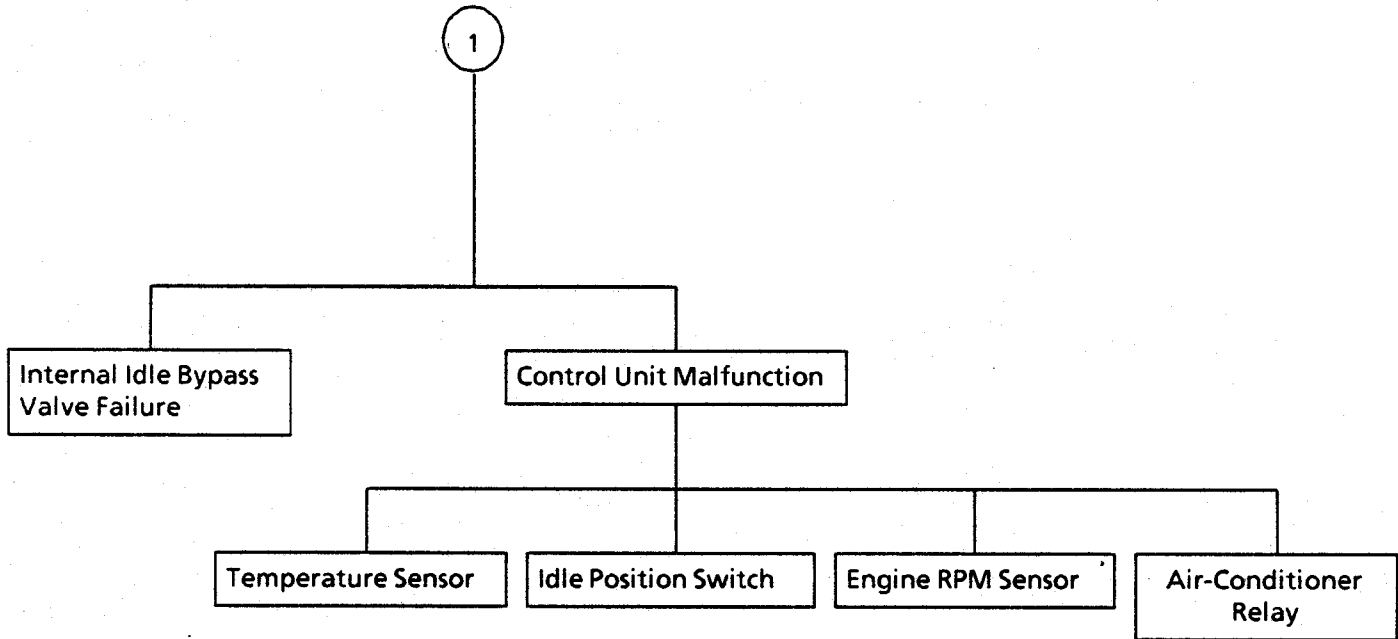

FIGURE 2-1. FAULT TREE ANALYSIS (continued)

Cruise Control Activates

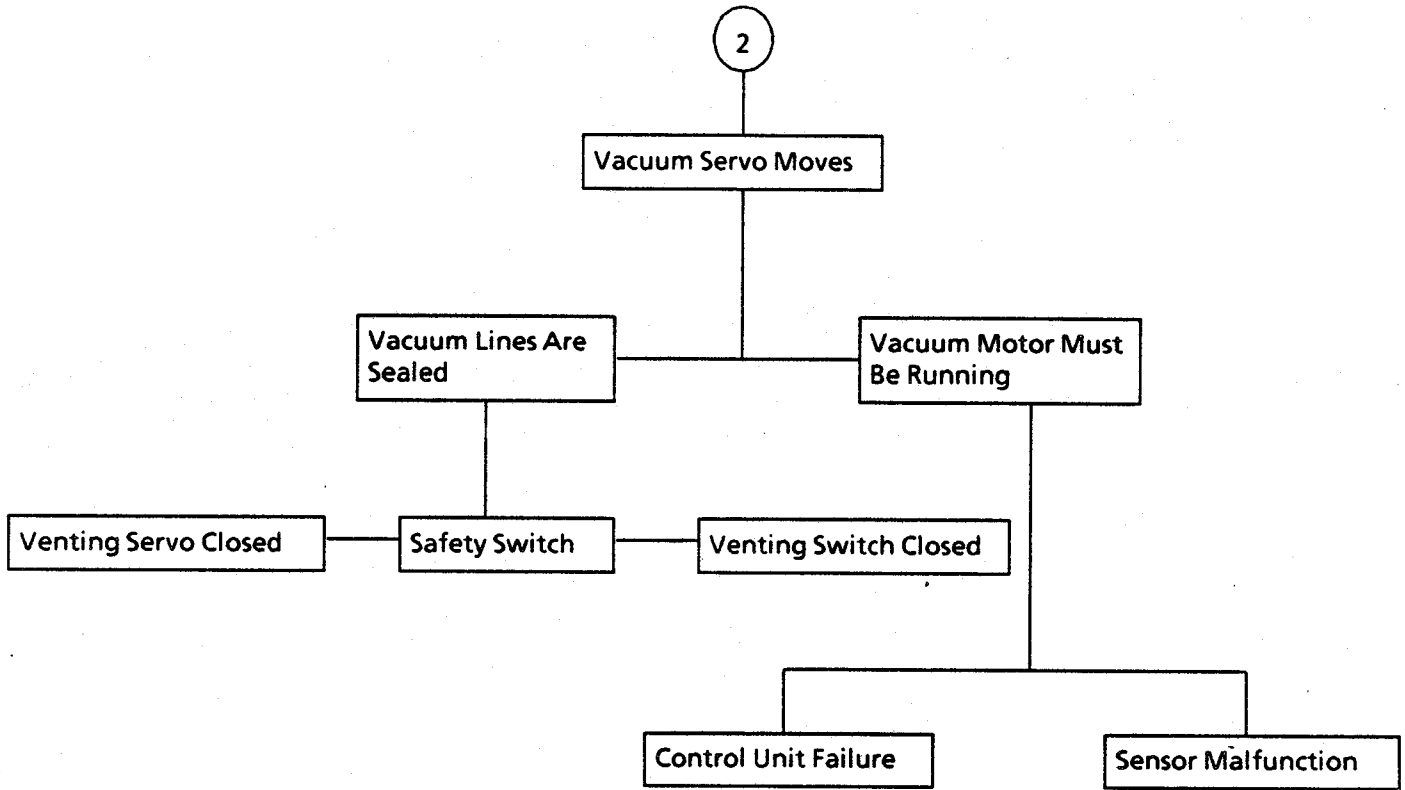
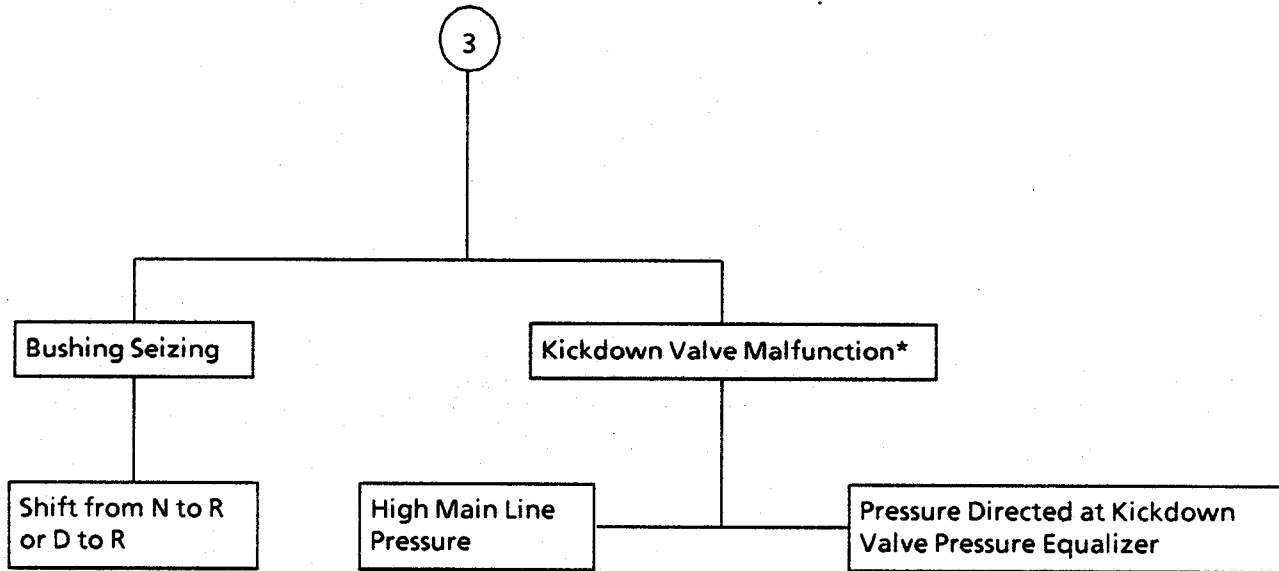

FIGURE 2-1. FAULT TREE ANALYSIS (continued)

Transmission Activates Linkage



*Does not apply to transmissions from 1984 to 1986

FIGURE 2-1. FAULT TREE ANALYSIS (continued)

Accelerator Pedal Moves

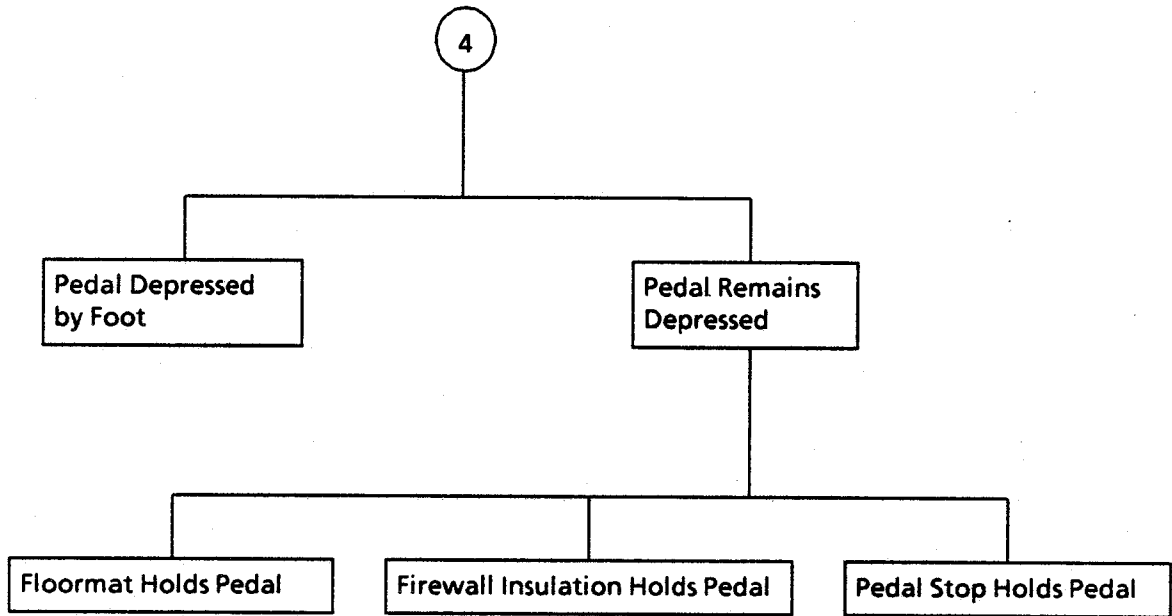

FIGURE 2-1. FAULT TREE ANALYSIS (continued)

Throttle Linkage Failure

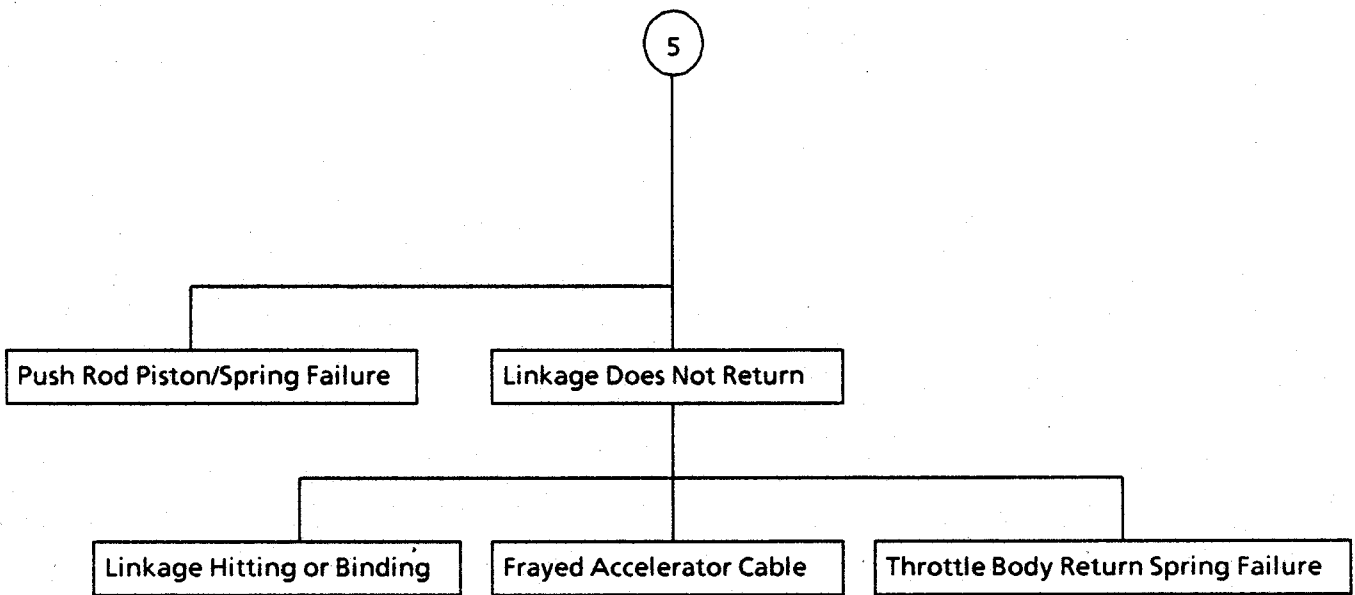
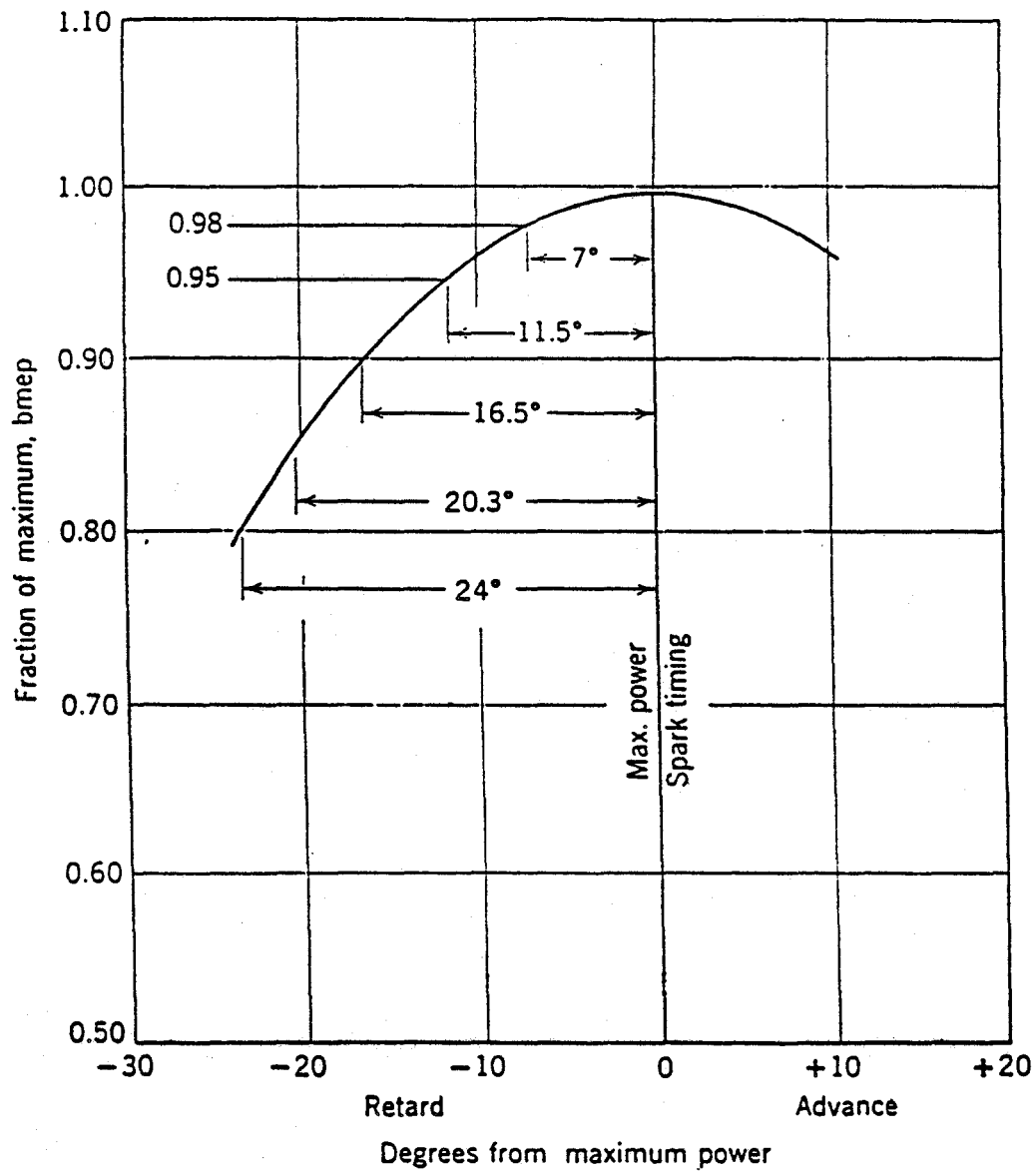

FIGURE 2-1. FAULT TREE ANALYSIS (continued)



SOURCE: Taylor 1966, 443.

FIGURE 2-2. SPARK TIMING CORRELATION FOR ALL SPEEDS AND LOADS

torque at idle could increase up to 18 percent. Based on this, TSC estimates the change in brake torque would have an upper bound of 3.2 lb-ft for the Audi five-cylinder engine. The resultant change in the vehicle acceleration is not significant enough to cause an SAI.

2.2.3 Fuel-Injection System

The fuel-injection system used in the Audi 5000 from 1978 through 1986 model years is called the continuous-injection system (CIS). This system continuously injects fuel to all cylinders in quantities proportional to the amount of air drawn in by the engine. There are two methods for the fuel-injection system to deliver the appropriate fuel-air mixture to the engine. The primary method is to directly measure the amount of air entering the intake manifold with an airflow sensor plate mounted before the throttle plate (see Figure 2-3). The secondary method is through control based on the oxygen level in the exhaust gases. An oxygen sensor measures the amount of oxygen in the exhaust gases while the fuel-injection computer control unit monitors the sensor to determine the amount of additional fuel to allow into the fuel injectors. This part of the fuel-injection system does the "fine" fuel metering while the airflow sensor does the "coarse" fuel metering. The flow of air into the engine is controlled by the throttle plate position, idle stabilizer, and the idle air bleed. These air regulators allow "metered" air (air that is measured by the sensor plate) into the intake manifold. At idle, the fuel-air mixture is maintained around stoichiometry (fuel-air equivalence ratio or $Fr = 1.0$) as shown in Figure 2-4. If the air regulators are properly operating and a fuel system malfunction caused the fuel-air mixture to become richer ($Fr > 1.0$), the maximum torque increase would be about 5 percent of idle torque. If the fuel-air equivalence ratio increased to greater than 1.2, engine performance would decrease, and eventually the engine would stall. If the fuel-air mixture was leaned out ($Fr < 1.0$), the engine performance would also decrease until the engine stalled. The maximum change in torque is on the order of 1 to 2 lb-ft, which is not significant enough to cause sudden acceleration.

2.2.4 Exhaust Gas Recirculation Valve

The exhaust gas recirculation (EGR) valve is generally mounted on vehicles that do not use the oxygen sensor and three-way catalyst, i.e., vehicles equipped to be used in Canada or pre-1984 Audis. The EGR valve is mounted between the exhaust manifold and the intake manifold. This valve allows exhaust gases into the intake manifold to cool combustion temperatures and reduce exhaust emissions. For the valve to operate, the engine must be fully warmed up and the throttle plate must be in a part-throttle position. An open EGR valve with the throttle plate fully closed (at idle) could only cause a decrease in engine performance. The inert exhaust gases entering the intake charge decrease the amount of oxygen present to burn the fuel. As a result, the flame speeds in the combustion chamber would be low and the overall combustion would be poor. The result of poor combustion is a very rough idle and possible engine stalling. A failed EGR system could not cause sudden acceleration.

2.2.5 Positive Crankcase Ventilation System

The positive crankcase ventilation system for the Audi 5000 consists of a restrictor mounted in a hose from the crankcase of the engine to the air intake. This allows exhaust gases and any unburned fuel-air mixture that has escaped past the cylinders to reenter the air intake charge. If the positive crankcase ventilation system failed by eliminating the restrictor, the effect would be the same as leaning out the mixture; the engine would decrease in performance and eventually stall. If the restrictor became clogged, the fuel-air mixture could become richer ($Fr > 1.0$). The maximum increase in idle torque would be on the order of 5 percent (less than 0.1 g initial vehicle acceleration), which is not significant enough to cause sudden acceleration.

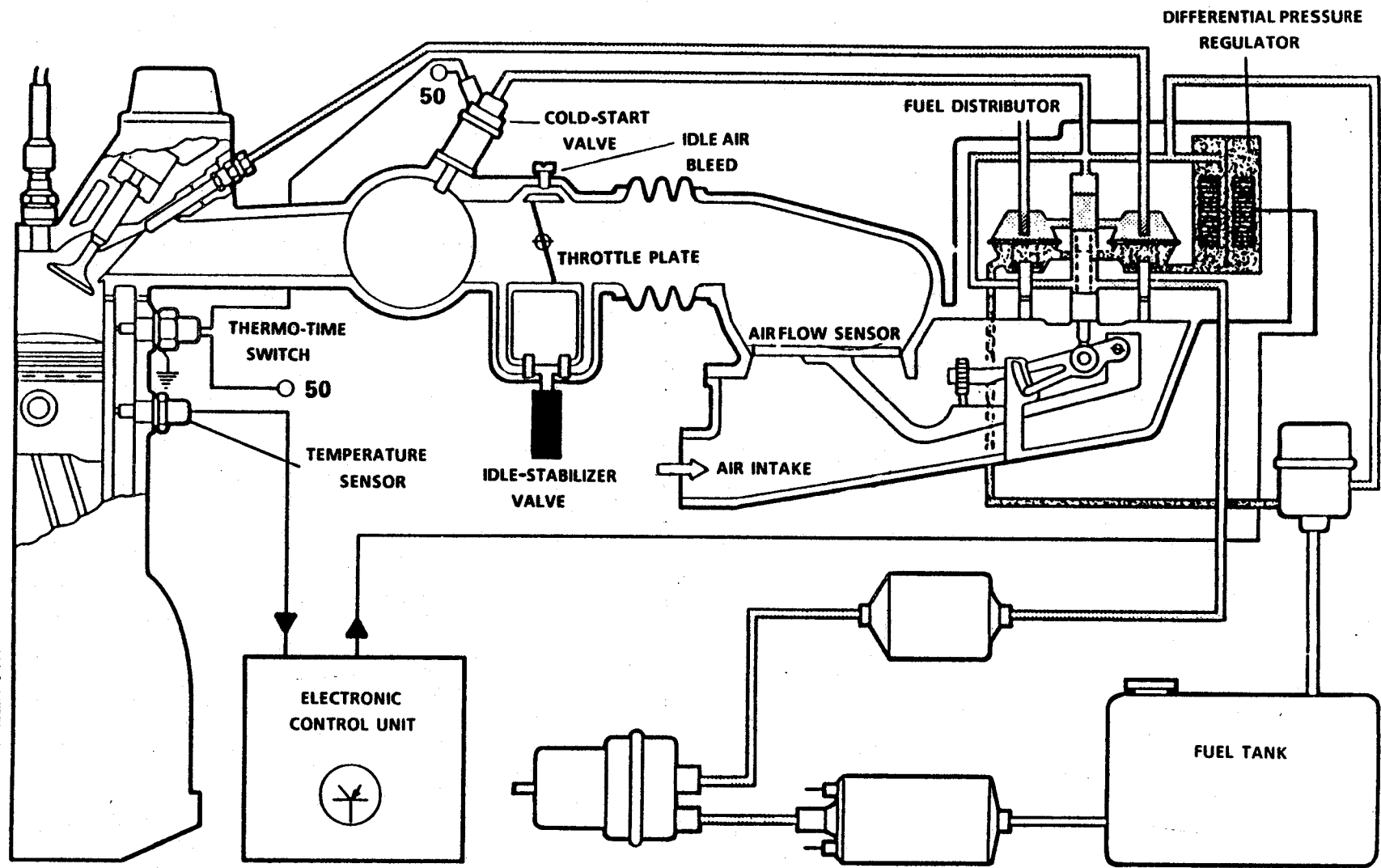

SOURCE: CIS-Electronic Fuel Injection Training Manual 1986, 18.

FIGURE 2-3. FUEL SYSTEM DIAGRAM FOR THE AUDI FIVE-CYLINDER ENGINE

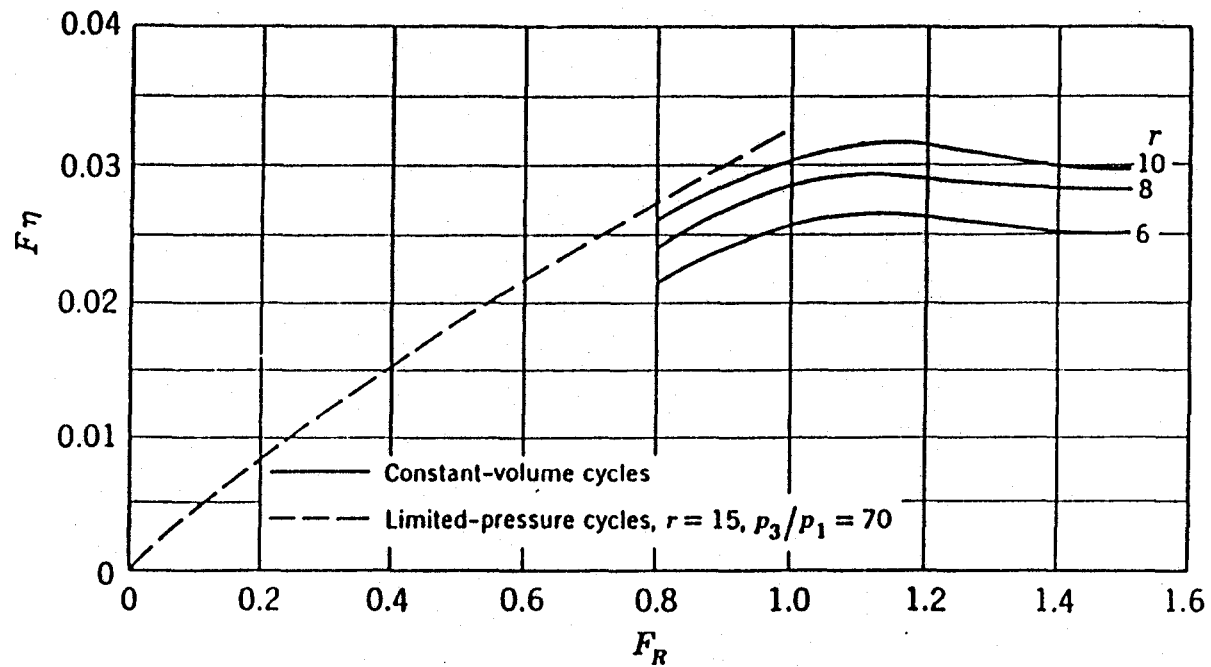

F_R \equiv EQUIVALENCE RATIO: $F_R = 1.0$ STOICHIOMETRY
 $F_R < 1.0$ LEAN
 $F_R > 1.0$ RICH
 $F_\eta \equiv$ (FUEL-AIR RATIO) \times (INDICATED THERMAL EFFICIENCY)

SOURCE: Taylor 1966, 437.

FIGURE 2-4. PRODUCT F_η FOR FUEL-AIR CYCLES

2.2.6 Vacuum System

When the engine is under idle conditions, the vacuum in the intake manifold is at its highest level. At idle, a leaking gasket or a broken vacuum line would allow unmetered air to enter the intake manifold. Since the air is not measured by the airflow sensor, the fuel-air mixture would lean out ($F_r < 1.0$). The oxygen sensor in the exhaust manifold would sense this change in the fuel-air mixture. The fuel-injection control unit adjusts the differential pressure valve which readjusts the fuel-air mixture by providing more fuel. A small air leak could produce a limited power increase, the magnitude of which cannot be precisely determined because the adjusting limits of the differential pressure valve are not known. If the air leak were large enough, the control unit could not adjust the fuel to overcome the excess air. Engine performance would then decrease and the engine would eventually stall. In any event, significant air leaks would remain detectable and would not correct themselves.

2.3 MOVING THROTTLE PLATE

2.3.1 Linkage

Throttle plate movement allows air measured by the sensor into the intake manifold. The fuel mixture for this air would be adjusted to the proper ratio. The performance of the engine would then be limited only by the amount of air that was allowed into the engine (that is, the throttle plate position). There are three methods for the throttle plate to be opened. The first is by activation of the cruise control (see Section 4). The second method is by linkage attached to the transmission's throttle valve. This method is only applicable to pre-1984 Audi 5000s, since the linkage connection was then changed from a mechanical link to a butted joint. The butted joint cannot transmit a tension force from the transmission kickdown valve to the throttle linkage (see Section 5). The throttle plate can also be opened by the operator depressing the accelerator pedal. If the accelerator pedal were depressed and remained depressed, the fault could be due to broken linkage, sticking pivots, faulty return springs, or some other mechanical interference such as floor carpets.

2.3.2 Cruise Control

The cruise control system has a vacuum servo that is directly connected to the throttle plate. If a vacuum were applied to this servo and maintained, the throttle plate could be moved to a fully open position. The cruise control system has many safeguards to prevent this from happening. For the system to apply a vacuum to the servo, two simultaneous component failures must occur. Refer to Section 4 for a detailed analysis of possible failure modes.

2.3.3 Transmission

Because there is a direct link between the engine's throttle valve and the transmission's kickdown valve which could possibly open the throttle, TSC studied the linkage as a possible factor in SAIs. The transmission can only affect operation in this way in 1978 through 1983 Audis, as later models have been reconfigured. Further, should a failure occur, it would not be reversible and would be found in post-incident investigations. Section 5 discusses the linkage between the engine and the kickdown valve of the transmissions, as well as automatic transmission operation, kickdown valve operation, and potential failure modes.

2.4 BRAKE SYSTEM

Once sudden acceleration has occurred, the brakes should be able to stop the car. A typical driver complaint is that the brake pedal was depressed but the brakes did not control the vehicle. The brake system could fail to operate for two possible reasons: The driver may react incorrectly to the incident (for example, by delaying brake application or not depressing the pedal at all); or the brake system

may malfunction. Driver-related issues are described in Section 7, while Section 6 focuses on the brake system itself, particularly the hydraulic power assist. The power-assist mechanism reduces the force the driver must apply to stop the vehicle. To produce 0.3 g of deceleration, a brake-pedal force of 22.5 lb-f would be required with the assist working. However, if the assist does not function, the required pedal force increases to 90 lb-f. The hydraulic assist is capable of temporarily malfunctioning, but only under the conditions not characteristic of SAIs. Even without power assist, the great majority of drivers would be able to prevent an SAI with the brakes. This is further explained in Section 6.

3. IDLE-STABILIZATION SYSTEM

3.1 INTRODUCTION

The idle bypass system is found in 1984 and later Audi 5000 models with fuel injection. (Prior models used an electrically heated air regulating valve for the cold-start function.) An idle-stabilization system maintains a constant idle speed while adjusting to different load conditions. As shown in Figure 3-1, TSC's study was based on two possible situations:

1. The valve itself is defective (broken spring, sticking bearings, intermittent commutator).
2. The electronic control unit (ECU) operates incorrectly.

3.2 SYSTEM DESCRIPTION

The idle stabilizer is a linear-actuated valve on the 1984 Audi 5000S and 1984 to 1986 Audi 5000 Turbo models, and is a rotational-actuated valve on the 1985 to 1987 Audi 5000S models. A schematic of the stabilizer valve and control system is shown in Figure 3-2. Incoming air is regulated by the valve, which is electrically operated. Adjusting the flow of "metered" air causes the engine to change power and speed.

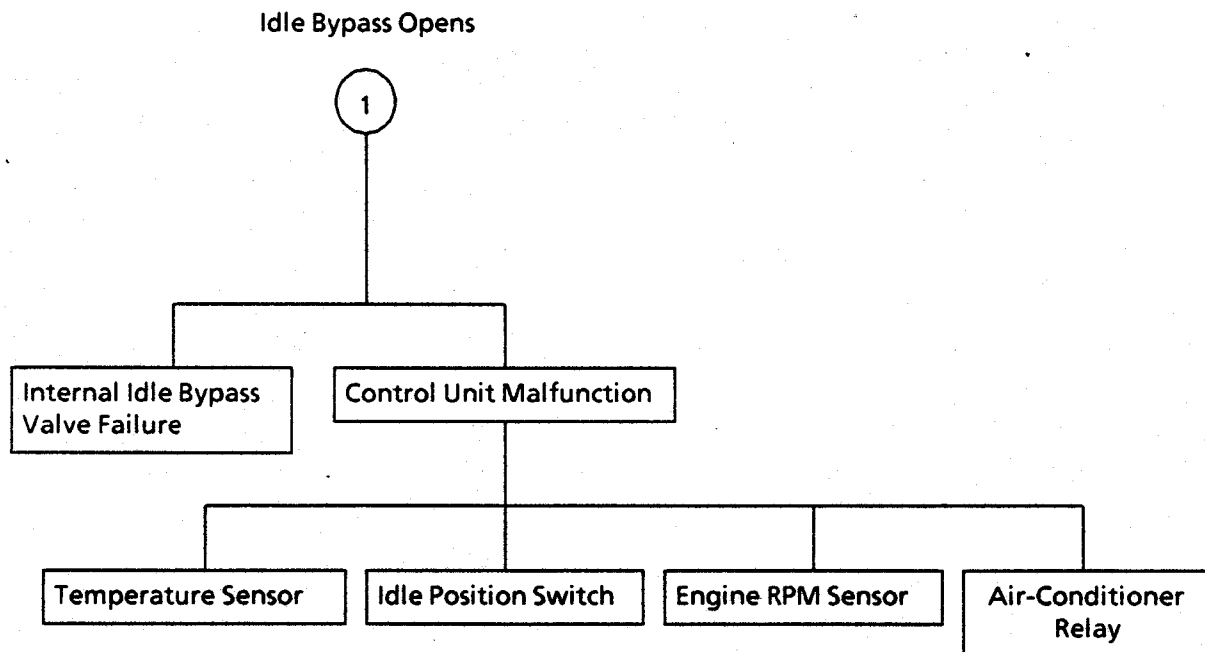
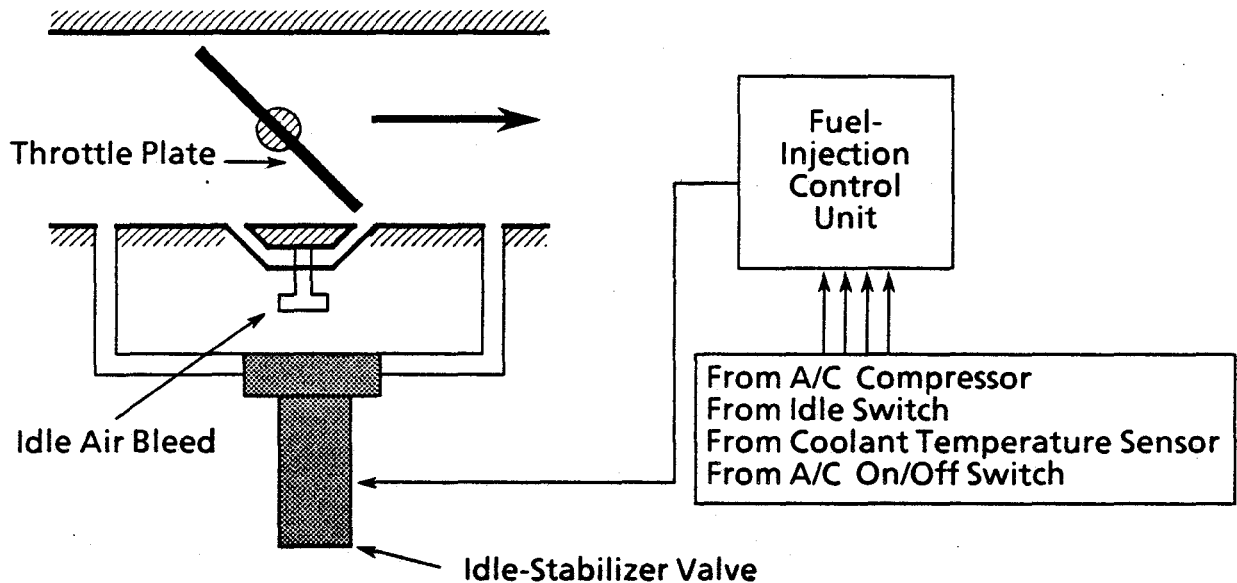

FIGURE 3-1. FAULT TREE ANALYSIS: IDLE BYPASS SYSTEM



SOURCE: CIS-Electronic Fuel Injection Service Training Manual 1986, 20.

FIGURE 3-2. IDLE-STABILIZER VALVE LOCATION AND CONTROLS

The fuel-injection control unit controls the idle-stabilizer valve on the 1985 through 1987 model years while the 1984 system has a separate control unit specifically for the stabilization system. The control unit monitors the engine RPM, engine coolant temperature, throttle plate state, air-conditioner on/off switch, and air-conditioner clutch operation. Based upon the measurements taken, the control unit chooses the appropriate engine idle RPM from three preset options:

Engine coolant temperature < 40° C	1000 RPM
Engine coolant temperature > 40° C	800 RPM
Engine coolant temperature > 40° C and air conditioner on	920 RPM

These preset values vary slightly in different versions of the system. The ECU is designed to limit its maximum output current whenever the throttle plate is open. After the proper RPM is selected, the control unit commands the idle-stabilizer valve to increase or decrease the airflow to change the engine RPM.

3.3 VEHICLE PERFORMANCE WITH IDLE-STABILIZER VALVE FULLY OPEN

In response to requests from NHTSA, VWOA provided plots of engine torque versus engine speed for the range of throttle plate opening angles for the Audi 5000S engine. VWOA also conducted tests of the vehicle and engine performance with the transmission in gear and the idle-stabilizer valve fully open. These tests were also made with the throttle plate open to an angle of 20°. Table 3-1 lists the engine speed developed at the start of the tests with the brakes fully applied and the transmission in gear. Measurements corresponding to this condition were also made at TSC on a 1986 5000S Turbo vehicle.

Based on this data, it is estimated that fully opening the idle-stabilizer valve corresponds to a 13.5° throttle plate opening for the 1984 5000S, a 21.3° throttle plate opening for the 1986 5000S, and a 14.3° throttle plate opening for the 1986 Audi 5000S Turbo (see Figure 3-3).

Calculations were performed by TSC using the engine torque versus speed characteristics to estimate the acceleration and velocity time histories of a 1986 Audi 5000S with the throttle plate open to an angle of 20°. This result is compared to the Audi test results in Figure 3-4, where the idle-stabilizer valve is fully open and the transmission is in reverse gear.

It can be seen that the calculations generally agree with the measurements for vehicle speeds between 4 and 19 mph. The smaller starting acceleration measurement is believed to be the result of delays in fully releasing the brake. The difference at speeds above 19 mph resulted from the test being terminated before the final speed was achieved. TSC calculations indicate that if the test had not been terminated, a sudden opening of the idle-stabilizer valve would result in an initial acceleration of 0.3 g's with the vehicle in reverse gear with no brakes applied, achieving a velocity of 24 mph in approximately 10 seconds. In these 10 seconds the vehicle would travel about 230 ft (see Figure 3-5). As shown in Figure 3-6, the final speed of the vehicle achieved in 30 to 40 seconds would be between 28 and 33 mph.

TABLE 3-1. TEST RESULTS

VWOA Tests*

Engine RPM**	Vehicle Model
1493	1984 Audi 5000S (rotary valve, fully open)
1897	1984 Audi 5000S (20° throttle angle)
2013	1986 Audi 5000S (rotary valve, fully open)
2128	1986 Audi 5000S (20° throttle angle)
1536	1986 Audi 5000S Turbo (linear valve, fully open)
2127	1986 Audi 5000S Turbo (20° throttle angle)

TSC Tests

Engine RPM**	Vehicle Model
1400	1986 Audi 5000S Turbo (linear valve, fully open)
1400	1986 Audi 5000S Turbo (rotary valve, fully open)

* Test results received by TSC through ODI from VWOA

** RPM measurement with brake fully applied and vehicle in reverse gear

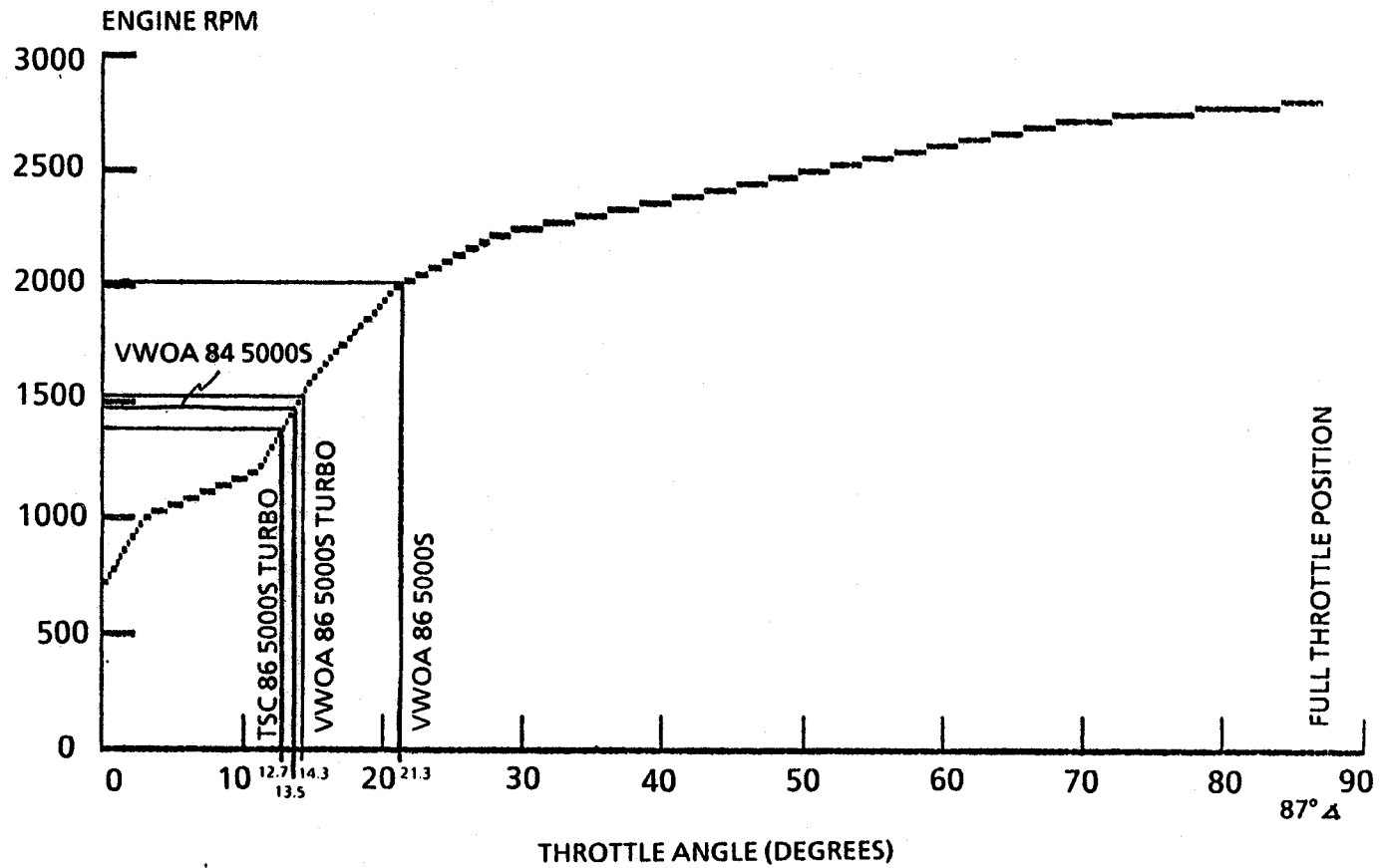

SOURCE: Based on TSC and VWOA test data.

FIGURE 3-3. ENGINE RPM VERSUS THROTTLE ANGLE IN REVERSE GEAR WITH BRAKES APPLIED

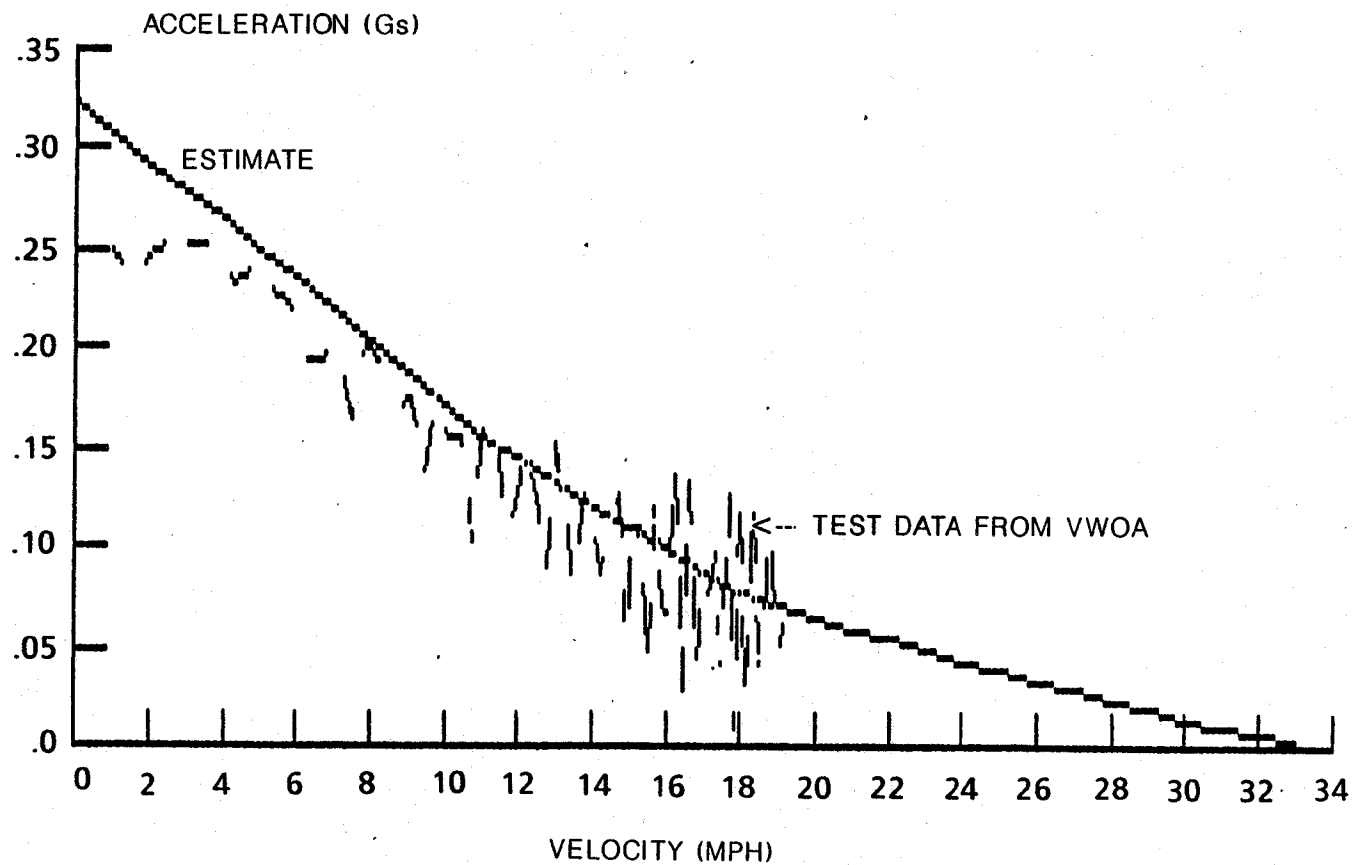

SOURCE: Based on TSC calculations and VWOA test data.

FIGURE 3-4. VEHICLE ACCELERATION VERSUS VELOCITY FOR A 1986 AUDI 5000S IN REVERSE GEAR WITH A 20° THROTTLE ANGLE (without brakes applied)

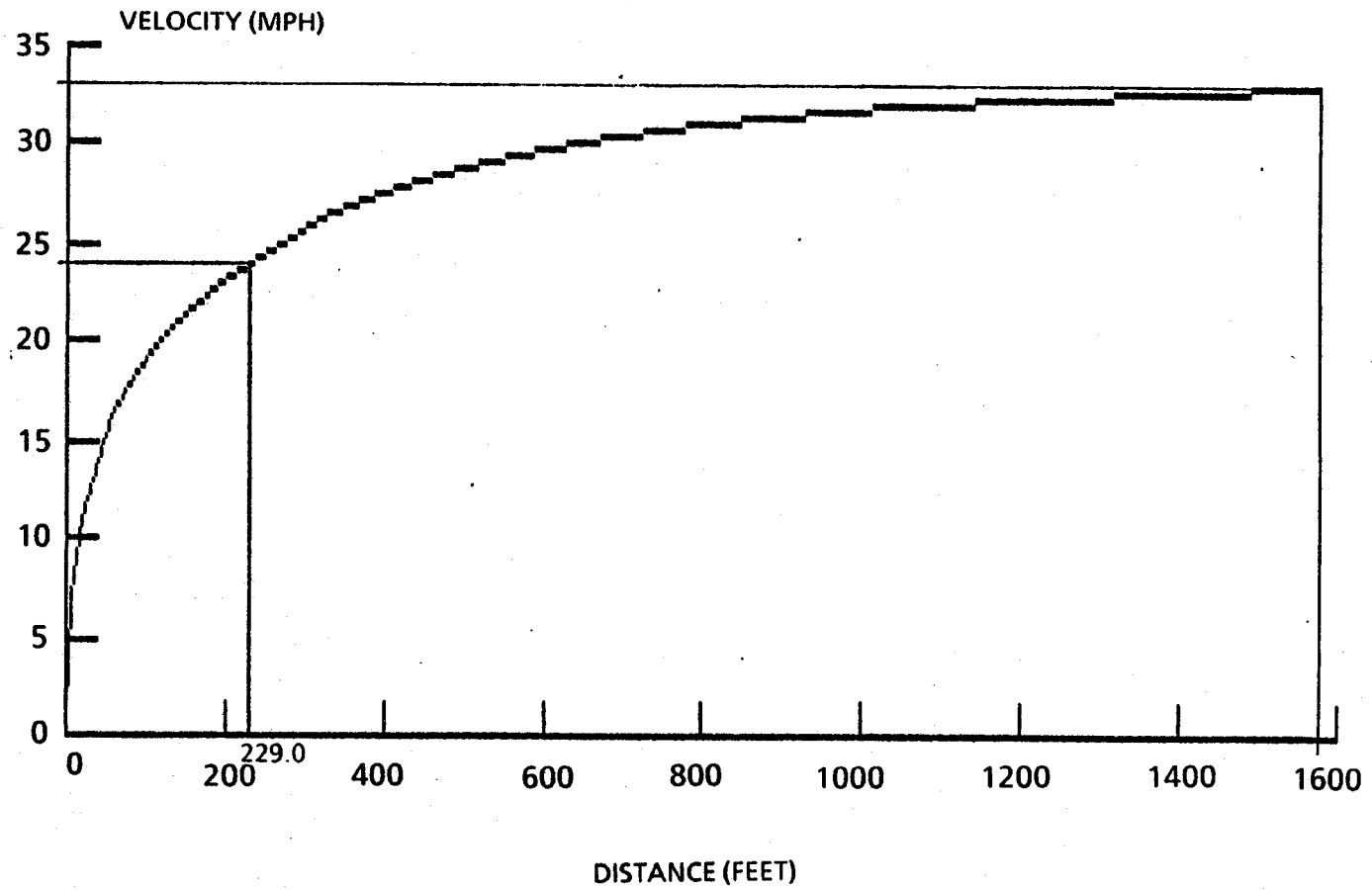

SOURCE: Based on TSC calculations.

FIGURE 3-5. VEHICLE VELOCITY VERSUS DISTANCE FOR A 1986 AUDI 5000S IN REVERSE GEAR WITH A 20° THROTTLE ANGLE (without brakes applied)

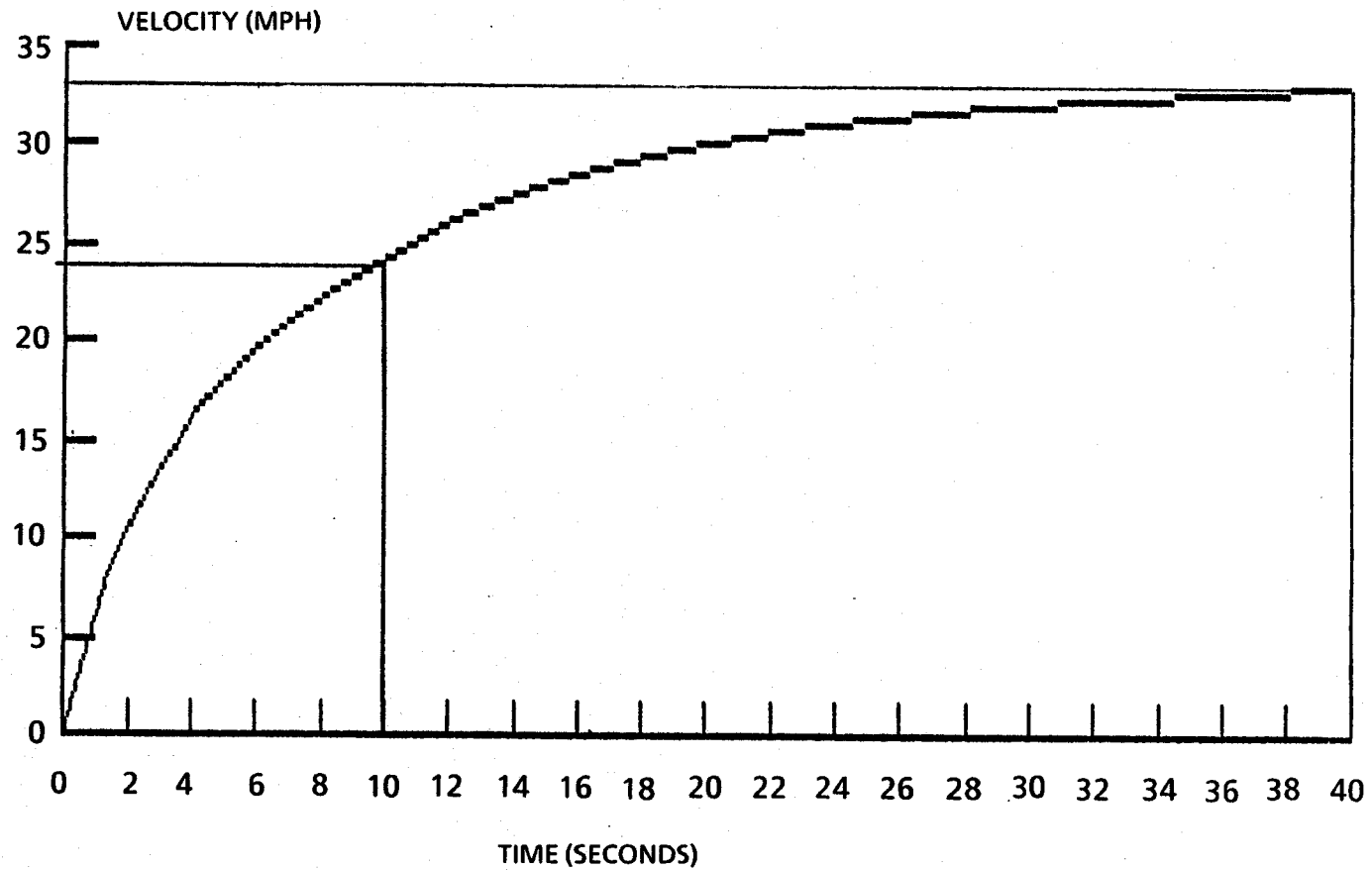

SOURCE: Based on TSC calculations.

FIGURE 3-6. VEHICLE VELOCITY VERSUS TIME FOR A 1986 AUDI 5000S IN REVERSE GEAR WITH A 20° THROTTLE ANGLE (without brakes applied)

3.4 CONTROL UNIT AND SENSORS

Airflow is determined by the electrical current passing through the stabilizer valve, which is set by the ECU, as shown in Figure 3-7. As mentioned above, two significantly different versions of the valve and controller are in use: the rotary and the linear. The former uses a three-wire system with +12 V DC applied to pin 2. Pins 1 and 3 return to ground through the ECU. The relative proportions of time that current is permitted to flow in each side of the circuit by the controller determine the valve position.

The following test data were recorded by TSC. In the linear valve, Figure 3-8, a spring exerts a closing force. A single solenoid opens the valve by an amount which is proportional to the strength of the current flowing through it. This current normally consists of a pulse train with a frequency of 140 to 150 Hz. The width of the "on" pulses varies from about 1.2 msec at an idle speed of 800 RPM to around 1.5 msec for 1000 RPM. Nominal current for a warm engine is about 430 mA (equivalent DC current). Switching on the air conditioner causes the ECU to increase the current by 60 to 70 mA. The ECU also receives inputs from a temperature sensor and a switch on the throttle. When the engine temperature is below 40° C, an additional 100 mA are provided. When the throttle is open, the working range of currents provided by the ECU is reduced, but it usually remains close to the above-mentioned values.

The most important input to the ECU is engine RPM, taken from the ignition coil primary. These pulses are fed to a frequency-to-voltage converter circuit in the ECU. After passing through a filter stage, a smoothed voltage proportional to engine speed is obtained. This voltage is then compared with a reference voltage, the value of which is dependent upon engine temperature and whether or not the air conditioner is in use. If the actual engine speed proportional voltage is lower than the reference, an output signal is sent to the pulse-width modulator to increase the duty cycle; the converse is true when proportional voltage exceeds the reference voltage. The output from the modulator is then amplified to control the effective current through the idle-stabilizer valve. Figure 3-9 shows the block diagram for the ECU.

The ECU circuitry consists of a dozen operational amplifiers, a few discrete transistors, about 80 resistors and capacitors, and a few other components. These are mounted upon a pair of circuit boards, each measuring 59 by 54 mm, and joined by a ribbon cable. The two are then folded together so they can be inserted into a molded plastic housing with external dimensions of 61 by 62 by 31 mm. Figure 3-10 shows both boards spread out.

3.4.1 Failure Analysis

In an electronic device as complex as the ECU, there are hundreds of potential failures. Each of the nearly 100 discrete parts can open, short, or drift from its nominal value. Furthermore, each has two or more solder joints which may open, usually intermittently. Each of the integrated circuits has a large number of potential failure modes. Fortunately, the normal failure rates for all these devices are extremely low. Mean times between failures (MTBF) on the order of millions of hours are the norm as long as electronic components are used within their rated environmental limits. However, as a rule of thumb, each 10° C temperature rise reduces MTBF by an order of magnitude.

Of these hundreds of possible failure modes, a great many reduce or completely cut off current flow through the valve. As a result, the car will be difficult to drive because of engine stalling, but this poses no other safety hazard.

Of far greater concern are those failures leading to abnormally large currents. Some of these produce only a moderate increase in valve opening. ODI has supplied data indicating that Canadian

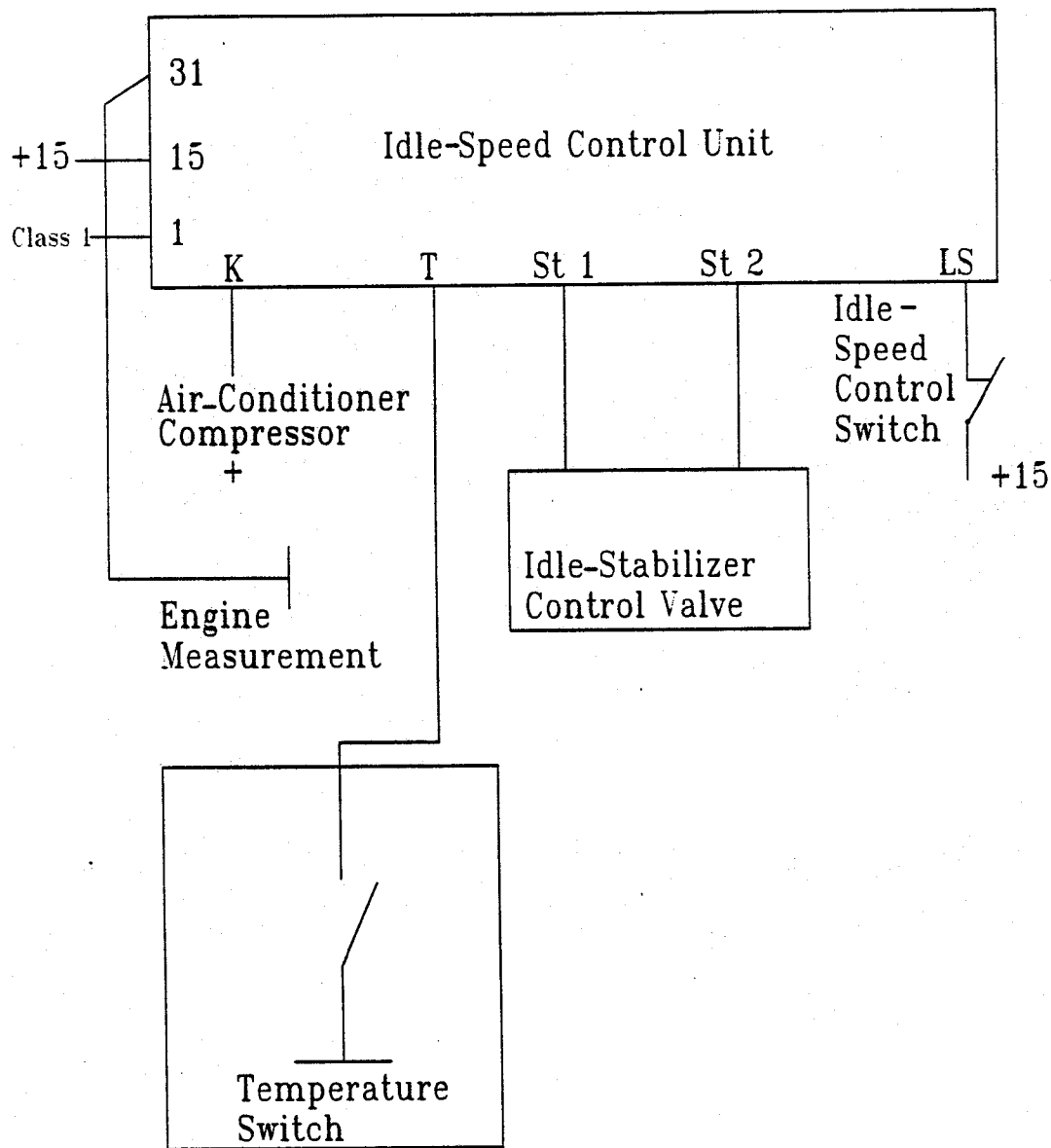

SOURCE: From VWOA through ODI to TSC, translated to English from German by TSC.

FIGURE 3-7. WIRING DIAGRAM FOR THE IDLE-STABILIZATION CONTROL SYSTEM

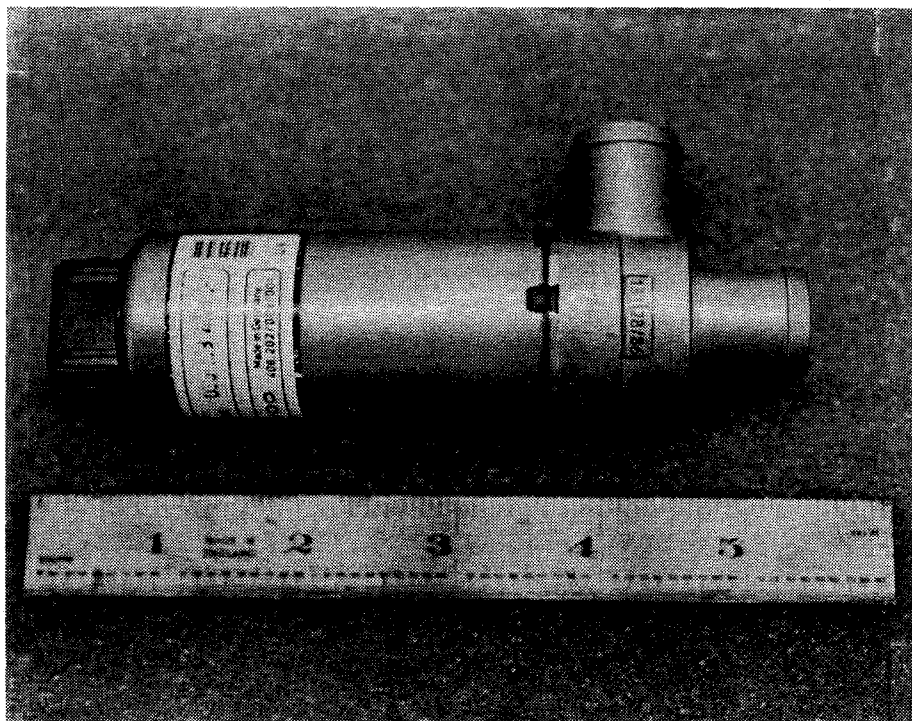
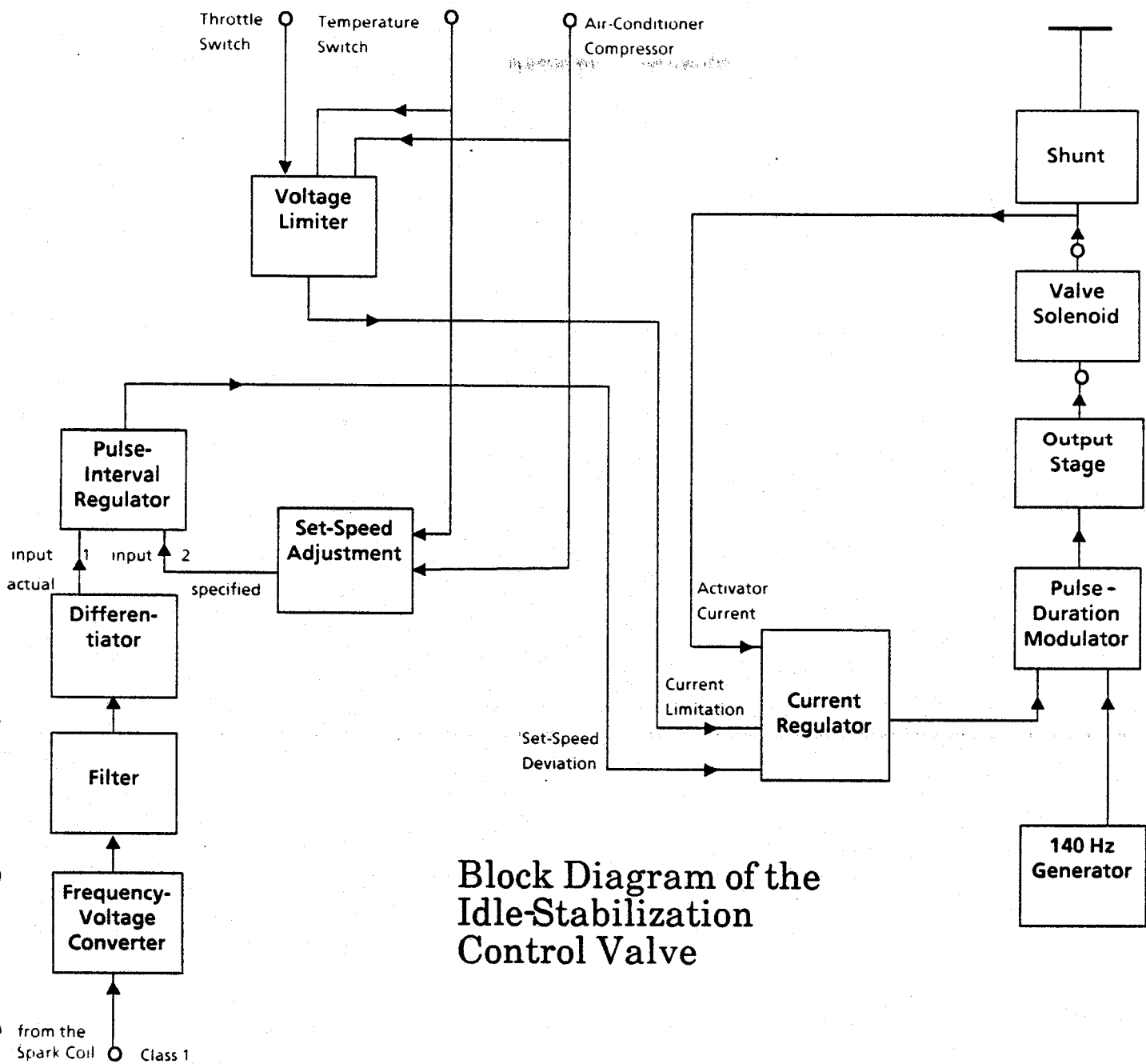

FIGURE 3-8. LINEAR-ACTUATED IDLE-STABILIZATION VALVE



SOURCE: From VWOA through ODI to TSC, translated to English from German by TSC.

FIGURE 3-9. BLOCK DIAGRAM OF THE IDLE-STABILIZATION CONTROL VALVE

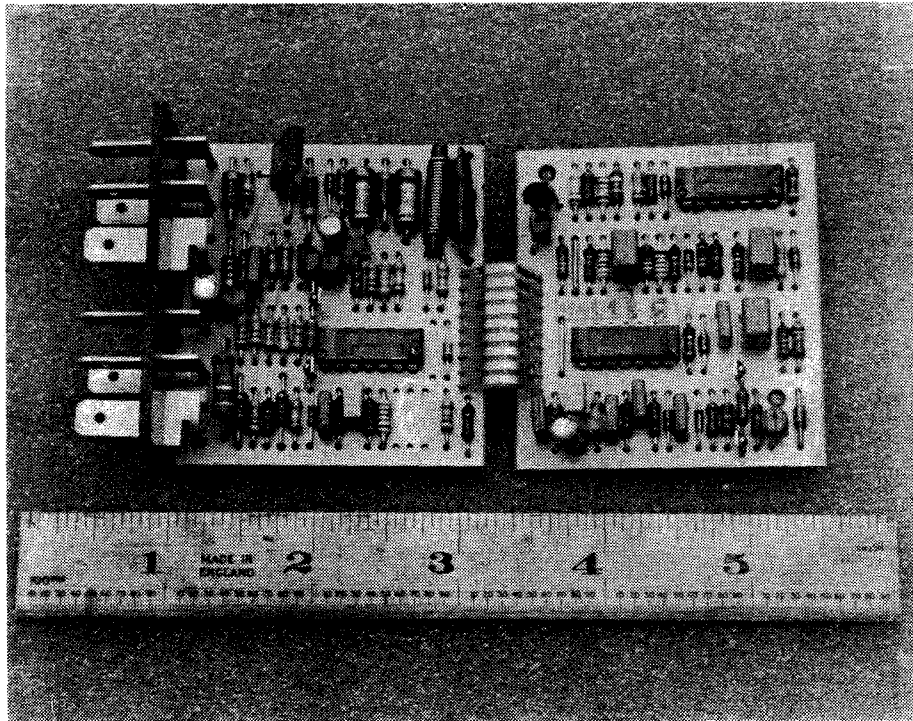

FIGURE 3-10. CIRCUIT BOARDS COMPRISING THE ELECTRONIC CONTROL UNIT (ECU).

investigators found an intermittent solder joint on a capacitor in the circuit which smoothes the output from the frequency converter. This fault led to an idle speed of about 1800 RPM.

Most serious are the faults which drive maximum current through the valve. Full valve opening is achieved with about 1 amp, which can produce an initial acceleration of up to 0.3 g. Level road speeds of about 40 mph in drive or 33 mph in reverse can result.

Among the most likely causes of high current faults are shorts in the output transistor, T145, or the driver transistor, T143, shown in Figure 3-11. Shorts in either will lead to currents limited only by the resistance of the valve and shunt, or about 2.3 amps. Such currents were, in fact, measured repeatedly during acceleration incidents with a test vehicle. These test results are contained in Appendix D.

Excessive temperatures in the ECU are the most likely cause of intermittent shorts in the output and driver transistors. TSC laboratory measurements of the case temperature of a driver transistor have shown it to be as much as 45° C above ambient. NHTSA field measurements on a hot, sunny day indicate initial ambient temperatures inside the ECU box can easily exceed 50° C. Thus, these components may be commonly exposed to temperatures above 70° C, which is considered the desirable upper limit for most commercial-grade devices.

In a laboratory experiment, one ECU which had tested normally for 2 weeks of continuous operation was placed in an environmental chamber. It continued normally until the temperature was raised to 55° C. Thereafter, even when operating at room temperature, it intermittently exhibited either normal behavior or one of four distinct abnormal modes. One of these abnormal states resulted in no output while another yielded about 25 percent of the normal current. The other two provided normal current but at greatly elevated pulse rates, 3.5 and 7 kHz respectively. Tapping or flexing the output transistor could cause the control to jump between fault states or back to normal. (Operation at normal current, but at a very high pulse rate of 28 kHz, was often exhibited by the ECU from the test car just prior to its intermittent jumps into the shorted, maximum-current fault mode. This observed high-frequency pulse was an indicator to a failure of high current.)

In addition to excessive temperatures arising from the ECU design combined with summer ambients, it is likely that the output transistors of some ECUs may have been damaged by faulty diagnostic procedures used by some mechanics. Testing the control requires measuring its output current. However, the ammeter must be inserted between the ECU and the valve, since there is a shunt resistor in the return to ground which provides essential feedback to the output stage. If this feedback is eliminated by connecting an ammeter from the low side of the valve to ground, the output stage will be driven full on and will overheat. Audi has acknowledged this problem and has added a current limiter to the most recent version of the ECU to make it invulnerable to such mechanic errors.

Another faulty ECU was tested for 2 months by TSC. During the first 2 weeks of testing there were 5 incidents in which the output current rose to about 1 amp. These faults were definitely not caused by the output stage, but the exact failing component was not determined. Following a thorough cleaning of the circuit board, no further incidents occurred in 6 weeks of testing. Hence, a possible explanation for the abnormalities in this unit is that a fleck of solder adhered to the board when it was assembled and caused intermittent shorts until it was removed during cleaning.

3.5 IDLE-STABILIZER VALVE

The rotary-type valve of the idle-stabilizer system was analyzed to determine if a malfunction in the valve could keep it open with a normally functioning control unit or if an improperly operating control unit could force the valve open. Three types of possible failures were examined: a mechanical sticking of the valve, an intermittent connection between the brushes and current collectors, and a broken return spring. Appendix A gives a detailed description of these possible failure modes.

Figure 3-12 (a) shows the orientation of the valve's electrical components and sign naming conventions. A diagram of the electrical circuit within the armature for normal operation is shown in Figure 3-12 (b). Pins 1, 2, and 3 are connected to brushes that run against a segmented current collector mounted to the armature. The rotary valve uses an armature that is not mechanically restricted to 120° of travel. Since the brushes are mounted 120° apart, the brushes can contact adjacent current-collector segments. If contact were to occur, the current in the windings would change direction and, in turn, reverse the torques applied by the windings. When the brushes contact adjacent current-collector segments, overrun conditions occur (see Appendix A). The two possible overrun positions are the overrun open (valve open) and the overrun closed (valve closed) positions. In the overrun condition, the torque required to hold the valve open is reduced. The torque needed to hold the valve open when the control unit is sending a closing duty cycle while the armature is in the overrun open position is about 4.5 oz-in. To develop this torque a mechanical sticking must occur. Mechanical sticking could be caused by a bearing failure or a brush-current-collector failure. In the event of a bearing failure, the mechanical sticking is developed by the binding of the armature bearings onto the support shaft. In the event of the brush-current-collector failure, arcing of the brush and the collector causes the brush to weld itself to the collector. Under both of these mechanical failures, the valve would not return to proper operation and physical evidence of a defective valve would remain after an SAI. If the valve was in the overrun open position and all the components functioned properly, the valve would always return to the commanded equilibrium position.

A second type of failure would occur if the current collector deteriorated at some location that would cause it to become insulated from the brushes (i.e., create a dead spot). The dead spot would interrupt the flow of current being sent by the control unit. The resulting interruption in current would reduce the torque produced by the winding and allow the return spring to return the armature to the neutral position. As the armature starts to return to the neutral position, the dead spot is bypassed and the current starts to flow again. This intermittent opening of the circuit would cause the valve to develop large oscillations that would produce engine surging and perhaps a premature fatigue failure of the spring. It has been reported by ODI that some of the idle-stabilizer valves replaced by the recall campaign (July 1986) caused engine surging up to 3800 RPM in neutral or park.

If the spring failed due to large oscillations, the valve would still operate. Without the resisting torque of the spring, the valve would respond faster to the signals present and have a greater tendency to enter the overrun condition. Figure 3-13 shows the condition where the valve is commanded to fully close and the spring is broken. If the valve started above the 94° position and received the command to close, the closing torque of -8.3 oz-in would change to an opening torque of 6.0 oz-in. Even with a closing signal, this change in torque would cause the valve to continue to open. If the spring were broken or defective and the valve was in the overrun open position, a normal closing signal would continue to open the valve. If the power were shut off after an overrun condition and the valve drifted to less than 94°, the valve would return to the broken spring operation. During broken spring operation the engine might surge to a greater extent than normal, without necessarily seeming out of the ordinary. Testing the valve according to the Audi Factory Repair Manual could show normal valve operation. This test checks the engine RPM at the 28 percent duty cycle as

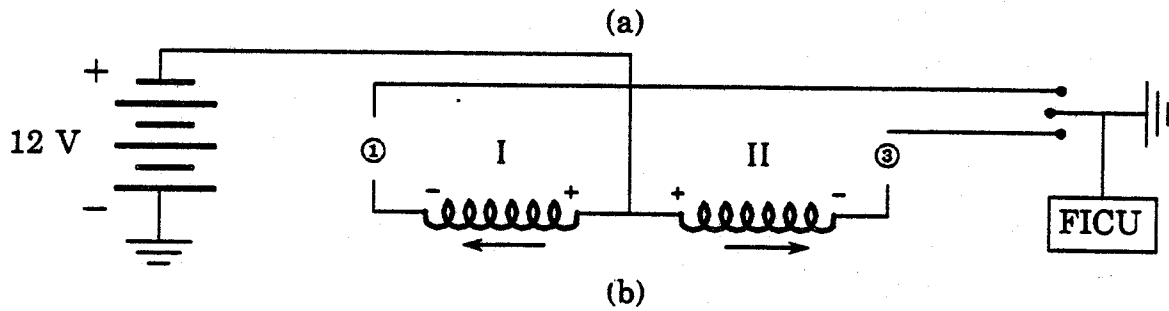
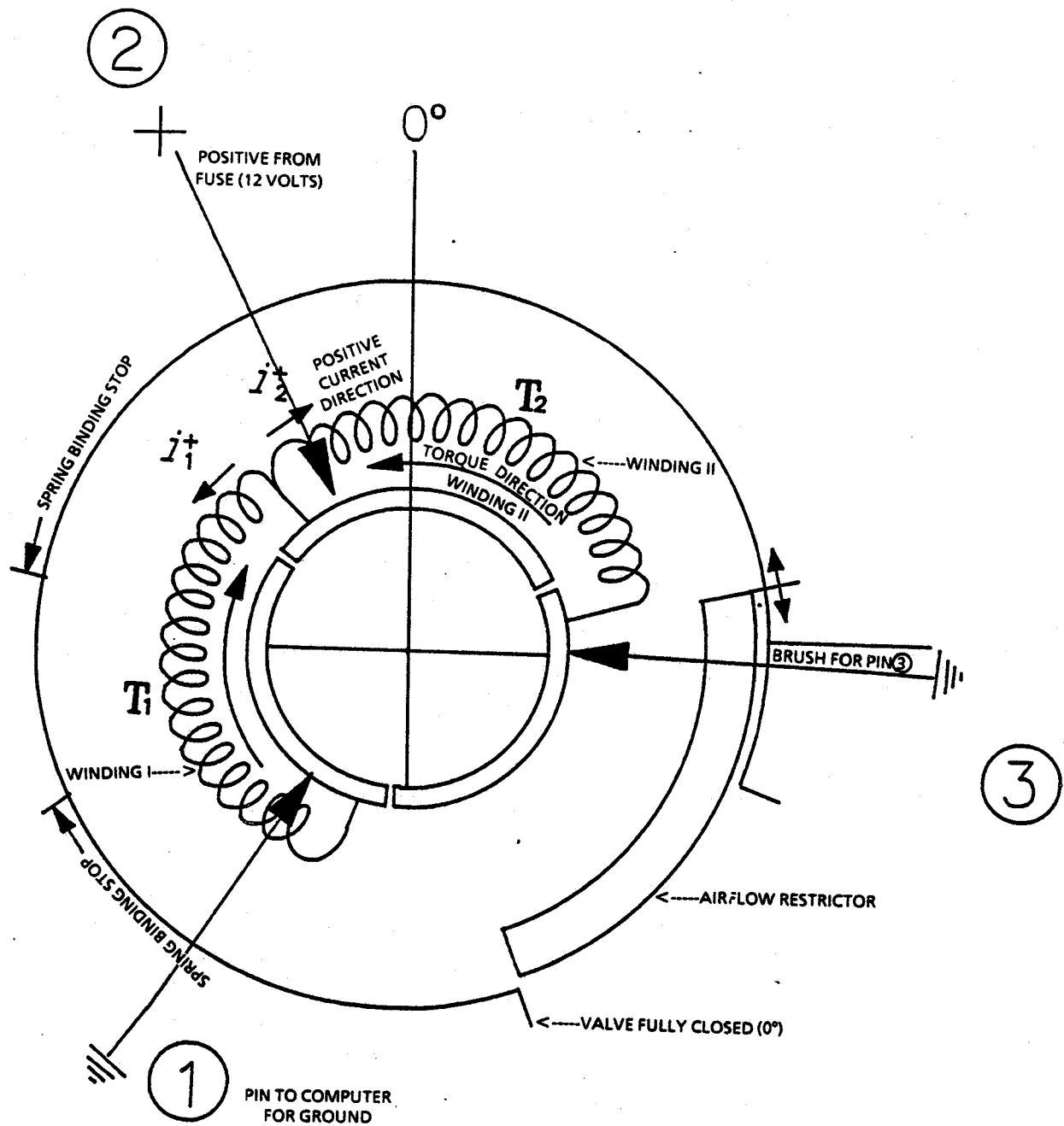
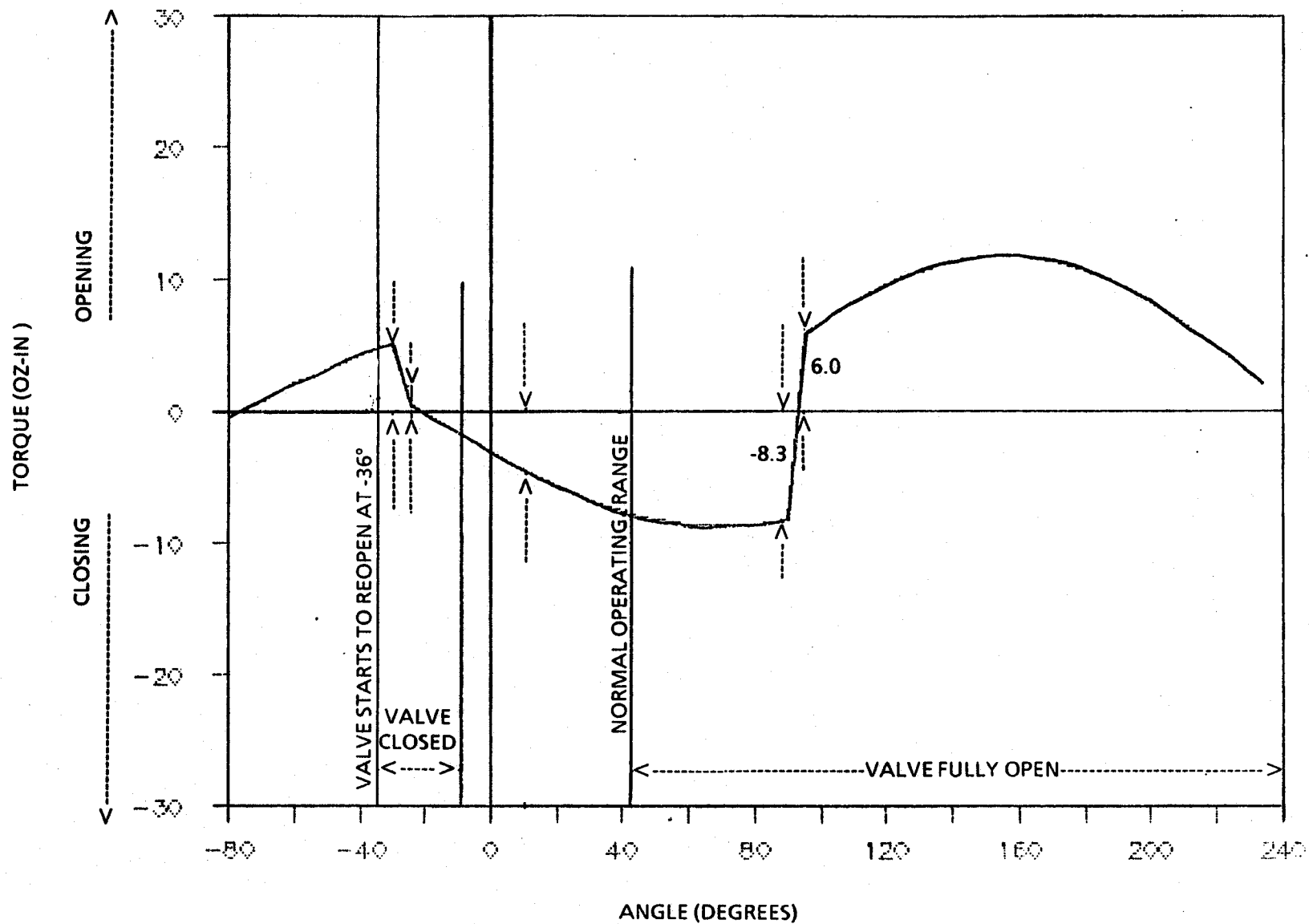

FIGURE 3-12. ORIENTATION OF VALVE COMPONENTS AND SIGN CONVENTIONS UNDER NORMAL OPERATION

GROUND TO PIN #1



3-17

FIGURE 3-13. TORQUE ON ARMATURE VERSUS VALVE OPENING ANGLE FOR THE COMMAND TO FULLY CLOSE WITH SPRING BROKEN

NEUTRAL POSITION

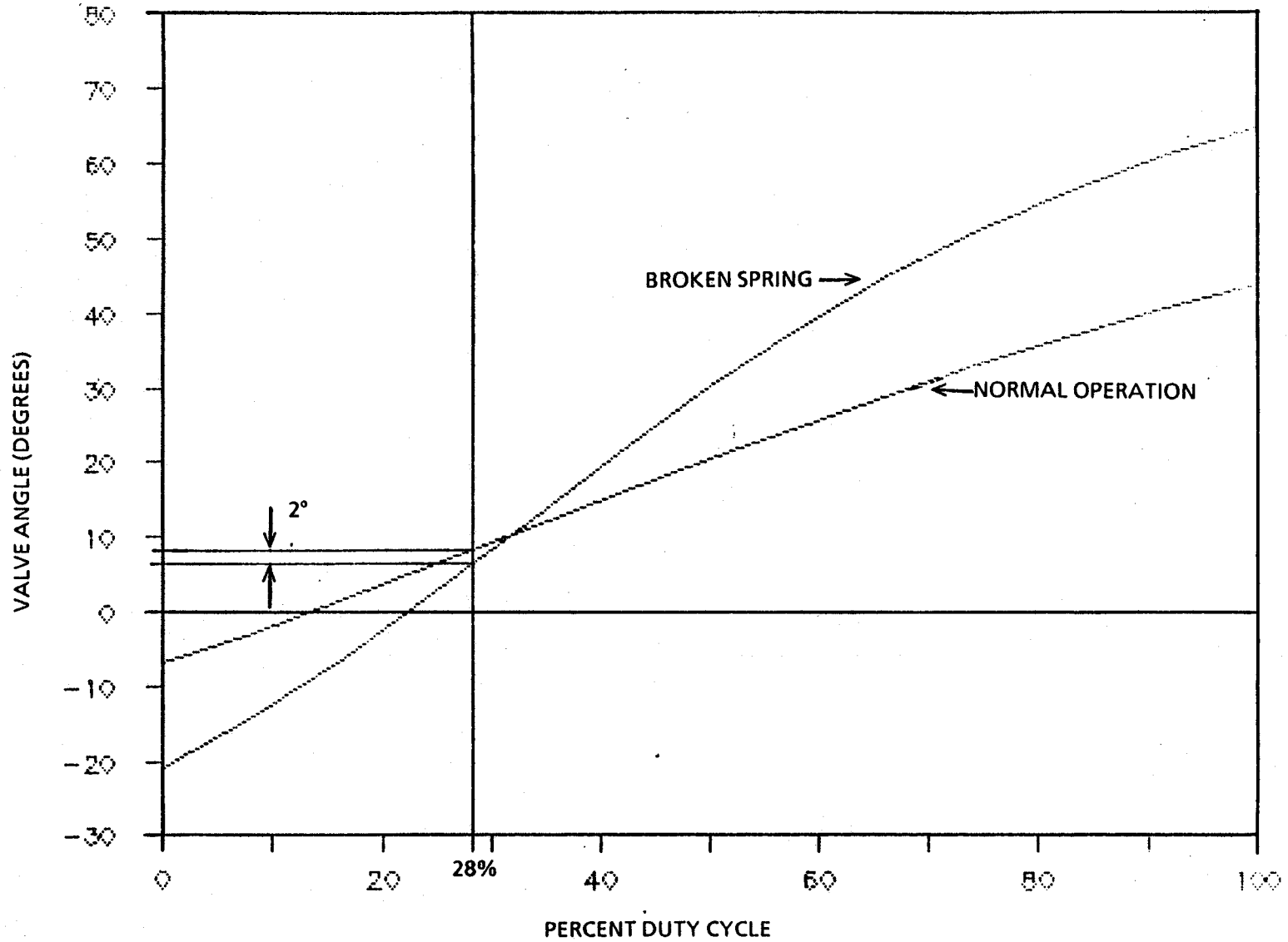

3-18

FIGURE 3-14. OPENING ANGLE OF VALVE AS A FUNCTION OF PERCENT DUTY CYCLE ON WINDING 1 DURING NORMAL AND BROKEN SPRING OPERATION

described in Appendix A. As shown in Figure 3-14, at the testing location of 28 percent, the difference in the valve angle with and without the spring is about 2.0° . The mechanical sticking or the intermittent connection failures are easily detected by inspection or by the condition of the engine idle. Of the three possible valve failures, only a broken spring failure could cause the valve to remain fully open with the control unit sending a normal closing signal, and then properly operate after the power has been shut off. The standard tests used to determine the valve's condition would not detect a broken spring unless in the overrun condition. If the spring is broken, the chances of the valve overrunning are high, causing multiple incidents to occur with a single valve. This is not typical of SAIs.

4. CRUISE CONTROL SYSTEM

4.1 INTRODUCTION

Because the cruise control system is capable of opening the throttle plate fully, it was closely studied and preliminary, limited bench testing of four units was performed. Figure 4-1 summarizes failure possibilities with the cruise control system. The cruise control system maintains a constant vehicle speed that has been set by the driver through a computer control unit that monitors the difference between the driver's preset speed and the vehicle's actual speed. The control unit then adjusts the vehicle's speed by adjusting the engine's power. Engine power is changed by adjusting the throttle position. A pneumatic system was used to open the throttle plate on models from 1984 to the present. Previous to 1984, some of the vehicles used an electrical system to open the throttle plate. The control unit for the 1978 to 1983 models was an analog design. After 1983, the control unit was converted to a digital design. The pneumatic system is covered in more detail since it is still being used in the new Audi 5000.

4.2 PNEUMATIC SYSTEM

The components of the pneumatic system are shown in Figure 4-2. They include a vacuum pump, a vacuum motor, a mechanical air bleed, an electrical air bleed, the linkage, and the throttle return spring. The pneumatic system of the cruise control opens and closes the throttle plate. When a vacuum is applied to the vacuum motor, the throttle plate opens. A decrease in vacuum allows the return spring to close the throttle plate. The vacuum level is adjusted by the control unit. When driving conditions demand an increase in vehicle speed, the control unit activates the vacuum pump. If a decrease in vehicle speed is needed, the control unit opens an electrical air bleed that allows atmospheric pressure into the system. As a result, the throttle plate closes. Fine control of vehicle speed can be maintained with this system.

When the brakes are applied, a mechanical air bleed and an electrical switch are activated. The electrical switch sends a signal to the control unit to open the electrical air bleed and turn off the vacuum pump, while the motion of the brake pedal mechanically opens the mechanical air bleed. Immediately after the air bleeds are opened, the vacuum in the vacuum motor is emptied and the throttle plate returns to the fully closed position.

4.3 CONTROL UNIT AND SENSORS

The control unit receives signals from the brake switch, an induction generator, and the driver's operating switch. The control system is shown in Figure 4-3. Mounted behind the speedometer and attached to the speedometer cable, the induction generator develops a signal based on how fast the vehicle is traveling. The driver's operating switch turns the system on and off, sets the vehicle speed, and initiates the resume function. The power to the cruise control system is supplied through the neutral safety switch and the operating switch. The neutral safety switch allows power to the control unit only when the transmission is either in drive or in second gear. If either the neutral safety or operating switch is off, there is no power to the control unit. The electrical air bleed is normally open when there is no power to the control unit. The set switch sends a signal to the control unit to record the current vehicle speed and activate the control system to maintain this speed. The resume switch sends a signal to the control unit to restart the cruise system and maintain the last preset speed. The control unit does not allow these functions to be invoked until the vehicle speed is above 30 mph. To deactivate the cruise system, the brake pedal is depressed or the operator switch is turned off.

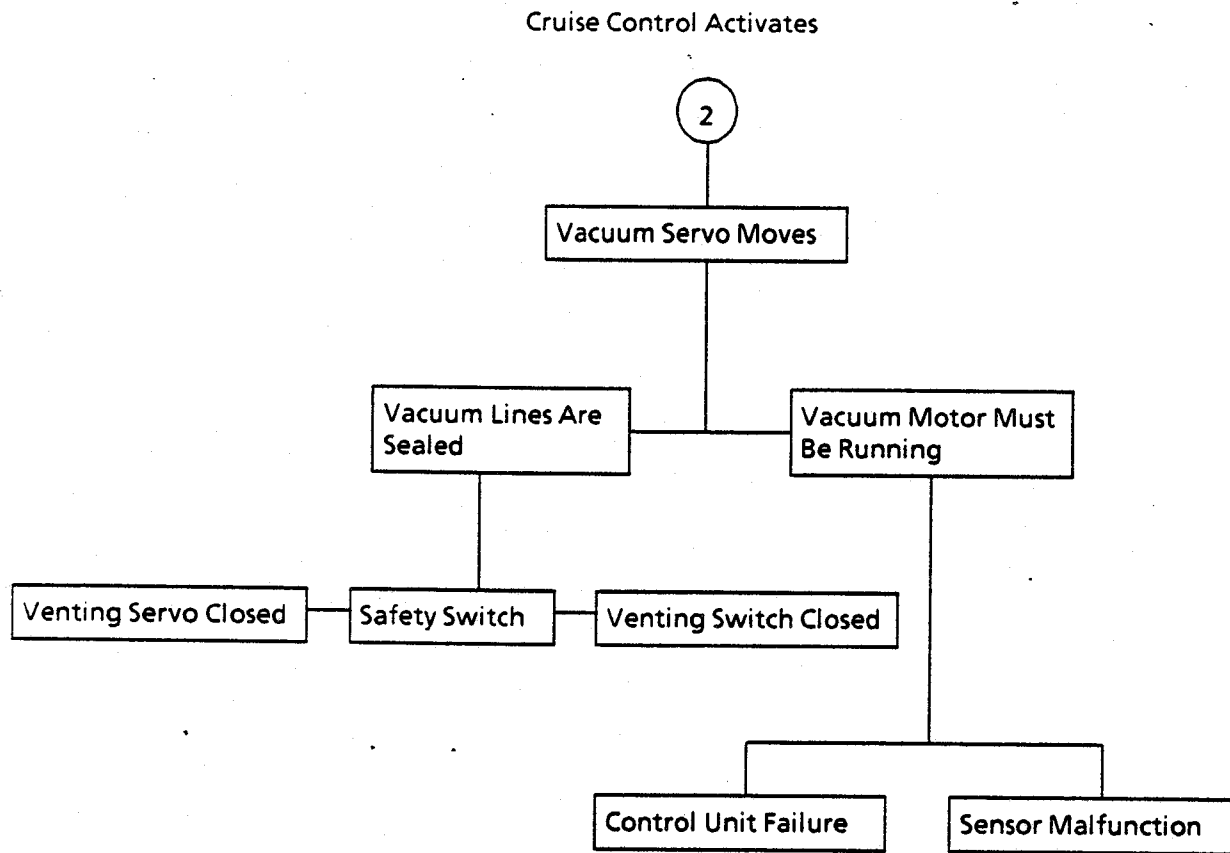

FIGURE 4-1. FAULT TREE ANALYSIS: CRUISE CONTROL

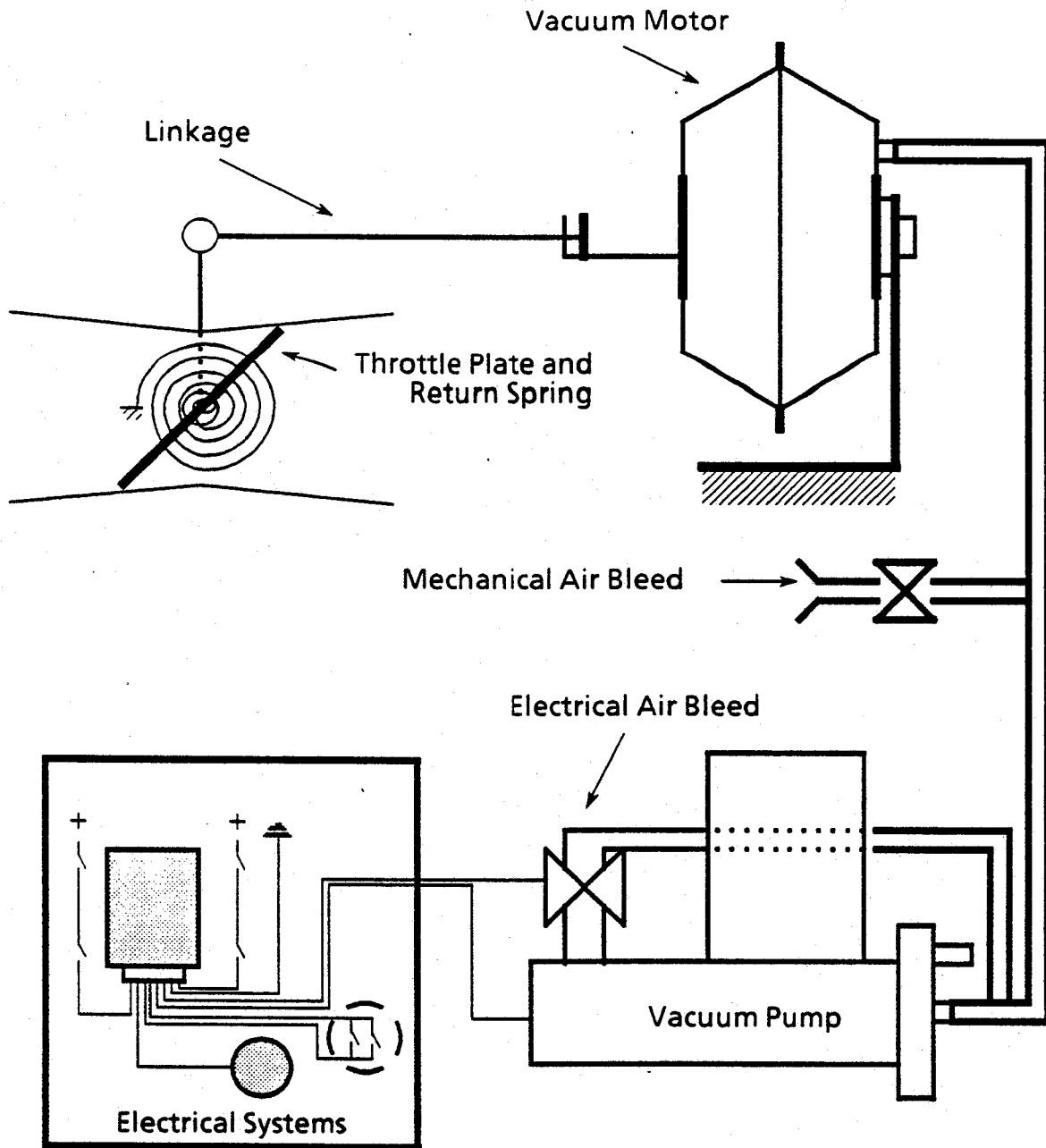

FIGURE 4-2. CRUISE CONTROL PNEUMATICS SYSTEM

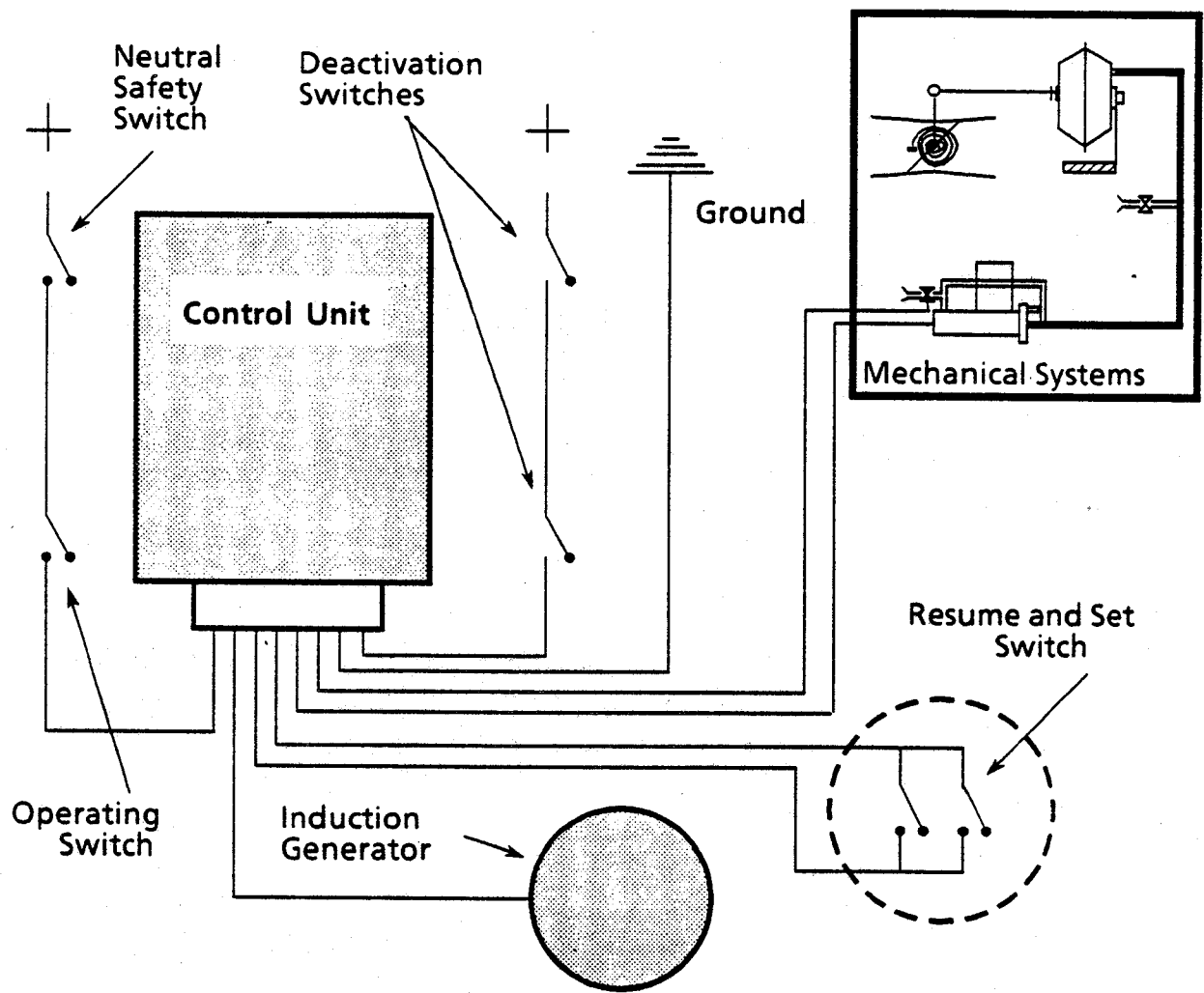

FIGURE 4-3. CRUISE CONTROL COMPUTER CONTROL SYSTEM

4.4 POSSIBLE MODES OF MALFUNCTION

For the cruise control to cause an SAI, the vacuum pump must be operating and both the electrical and mechanical air bleeds must be closed. The vacuum pump and the electrical air bleed are operated by the control unit. A total malfunction of the control unit could open the throttle plate and cause an SAI; however, for this to occur, certain conditions must be met. The control unit is supplied power through the neutral safety switch and the operator switch. Therefore, the vehicle must be either in drive or in second gear, the operator switch must be on, and the brake pedal must not be depressed. If any of these conditions are not met, no SAI could occur. After the SAI has occurred, drivers typically report that the cruise control system operated normally. In addition, SAI reports show that the accidents happen 50 percent of the time in reverse. There is no power to the cruise control in reverse gear even with the operating switch on, unless the neutral safety switch is somehow defective. Such a defect, however, would prevent the vehicle from starting at all.

4.5 CRUISE CONTROL BENCH TEST

Given the case that the vehicle was in drive and the brake pedal was not depressed, it is theoretically possible that certain malfunctions in the cruise control could lead to throttle opening. In the older, analog controller used prior to model year 1984, a single open solder-joint in the final operational amplifier circuit could conceivably cause throttle opening. Other failure modes for this controller and all failure modes for the microprocessor-based controller used after 1983 would require two or more independent component failures to produce throttle opening. For such failures to cause a throttle-opening incident and yet be difficult to diagnose after the fact, they would have to be of an intermittent nature.

In order to test for the possibility of such intermittent failures, TSC constructed an apparatus in which Audi cruise controls could be operated for extended periods of time with continuous monitoring for fault conditions in the output circuits. This test jig consisted of an Audi vacuum pump, vent and servo together with a power supply, appropriate switches for the "set," "resume" and "brake" inputs, and a pulse generator to simulate the input from the vehicle speed sensor. This jig was placed inside a manually controlled oven so that it could be operated at a temperature of 150 F. because elevated temperatures frequently precipitate electronic failures.

The status of the outputs to the vacuum pump and vent valves was monitored continuously by a digital memory oscilloscope accessory attached to a personal computer. If either of the outputs switched on, however briefly, a record of the anomaly was made.

Each of four Audi controllers (three micro-processor, one analog) was operated for two weeks in the oven at 150 F. From time to time additional thermal stress was applied by manually spraying the circuit boards with freezing mist. During the two months of testing, several anomalies with durations of less than a tenth of a second were recorded. These were probably caused by power surges in the building electrical system (EMI). In no case could they have resulted in measurable throttle opening. No faults of any relevance to SAI were observed.

5. TRANSMISSION

5.1 INTRODUCTION

Because of the direct link between the throttle valve of the engine and the kickdown valve of the transmission, there is a possibility of the transmission, through the linkage, opening the throttle. The transmission can only affect operation as described in this section in 1978 through 1983 Audis; 1984 and later models have reconfigured transmissions for which it is impossible to open the throttle plate by the throttle valve. However, in these later models the transmission gearshift linkage could possibly bind, which would also cause the throttle plate to open.

The following is a discussion of the linkage between the engine and the transmission, and the operation of the automatic transmission. Figure 5-1 shows the linkage fault tree analysis.

5.2 ENGINE/TRANSMISSION LINKAGE DESCRIPTION

Figure 5-2 shows a schematic of the throttle linkage and the transmission gearshift linkage. The throttle linkage consists of the accelerator pedal and lever, one cable, and five links. The transmission shift linkage consists of the selector lever, a cable, and the shift lever on the transmission. The solid arrows in Figure 5-2 indicate the direction of motion of the links of the throttle linkage when the accelerator pedal is depressed and the dashed arrows indicate the direction of motion when the gear selector is moved from the 'park' position into the 'reverse' or 'drive' position.

When the accelerator pedal is depressed the throttle cable is pulled, which, through five links, opens the throttle plate. The accelerator linkage operating lever, to which the cable is connected, pivots within the shaft of the gearshift linkage selector lever on the transmission. Figure 5-3 shows an exploded view of the selector lever and shaft and the operating lever and how they are mounted on the transmission. The selector lever is mounted on a hollow shaft that goes through the transmission case. The shaft is held in place by a bushing bearing in the transmission case and the manual valve lever is mounted on the shaft inside the transmission. Both levers are fixed to the shaft and when the outside lever - the selector lever - is rotated, the inside lever - the manual valve lever - also rotates. The manual valve lever then changes the position of the manual valve, which shifts from one gear to another. The operating lever is mounted on a solid shaft that is held inside the hollow selector lever shaft by a bushing bearing. Inside the transmission, the operating lever for the kickdown valve is mounted on the operating lever shaft. Again, both levers are fixed to the shaft and rotate together. The operating lever pushes in the kickdown valve; when the operating lever is rotated, the kickdown valve is depressed and the throttle plate opens simultaneously. (The extent to which the kickdown valve is depressed is an operating input for the transmission, and is discussed below.)

It is possible that the operating lever shaft could bind in the bearing inside the selector lever shaft, causing the two shafts to move together. In this way the gearshift linkage could move the throttle linkage. If this were to occur and the transmission was shifted from park into any other gear, the shift lever on the transmission would act to close the throttle valve. If the transmission was shifted from drive into neutral, reverse, or park, the shift lever on the transmission would act to open the throttle plate.

Two designs have been used for the operating lever for the kickdown valve. In 1983 and earlier transmissions the lever was held captive by the kickdown valve, as shown in Figure 5-4, while in 1984 and later transmissions the lever pushes on the end of the kickdown valve, also shown in Figure 5-4, and the two are not secured together.

Transmission Activates Linkage

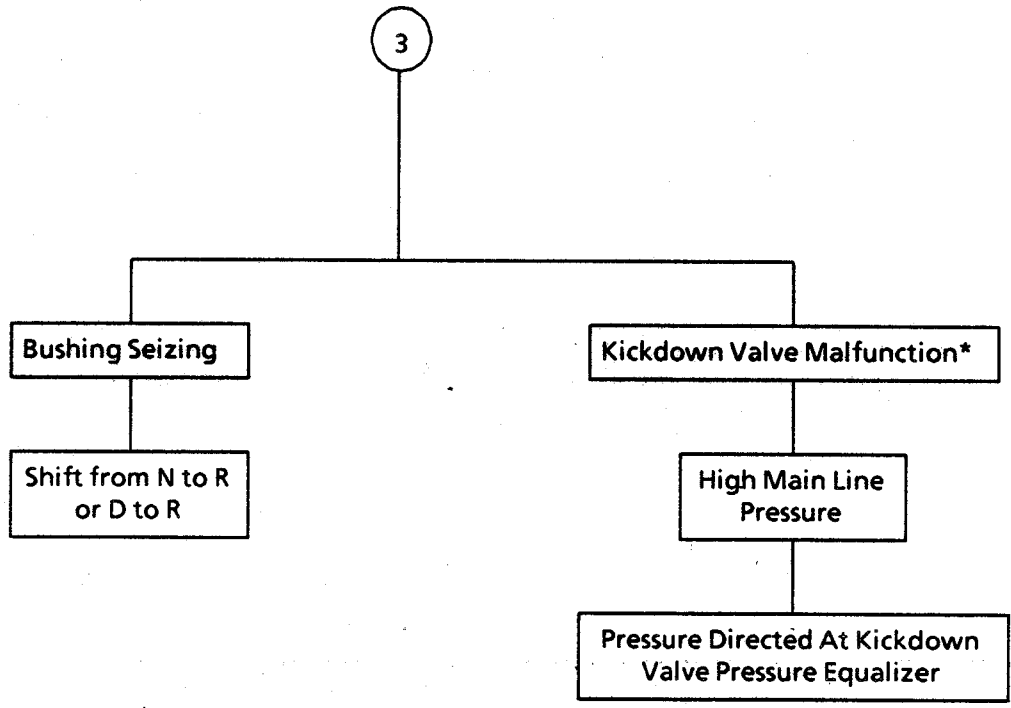

*Does not apply to transmissions from 1984 to 1987

FIGURE 5-1. FAULT TREE ANALYSIS: TRANSMISSION

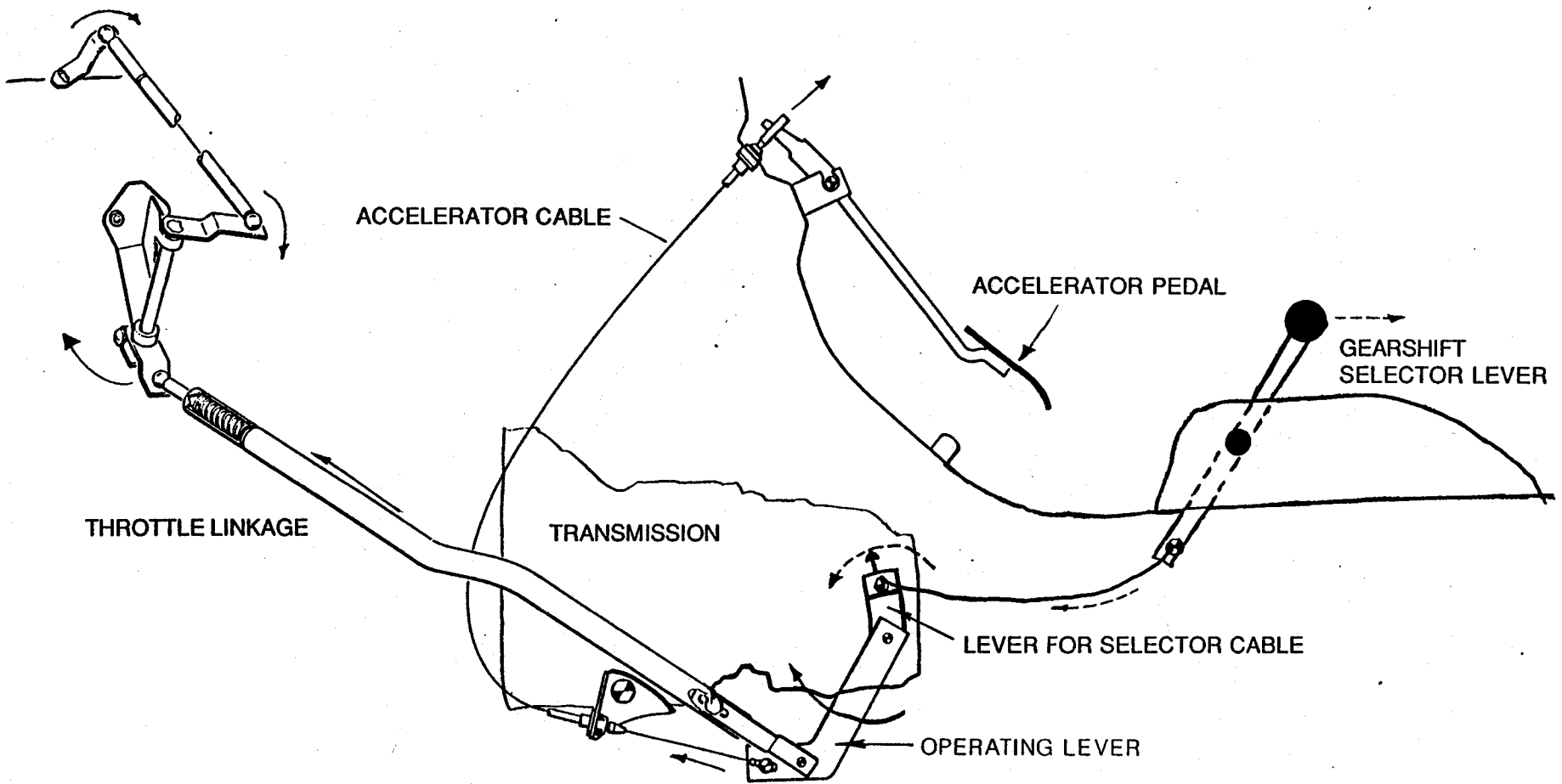

SOURCE: Derived from Official Factory Repair Manual 1983, 37.3.

FIGURE 5-2. SCHEMATIC OF THROTTLE LINKAGE AND TRANSMISSION GEARSHIFT LINKAGE

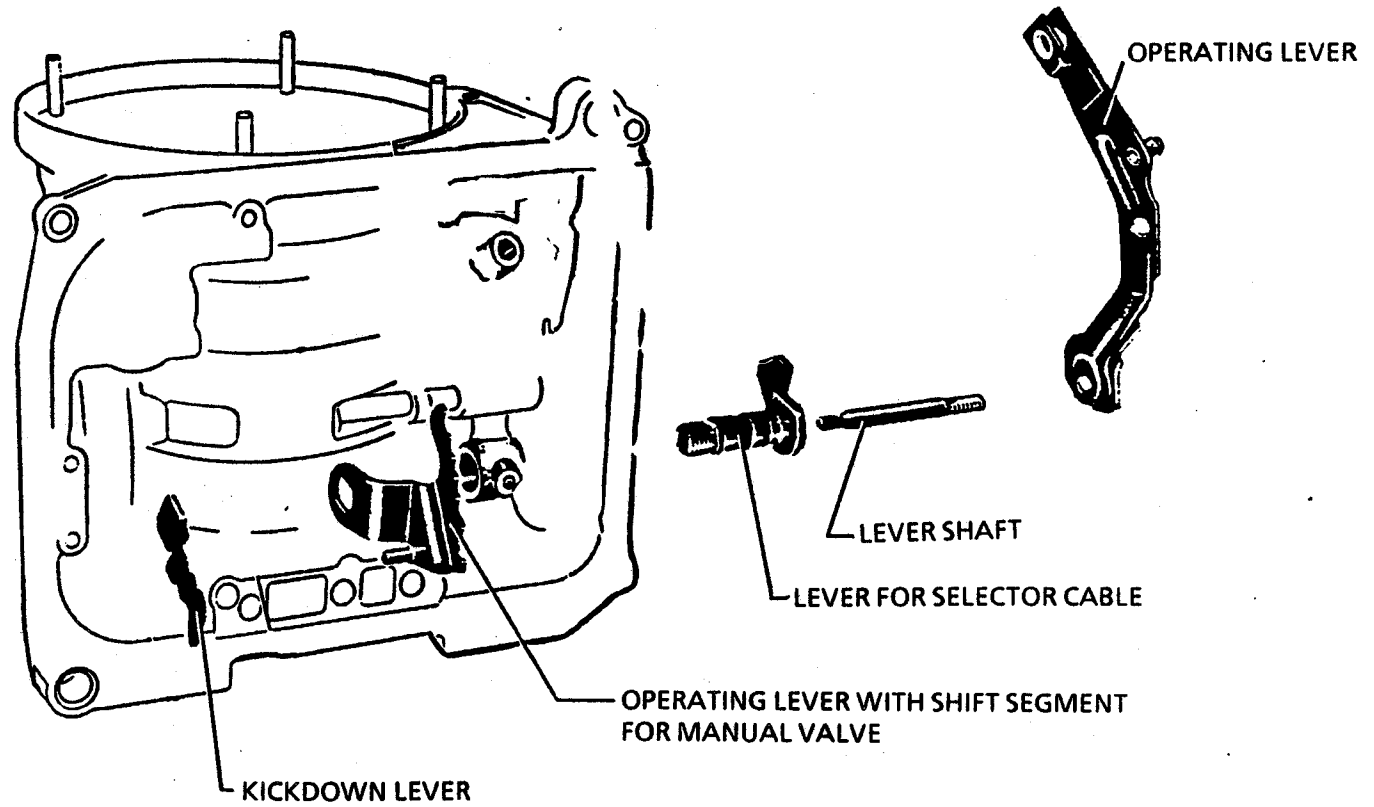

SOURCE: Derived from Official Factory Repair Manual 1983, 38.33.

FIGURE 5-3. SELECTOR LEVER, SELECTOR SHAFT, OPERATING LEVER

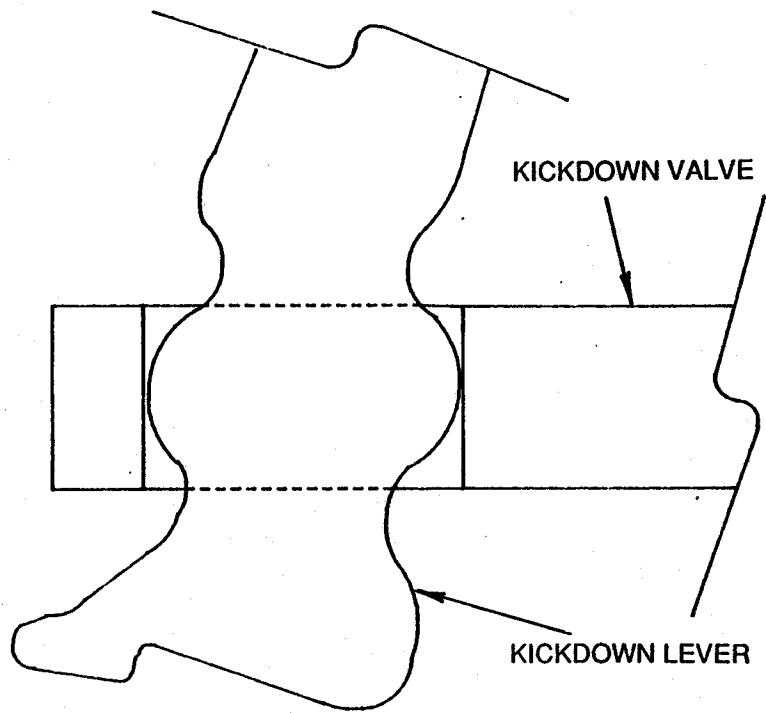

PRE-1984

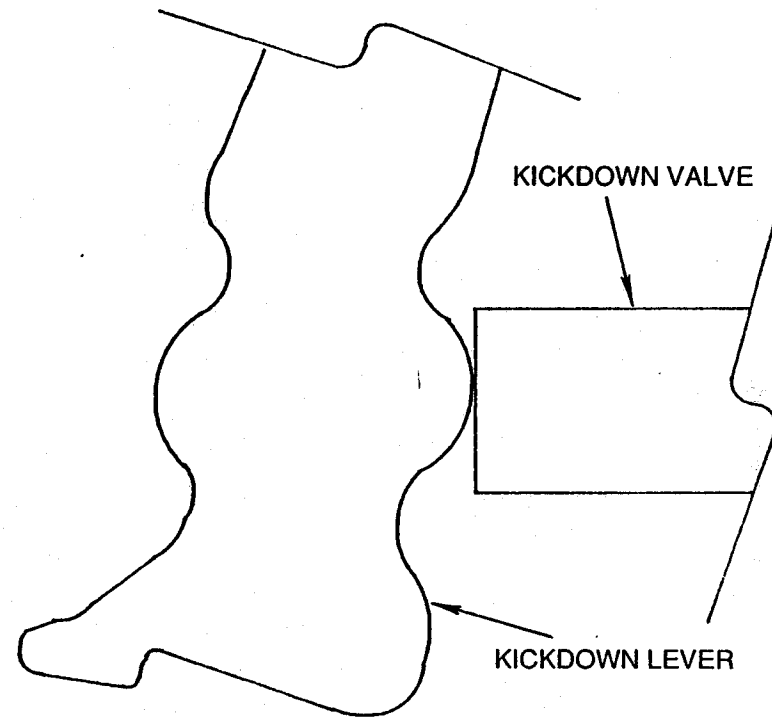

1984 - PRESENT

FIGURE 5-4. OPERATING LEVER FOR KICKDOWN VALVE

For cars equipped with 1983 and earlier transmissions, it is possible for the kickdown valve to pull on the kickdown operating lever, rotating the shaft and the accelerator linkage operating lever on the outside of the transmission which, in turn, through the accelerator linkage, would open the throttle plate. In order for this to happen the kickdown valve would have to malfunction and pull itself in. The operation of the kickdown valve is discussed in the following section.

5.3 AUTOMATIC TRANSMISSION

The automatic transmission in the Audi 5000 automobile is comprised of a torque converter and two sets of planetary gears. The torque converter provides a fluid coupling between the output shaft of the engine and the input shaft of the transmission. The input shaft of the transmission is linked to the output shaft by the two planetary gear sets which are capable of producing three forward gears and one reverse gear. These planetary gear sets can be engaged in various combinations by three clutches and one band which, in turn, are engaged or disengaged to produce the appropriate gear by a 'hydraulic logic' unit called a valve body.

The operation of the transmission is controlled by the valve body. There are three inputs to the valve body: the manual valve position, the governor line pressure, and the kickdown valve position. The position of the manual valve is controlled by the shift lever, the governor line pressure is controlled by the speed of the output shaft of the transmission, and the kickdown valve position is controlled by the throttle angle. The manual valve forces the transmission into the gear selected by moving the shift lever to the appropriate position. The kickdown valve in conjunction with the governor controls the speed at which the transmission shifts and the pressure that is applied to the bands and clutches. When the kickdown valve is fully depressed and the manual valve is in the 'drive' position, the transmission will downshift, either from 3rd gear to 2nd gear or from 2nd gear to 1st. The transmission may also downshift from 3rd to 1st gear.

The valve body assembly is comprised of three subassemblies: the transfer plate, the separation plate, and the valve body. The transfer plate contains pressure channels that allow the various pressures to act on the valves in the valve body. The separation plate determines which pressure channels in the transfer plate are connected to the different pressure channels of the valve body. The valve body sub-assembly contains the valves that control the operation of the transmission and some additional pressure channels. Figure 5-5 shows the orientation of the valve body, separation plate, and the transfer plate.

5.4 DESCRIPTION OF KICKDOWN VALVE CIRCUIT

Figure 5-6 shows a simplified schematic diagram of the fluid circuit in the valve body that contains the kickdown valve. There are five valves included in the circuit with the kickdown valve: the throttle limit valve (T.V. limit), the throttle valve, the line bias valve, the pressure regulator valve, and the kickdown valve. This diagram is a simplified model that shows the valves that affect and are affected by the kickdown valve when the manual valve is in the 'drive' or 'reverse' position. In these positions, the valves normally function in the following fashion:

The T.V. limit valve decreases the line pressure to the T.V. feed pressure. The T.V. feed pressure is 85 psi if the line pressure is greater than 85 psi, and the T.V. pressure is equal to the line pressure if the line pressure is less than 85 psi. Based on the throttle angle and the T.V. feed pressure, the throttle valve adjusts the T.V. pressure. The T.V. pressure increases with increasing throttle angle, from 5 psi up to the T.V. feed pressure for a maximum T.V. pressure of 85 psi. (The T.V. pressure and the governor line pressure act on the 1-2 and 2-3 shift valves, determining 1-2 shifts and 2-3 shifts, respectively.)

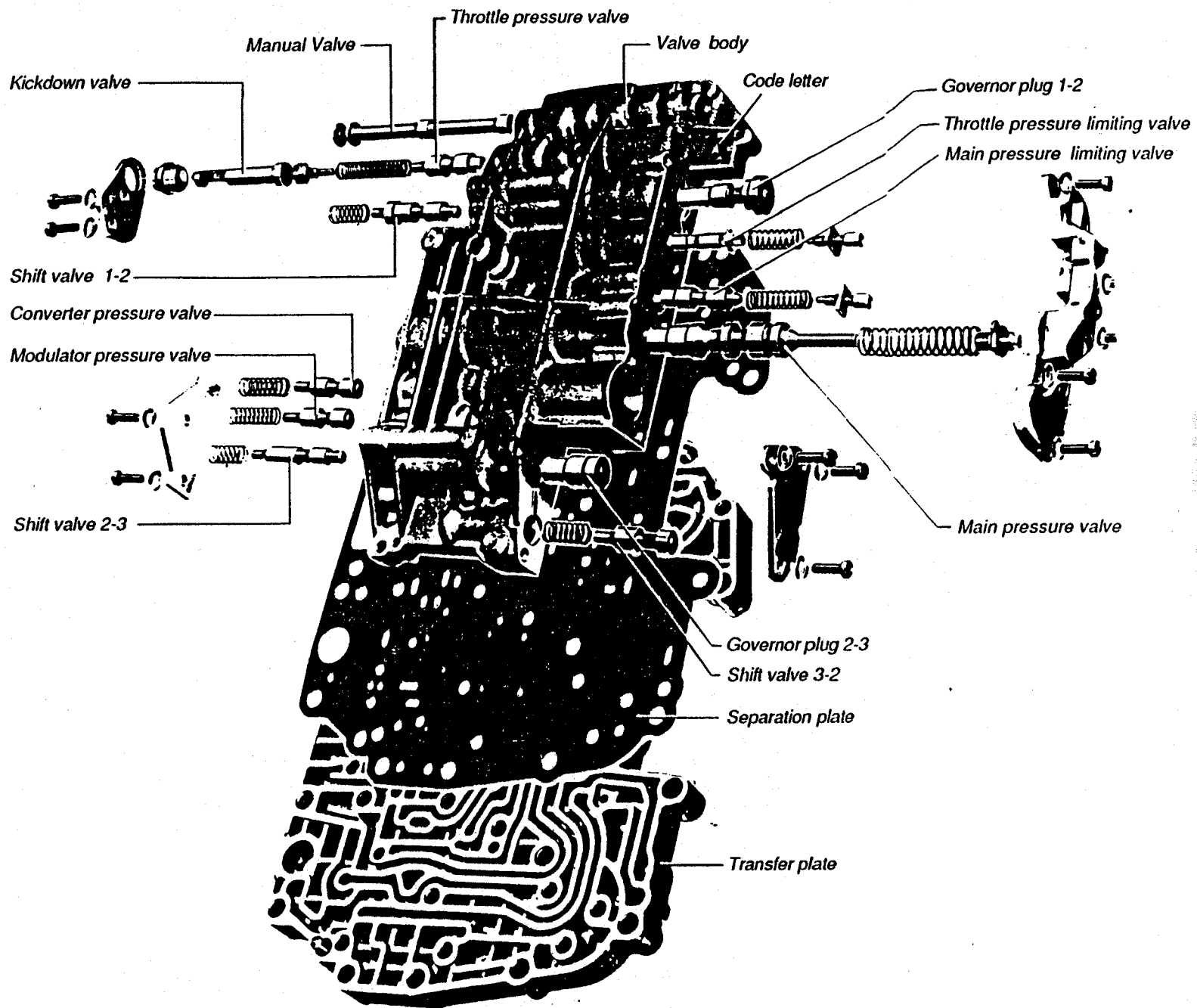

SOURCE: Automatic Transmission for Volkswagen and Audi 1974, 40.

FIGURE 5-5. TYPICAL AUDI 5000 VALVE BODY

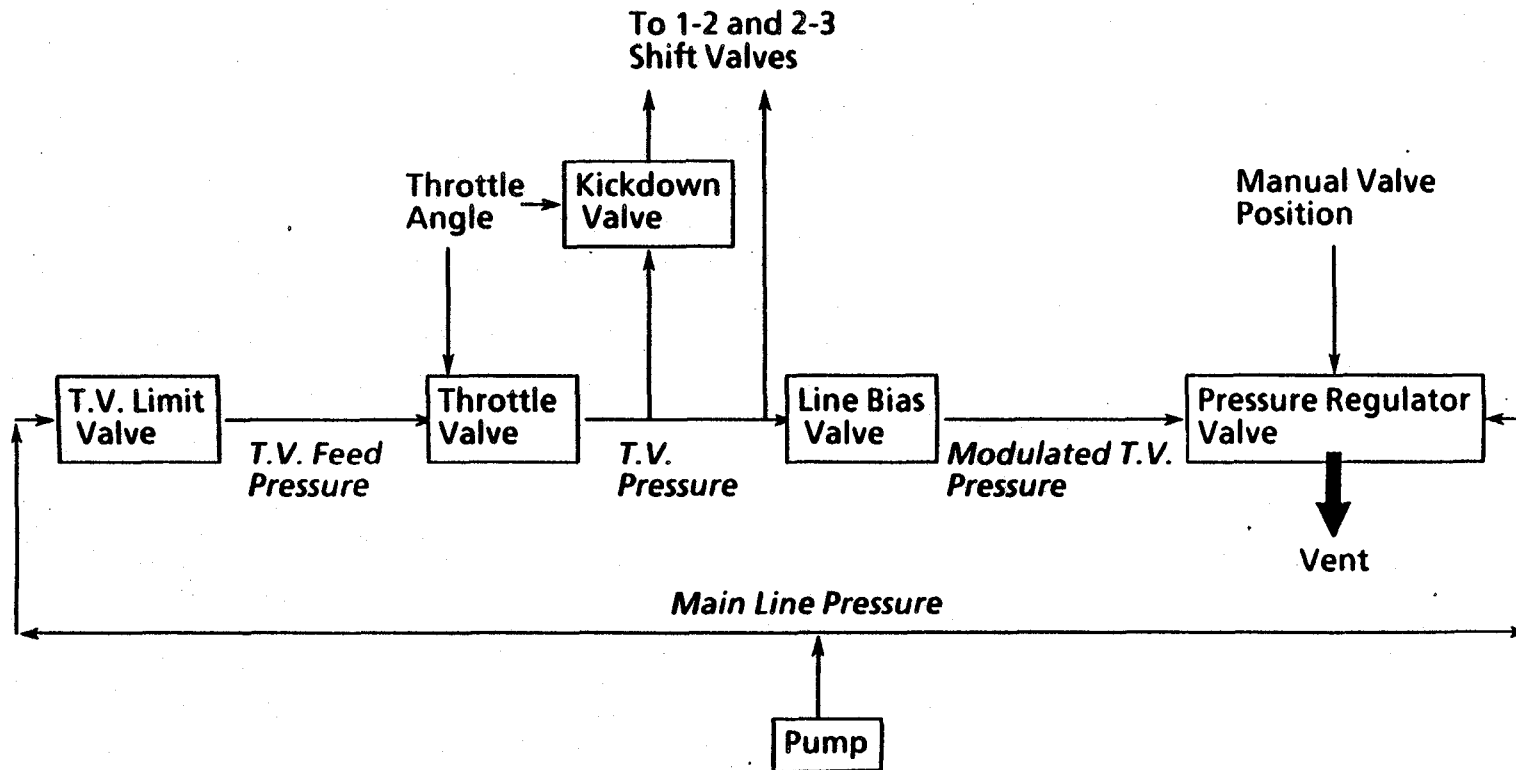

FIGURE 5-6. 1982 MODEL TRANSMISSION KICKDOWN VALVE CIRCUIT

The T.V. pressure acts on the line bias valve to produce the modulated T.V. pressure. The modulated T.V. pressure is limited to a maximum of 30 psi by the line bias valve.

The modulated T.V. pressure and the manual valve position act on the pressure regulator valve, which produces the line pressure. In effect, the pressure regulator valve increases line pressure as the throttle plate angle increases, through the actions of the throttle valve and the line bias valve. The pressure regulator valve also acts to limit the line pressure. This is the only valve in the circuit that behaves differently in reverse than in drive. In reverse, the main line pressure is limited to 300 psi, while in drive it is limited to 130 psi.

The kickdown valve forces the transmission to downshift when the throttle plate is wide open. If the transmission is in 2nd, it will downshift to 1st, and if the transmission is in 3rd gear, it will downshift into either 2nd or 1st, depending upon the speed of the vehicle. T.V. pressure and governor line pressure act on the 1-2 and 2-3 shift valves, which determine when the transmission shifts. When the kickdown valve is fully depressed, it allows T.V. pressure to act on a separate section of these valves, causing the downshift.

Figure 5-7 shows a simplified schematic of the fluid circuit in the valve body containing the kickdown valve, from a 1974 transmission which is basically the same as the 1978 model. The valves in this valve body have nearly identical functions as the valves in the 1982 valve body (the schematic of which is shown in Figure 5-4), but are placed in a different order in the fluid circuit. The only difference is that the T.V. limit valve is placed after the throttle valve, rather than before it as in the 1982 valve body. This means that the function of the T.V. limit valve is different, and that it acts as a relief valve allowing fluid to escape whenever the pressure exceeds 85 psi. Under normal operating conditions, this has no effect on the operation of the transmission. It should be noted that it is likely that similar kinds of variations probably exist for the same model transmissions made at different times, and that these variations may not coincide with different model years. The control arrangement used in the Audi transmission is typical of automatic transmissions on recent model cars, both domestic and imported, with the main variation perhaps being the order of the valves within the corresponding fluid circuit.

5.4.1 Kickdown Valve Operation and Failure Modes

Due to the manner in which the kickdown valve holds the kickdown lever captive in the 1983 and earlier transmissions, it is possible for the kickdown valve to operate the engine throttle by pulling on the kickdown lever. The following is a more detailed description of the kickdown valve, along with a discussion of possible failure modes and their side effects.

5.4.2 Kickdown Valve Operation

Figure 5-8 shows a detailed schematic of the fluid path in the 1982 valve body and Figure 5-9 shows an enlargement of the fluid path about the kickdown valve and the throttle valve. During normal operation, the kickdown valve is depressed by the kickdown lever and in turn presses on the throttle valve through the spring. T.V. pressure acts on the face of the kickdown valve and on the right face of the throttle valve. T.V. feed pressure acts in the chamber between the left and center faces of the throttle valve. The net pressure force acts to push the valve out against the kickdown lever, and this force increases as the throttle valve is depressed. Figure 5-10(a) shows a free body diagram of the external forces acting on the throttle valve and the kickdown valve. The T.V. feed pressure, acting in the chamber between the right and center faces of the throttle valve, exerts no net force on the valve assembly because the pressure in the chamber is the same throughout, and the area that the pressure acts on is the same on both the left and the right side of the chamber. T.V. pressure acts on both the

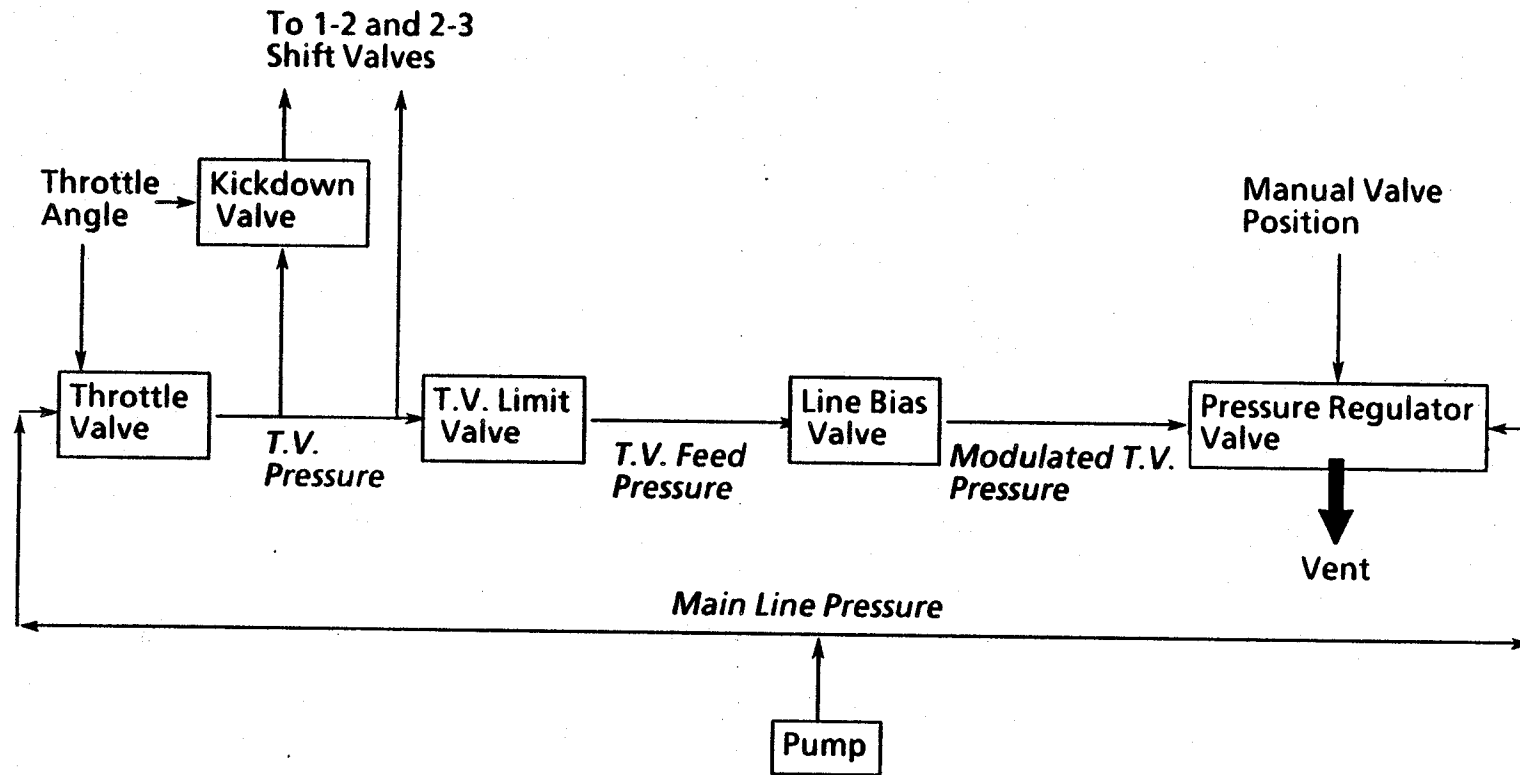

FIGURE 5-7. SIMPLIFIED SCHEMATIC OF THE 1974-82 KICKDOWN VALVE CIRCUIT

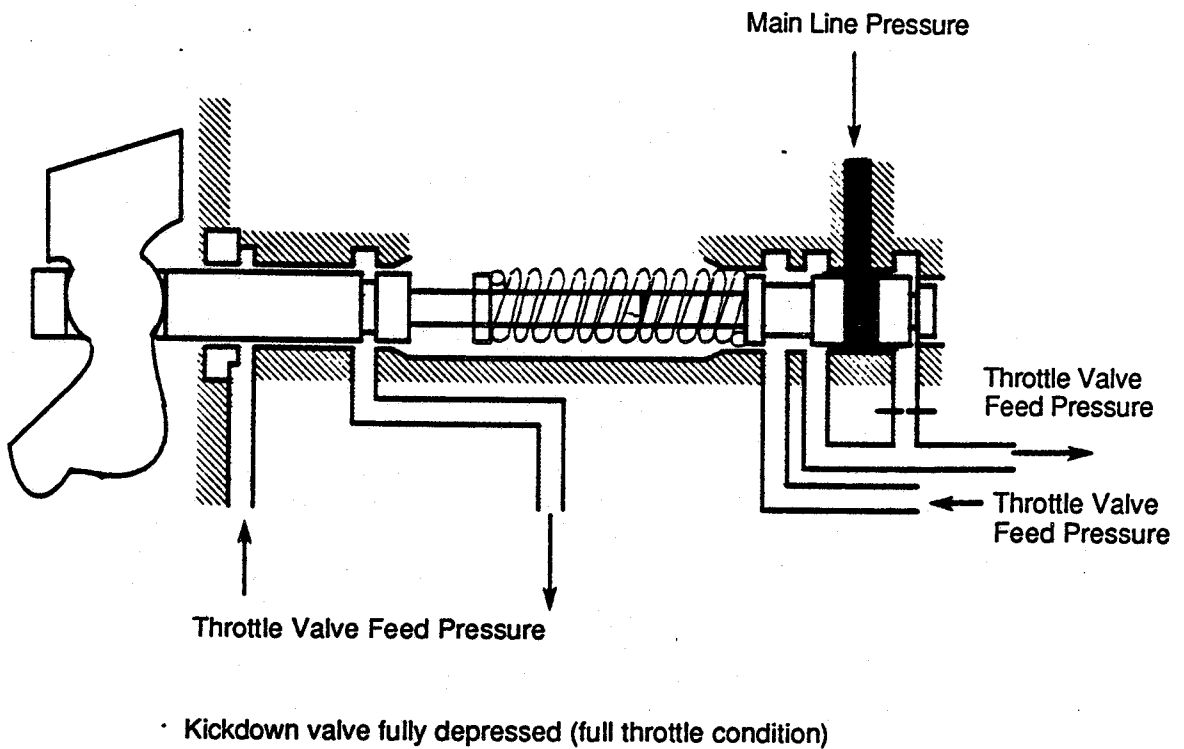
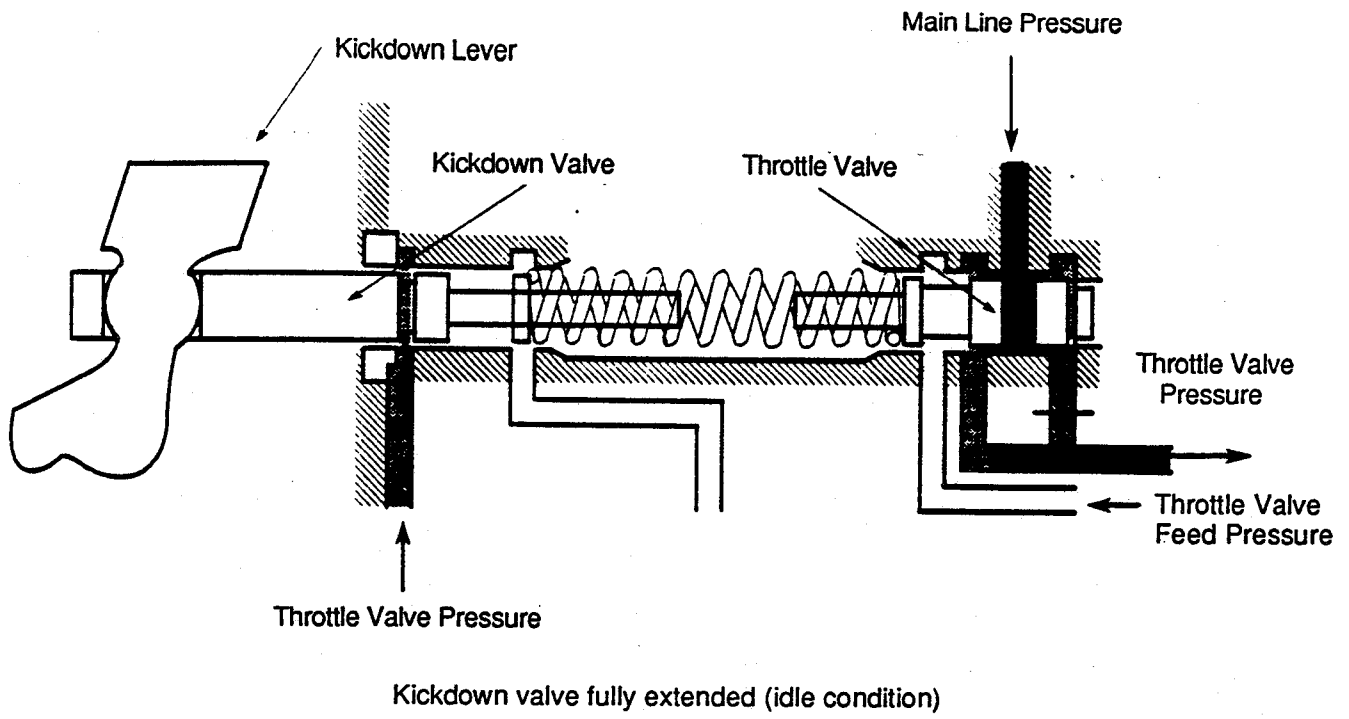

FIGURE 5-9. KICKDOWN VALVE SCHEMATIC UNDER IDLE AND FULL THROTTLE POSITION

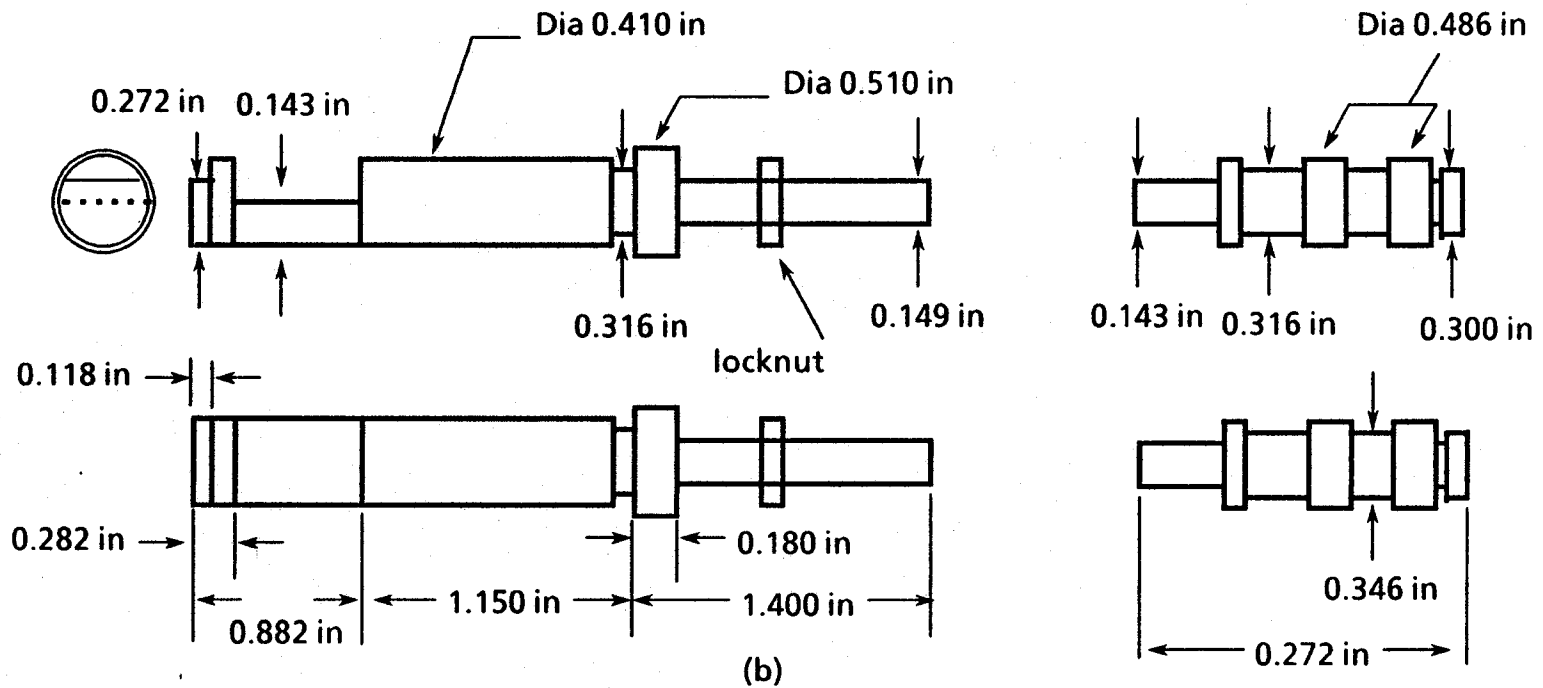
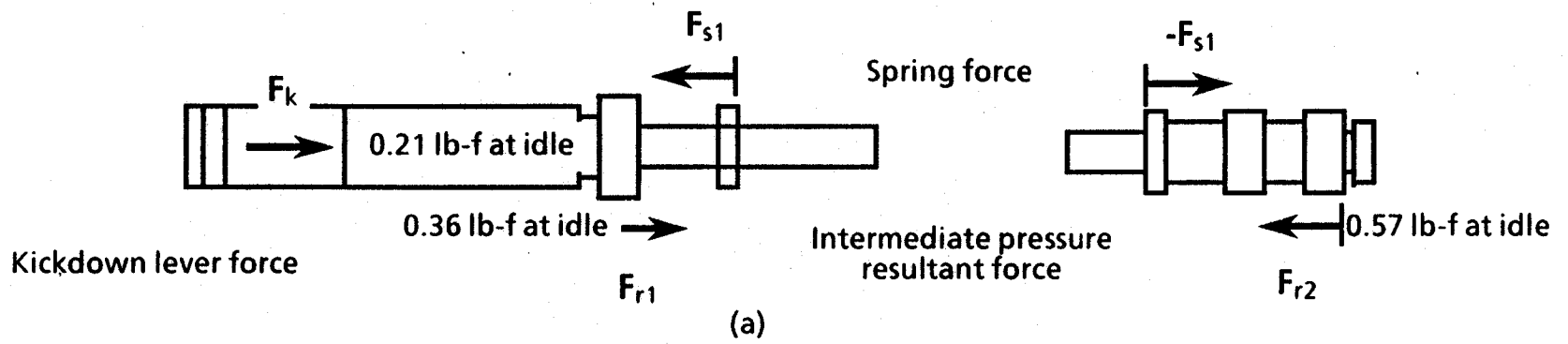

FIGURE 5-10. FREE BODY DIAGRAM AND KICKDOWN VALVE DIMENSIONS FOR A 1982 TRANSMISSION

face of the kickdown valve and the right face (in the figure) of the throttle valve, but the area that the pressure acts on is greater at the throttle valve, resulting in a net force acting to push this assembly out toward the kickdown lever. This force increases with T.V. pressure which, in turn, increases with increasing throttle angle, as described above. The net pressure force is balanced by the force exerted by the kickdown lever.

5.4.3 Failure Modes

Since the net pressure force acts to push the throttle valve outward (closing the throttle plate) under normal operating conditions, a malfunction must occur which results in the throttle valve being pulled inward. The throttle valve would have to become unable to resist the force resulting from the T.V. pressure acting on the kickdown valve. This could happen in two different ways: the throttle valve could stick in its bore, or the T.V. pressure could somehow be constricted or unable to act on the right face of the throttle valve.

5.4.4 Stuck Valve

If the throttle valve were to stick in its bore, the transmission could malfunction in several different ways. Normally, the throttle valve produces T.V. pressure based upon the engine throttle opening. With the valve stuck in its bore, however, this pressure would no longer be dependent upon the throttle opening. (T.V. pressure is used by the shift valves to determine when the transmission shifts, and is used by the line bias and pressure regulator valves to determine line pressure.)

TSC has calculated that if the throttle valve was stuck in a position corresponding to its idle or near-idle position, T.V. pressure would be 5 psi, and the kickdown valve would be pulled in 0.028 in (5 psi acting on 0.072 sq in producing 0.36 lb-f, which would depress the spring between the throttle and kickdown valve, which has a stiffness of 12.7 lb/in by 0.028 in). As a result, the gear changes would occur at inappropriate times and the line pressure would remain independent of throttle position at 85 psi in drive or 140 psi in reverse. This would allow the clutches to slip if the car accelerated.

5.4.5 Inappropriate Pressure Applied to Kickdown Valve

The pressure required to depress the kickdown valve fully can be calculated based on the dimensions of the valve and the stiffness of the spring. The distance the spring travels from a relaxed to fully compressed position is 0.665 in; the spring stiffness is 12.7 lb/in. Figure 5-10(b) shows a dimensioned drawing of the kickdown valve. It takes 117 psi of pressure acting on 0.072 sq in to compress a 12.7 lb/in spring for 0.665 in. This pressure is the minimum necessary to depress the kickdown valve. It does not include the added resistance due to the external linkage, as the actual pressure necessary would be greater. During normal operating conditions, the pressure acting on the face of the kickdown valve never exceeds 85 psi. Figure 5-11 shows the pressure variations acting on the face of the kickdown valve, with T.V. pressure as a function of throttle angle depression, for both reverse and drive with the transmission engaged in 1st gear. This figure applies to both valve bodies discussed in the previous section. At idle, 5 psi acts on the face of the throttle valve while at wide-open throttle, 85 psi acts on the face of the valve.

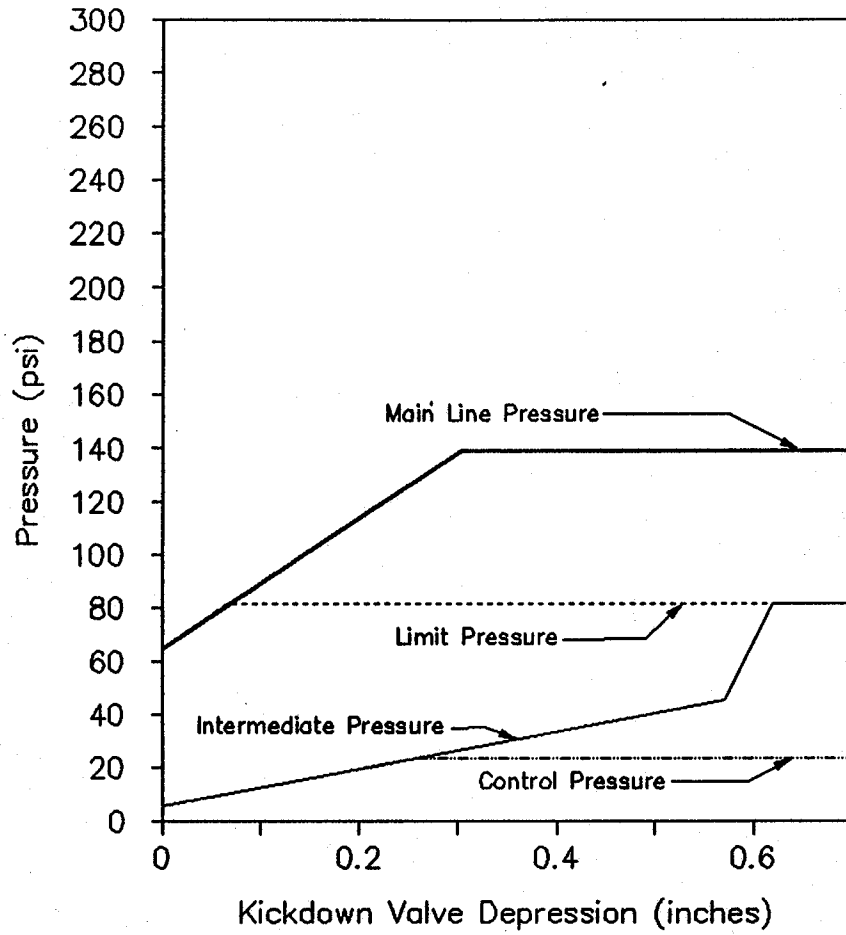

Drive (1st Gear)

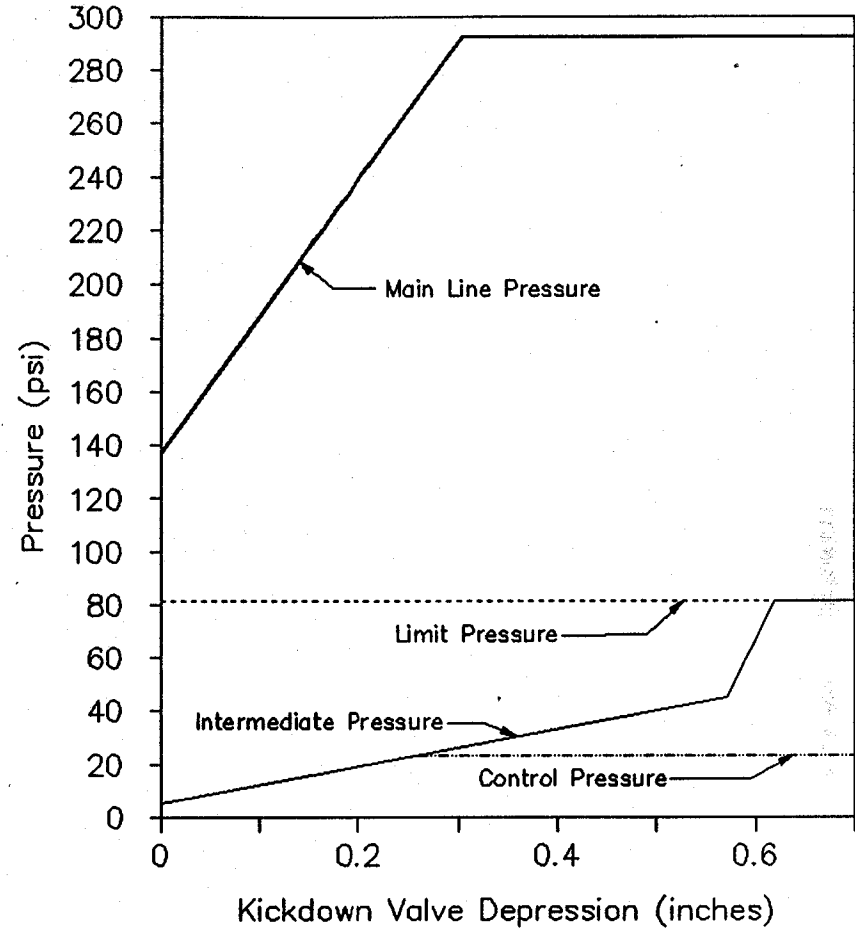

Reverse

SOURCE: Based on VWOA information from ODI.

FIGURE 5-11. KICKDOWN VALVE DEPRESSION/PRESSURE IN DRIVE AND REVERSE

Two types of failures within the valve body of the transmission could result in pressure exceeding 117 psi being applied to the face of the kickdown valve. A leak between channels could either cause line pressure to enter directly into the T.V. pressure channel, or cause a valve to function in an unintended fashion. In addition, it is possible for the pressure to increase at the face of the kickdown valve if one or more other valves in the valve body fail, allowing either line pressure directly into the T.V. pressure channel or a pressure change in another channel. Some combination of these two types of failures may also result in this increase in pressure. In all such cases, the throttle valve would have to be stuck in its bore or the T.V. pressure restricted from acting on the right face of the throttle valve.

Because of the size of the pressure channels in the transfer plate and valve body (ranging from approximately 0.100 to 0.310 in wide and 0.170 to 0.555 in deep), it would be difficult for a blockage to occur. If sufficient debris were able to accumulate, there would either be some evidence when the transmission was disassembled, or other difficulties within the transmission, such as stuck valves would be detected. Furthermore, if a constriction or blockage of T.V. pressure to the throttle valve were to occur, it would be more likely to take place in the separation plate. The feed hole to the throttle valve in the separation plate has a diameter of 0.087 in, and is more easily constricted than a pressure channel.

If T.V. pressure were not allowed to act on the right face of the throttle valve, an unstable situation would result. With no T.V. pressure to balance the spring force, the throttle valve would move to the right, allowing T.V. limit pressure into the T.V. pressure channel. This would cause the kickdown valve to displace 0.211 in, which would open the throttle approximately 31 percent in 1983 and earlier models. In addition, the line pressure would increase to its maximum (130 psi in drive, 300 psi in reverse), and the gear shifts would occur at inappropriate times.

5.5 CONCLUSIONS

In the Audi 5000 from 1978 through 1983, the transmission could conceivably activate the linkage and throttle plate in a shift from drive into neutral, reverse, or park. In these models, the throttle plate could be opened by an unbalanced pressure of at least 117 psi on the kickdown valve. An SAI due to transmission activation of the throttle would require multiple failures, would be irreversible, and would be easily detected after the fact. No evidence of such failures was found in vehicles exhibiting SAIs by TSC or ODI investigators.

6. BRAKE SYSTEM

6.1 INTRODUCTION

After the onset of an SAI, the driver should be able to stop the vehicle by braking. Drivers of Audi 5000s involved in sudden acceleration report that the brake pedal was depressed but the vehicle did not stop. On the assumption that the drivers had properly applied the brakes, the brake system was evaluated to identify any system malfunction which would prevent the driver from stopping the car. Appendix C supplies mathematical justification of the discussion to follow.

6.2 SYSTEM DESCRIPTION AND CHARACTERISTICS

The standard brake system on all Audi 5000s built after 1983 is a hydraulic disk brake system with a hydraulic power assist. The disk brake system consists of a master cylinder, hydraulic power assist, rear-brake pressure regulator, brake fluid lines, and four caliper brake assemblies. The hydraulic power assist consists of a central hydraulic pump, brake and steering fluid reservoir, a servo unit, and a hydraulic fluid accumulator. The hydraulic power assist reduces the amount of force the driver must apply to the brake pedal to decelerate the car. (Prior to 1984, a vacuum assist was used.) As shown in Figure 6-1, the pedal force required to produce 0.3 g of deceleration is 22.5 lb-f (100 N) with the power assist and 90 lb-f (400 N) without the power assist. The pedal forces required to hold an Audi stationary with a fully open idle stabilizer would be considerably smaller since it produces 0.3 g acceleration for only an instant.

Pressure in the power-assist system is developed in the central hydraulic pump, a constant displacement, eight-piston pump with two independent hydraulic circuits. Power steering is supplied by six of the pistons; fluid for the brake hydraulic assist is supplied by two pistons. The power steering and brake circuits are both supplied with hydraulic fluid from the same reservoir. The pump has a pressure-relief valve that bypasses the braking circuit when the pressure exceeds 155 bars. VWOA specifies that the valve should be replaced when it opens below 145 bars. Pumps are replaced when the flow rate is below 5 cc/sec at an engine speed of 850 RPM.

The pressure accumulator is a device which stores the pressurized hydraulic fluid to be used by the servo assist. The central hydraulic pump restores the fluid level and pressure in the accumulator. Without pump operation, enough fluid is stored in the accumulator for about 29 moderate brake applications that produce 0.22 g deceleration each. Each time the brake pedal is depressed, the servo assist draws pressurized fluid from the accumulator. Pumping the brake pedal requires a large volume of fluid. A pedal displacement of 0.79 in (20.1 mm) removes 0.27 in³ (4.5 cm³) of fluid from the accumulator and produces 0.20 bar (and produces about 0.22 g deceleration) of brake pressure. The servo assist uses this fluid during braking and then passes it at low pressure to the reservoir. A pressure-relief valve in the accumulator is designed to open at 150 bars when installed, and is replaced when it opens below 140 bars. The pump delivers fluid to the accumulator as long as pressure developed by the pump is greater than the pressure in the accumulator. When the fluid in the accumulator reaches full pressure, the relief valve operates continuously until pressure drops below designed accumulator pressure, allowing the hydraulic fluid delivered by the pump to drain to the reservoir.

Loading time of the accumulator is defined as the amount of time required to raise the pressure in the accumulator from the empty pressure to any specified pressure. The empty pressure is the accumulator gas pressure when there is no hydraulic fluid present in the accumulator. Test data in Figure 6-2, supplied by Audi, show the relationship between gas pressure versus time during loading of the accumulator from empty pressures of 30 and 80 bars. For these test results, it took 19 seconds to load the accumulator from 80 to 144 bars, and 36 seconds to load it from 30 to 144 bars.

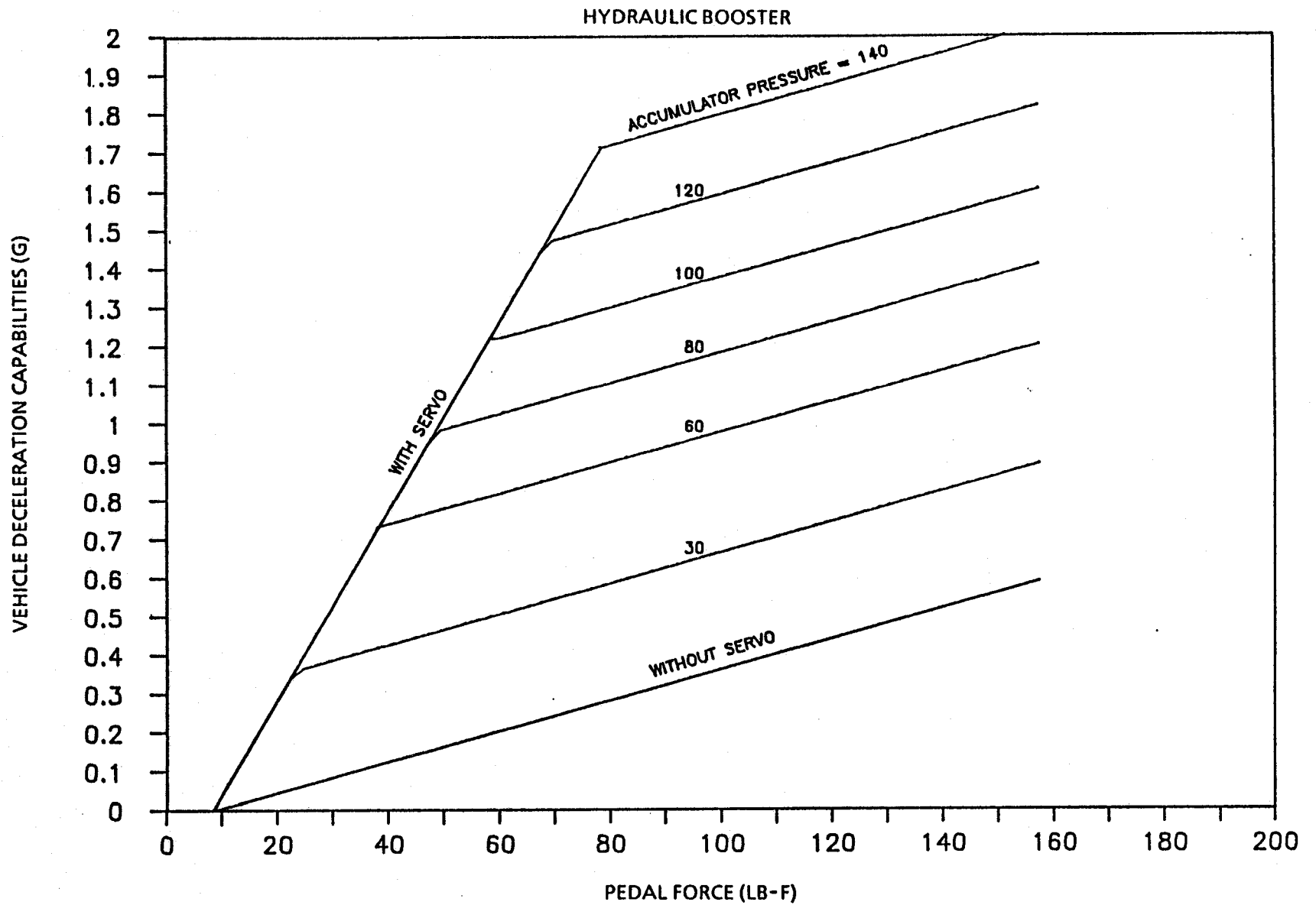

SOURCE: Calculated by TSC based on VWOA data from ODI.

FIGURE 6-1. VEHICLE DECELERATION VERSUS PEDAL FORCE

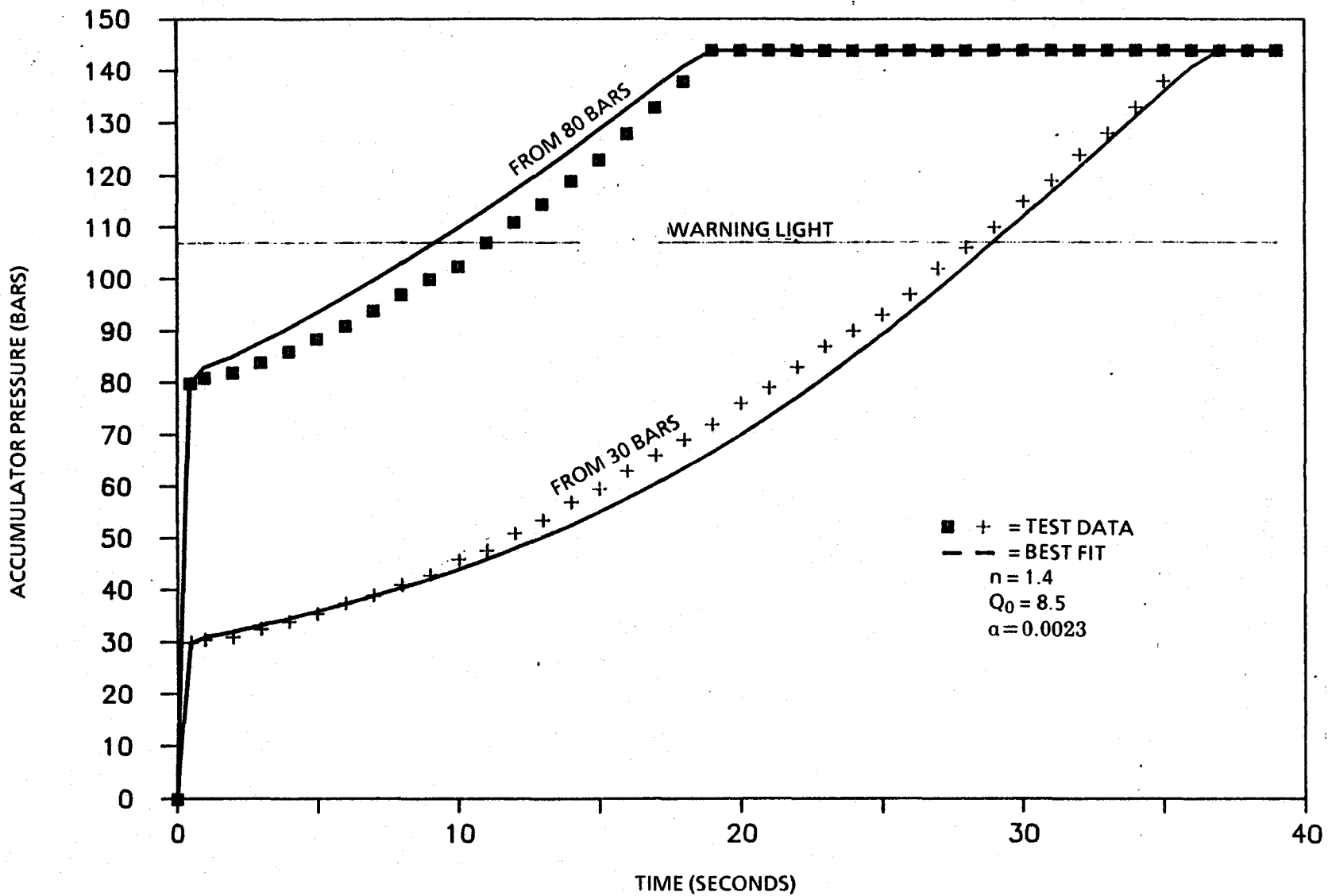

SOURCE: Calculated by TSC based on VWOA data from ODI.

FIGURE 6-2. LOADING TIME FOR BRAKE ACCUMULATOR

6.3 POSSIBLE MALFUNCTIONS

After the onset of an SAI, the driver should be able to control the vehicle by braking. The severity of the event depends on the driver's reaction and the brake system's condition. A total brake system failure would be obvious after an incident. In order for the system to completely fail, the hydraulic brake fluid must leak internally to the master cylinder or leak into the environment. In such a closed hydraulic system, evidence of a failure would remain. A low fluid level in the brake fluid reservoir would indicate a leak somewhere in the system. When the master cylinder leaks internally, the failure is almost always permanent and the brake system continues to be inoperable after the incident.

The brake system is capable of a temporary malfunction of the hydraulic power assist. If the power-assist system malfunctioned, the required brake-pedal pressure would be about 4.6 times the normal (assist working) required braking force. Though this would make the system seemingly unresponsive, it could, with enough force, still stop the vehicle.

6.4 HYDRAULIC ASSIST MALFUNCTION AND RECOVERY

A temporary failure of the hydraulic assist is possible. If the brake accumulator was drained fully on start-up and the driver immediately shifted the vehicle into gear and pumped the brake pedal faster than the central hydraulic pump could restore accumulator pressure, the assist would be inoperable (degraded). However, given time, the pump would restore the fluid level and pressure in the accumulator and the brake-assist system would operate normally.

6.5 EFFECTS OF A DRIVER OUTRACING THE HYDRAULIC PUMP

Drivers who have experienced sudden acceleration claim that the brake was inoperable during the incident but operated normally after the incident. During the incident, the driver can brake the car by depressing the brake continuously, or by rapidly pumping the brake pedal. Pumping the brake could decrease the braking effectiveness with every pedal stroke. For this to occur, the volume of fluid being used by the servo must be greater than the fluid delivered by the pump. Eventually the volume of fluid stored in the accumulator would decrease until the accumulator was empty, causing the power assist to become ineffective. To determine both the number of pedal strokes and the amount of time needed to produce this effect, it was assumed that the driver applied an average force of 100 lb-f to the brake pedal and depressed the brake pedal once every second. The pump delivery rate depends on the engine speed. The worse case for the pump would be at idle (850 RPM) for the lowest hydraulic fluid flow rate. The amount of fluid stored in the accumulator is related to the initial gas pressure. The lower the initial accumulator gas pressure, the more hydraulic fluid can be stored. A typical accumulator gas pressure is between 30 and 80 bars; the accumulator should be replaced when the gas pressure is below 30 bars. For an initial gas pressure of 80 bars with the engine at 850 RPM, it would take 18 seconds and 18 pedal depressions to drain a fully loaded accumulator.

After the accumulator is drained, brake effectiveness can be reduced depending on how much of each second is used in the motion of the pedal and how much is used to hold the pedal depressed. When the pedal is in motion, fluid is drawn from the accumulator; when the pedal is held stationary, fluid pressure builds in the accumulator. When the accumulator oscillates between fully drained and partially filled, theoretical brake deceleration capabilities can oscillate between 1.3 and 0.36 g. This would make the brakes feel operative during one depression and inoperative in the next, and would continue with each pedal depression. When the initial gas pressure of the accumulator is 30 bars, it takes over 60 seconds and 60 pedal depressions to get to the oscillation state. In these cases the engine speed is 850 RPM. If the engine RPM exceeds 1000, the volume of fluid being used by the servo is less than the fluid delivered, making it very difficult to outrace the hydraulic pump. In the case of a sudden acceleration, the engine must produce enough power to move the vehicle, and would most likely maintain an engine speed greater than 1000 RPM.

To outrace the pump, the driver would have to maintain a pedal-pumping rate of greater than two times per second with an average force of 100 lb-f for longer than 18 seconds. Pumping at this rate would provide a severe deceleration until the accumulator was depleted. However, even with the accumulator depleted, the application of this much force would stop the vehicle.

7. DIMENSIONS, SPECIFICATIONS, AND FORCES RELATIVE TO THE AUDI DRIVING ENVIRONMENT

7.1 OBJECTIVE AND APPROACH

The overall objective of this section is to identify driver-related factors that may contribute to or cause driver errors and thereby produce SAIs. Two categories of driver-related factors are examined:

- the physical arrangement of the Audi driving compartment, including seats and pedals
- the characteristics which discriminate the Audi driver (especially those included in NHTSA's sudden acceleration complaint file) from drivers in general

In this section statistical comparisons are made between physical measurements of the Audi driver's environment and measurements of the U.S. passenger car fleet, and between the characteristics of the Audi driver and nondifferentiated U.S. drivers. Correlations are on a fleet basis.

The Audi driving environment examined includes both the seating dimensions and the pedal arrangements, measurements, and forces. Driver comparisons are made on the basis of age, sex, height, income, accident record, experience, and exposure (i.e., vehicle miles of travel per time unit). These comparisons rely extensively on available dimensional data from vehicle manufacturers, information provided by Audi, TSC measurements, two accident databases (the National Accident Sampling System [NASS] and the Crash Avoidance Research Data File [CARDfile]), and survey data from the National Personal Transportation Study (NPTS).

7.2 THE AUDI DRIVING ENVIRONMENT

It can be hypothesized that a particular vehicle may have a relatively high frequency of reported errors for new drivers because the vehicle has a physical driving configuration which is substantially different from previously driven vehicles. Studies by NHTSA (Perel 1983) and TSC (Hoxie 1984) have indicated that driver unfamiliarity with a vehicle substantially increases the probability of accidents. As noted below, the Audi 5000's SAIs occur early in the ownership cycle. In order to explore whether drivers may have found the Audi's driving configuration unfamiliar, thereby increasing the likelihood of errors, comparisons were made between the Audi 5000 and other vehicles' dimensions, specifications, and forces relating to the seating and pedal arrangements.

Dimensions used for the seating comparisons are derived from the Society of Automotive Engineers Recommended Practice J1100, Motor Vehicle Dimensions. This practice defines a uniform set of interior and exterior dimensions for passenger cars. All dimensions are defined normal to a three-dimensional reference system. Each dimension is assigned an alphanumeric code which is composed of a prefix letter denoting the direction (W - width, H - height, and L - length) and a sequence number. J1100 defines each of these dimensions and how they are to be measured. The interior measurements of interest here are defined with the adjustable front seat in its rearmost normal driving position resulting in the H-point (pivot center for the torso and thigh) being positioned at the seating reference point (SgRP). This SgRP is usually one notch forward from the most rearward position. The manufacturer uses either an H-point machine (a three-dimensional stick-like dummy) or a two-dimensional drafting template. In both cases, the machine or template is set to the 95th percentile leg segments as specified in SAE Recommended Practice J826b. Dimensional comparisons, therefore, are based on the same criteria.

TSC has available, in a computerized database, complete dimensional data for all GM makes, models, and body lines from 1975 through 1983. Identical but less extensive data were also available for

approximately 5,000 domestic and imported vehicles from 1965 to 1975 and any vehicle with 10,000 or more registrations in model years 1975, 1979, or 1980 (100 to 150 vehicles per model year). Identical data were provided by Audi for their 5000 model in two sets: 1978 through 1983 and 1984 through 1986.

TSC determined the means, standard deviations, and maximum and minimum values for the available dimensional data, and compared them to the same measurements provided by Audi. These comparisons were made using the "T" value, which is the dimension from the Audi (or similar vehicle) minus the mean of the same measurement from the data set to which the Audi is being compared, divided by its standard deviation.

In addition to the aggregated dimensions of the U.S. fleet, the Audi dimensions were compared to those of three 1983 Cadillac models whose dimensions were available in the TSC database. These vehicles were three 1983 Cadillac models selected under the assumption that they would be purchased by buyers from the same economic strata and could represent the type of vehicle the Audi purchasers may be accustomed to driving.

Table 7-1 shows comparisons for the data describing the two Audi models with GM aggregated dimensional data and data for the three Cadillac models (the Cimarron, a small, front-wheel-drive "European-type" road car based on the J-body line; the Eldorado, a front-wheel-drive luxury coupe; and the DeVille, a large, rear-wheel-drive luxury sedan).

In the T tables (Figures 7-1 and 7-2), the two Audi model-year groups and three Cadillacs are compared to all GM models. (These GM models represent approximately 50 percent of the automobiles on the road in the U.S.)

The T values show that of the 25 seating attributes that were compared, only 5 attributes of the 1978 to 1983 Audis and 7 of the 1984 to 1986 Audis were within 1 standard deviation of the mean of all GM vehicles,* whereas 50 to 75 percent of the Cadillac seating attributes, depending on the model, were within 1 standard deviation. Six Cadillac measurements were outside of two standard deviations, whereas ten Audi measurements were three to five standard deviations from the mean. Among Cadillacs, the Cimarron is the closest to the Audi, whereas the DeVille is the farthest. The DeVille is the best fit to the overall GM data.

With respect to individual measurements:

- The seat in the Audi is much harder than in the standard GM vehicle (H32).
- The Audi floor covering is much thicker (H67).
- The Audi seat has less rise (H58) than the standard GM seat when adjusted from the rearmost seating position to the foremost. The Audi seat is significantly higher than the standard GM seat, but when moved forward to accommodate a smaller driver, the seat rises less than a standard GM seat.
- The hip angle (L42) of the 1978 to 1983 Audi is much greater than the aggregate.

Assuming the data are normally distributed, a measurement which is more than one standard deviation from the mean is either larger or smaller than 84 percent of all the measurements on which the mean is based. A measurement two standard deviations from this mean is larger or smaller than 97 percent of the cases.

TABLE 7-1. COMPARISON OF GM FLEET AND SELECTED AUDI AND CADILLAC DIMENSIONS

SAE	DIMENSION	G.M.		CADILLACS			AUDIS		T VALUES			T VALUES	
		Mean	δ	Cim	Eld	Dev	Audi 84	Audi 78	Cim	Eld	Dev	Audi 84	Audi 78
H32	Seat Cushion Deflection	83.7	9.7	102.0	78.0	81.0	30.0	47.0	1.89	-.59	-.28	-5.54	-3.78
H67	Floor Covering Thickness	14.4	6.9	16.0	8.0	6.0	37.0	37.0	.23	-.93	-1.22	3.28	3.28
H58	H-Point Rise	22.9	3.7	28.0	20.0	19.0	11.0	11.0	1.38	-.78	-1.05	-3.22	-3.22
H30	H-Point to Heel Point	219.0	23.0	256.0	217.0	232.0	291.0	255.0	1.61	-.09	.57	3.13	1.57
L17	H-Point Travel	155.4	22.4	192.0	139.0	139.0	216.0	216.0	1.63	-.73	-.73	2.71	2.71
H13	Seat Wh. to Center Thigh	93.9	10.7	72.0	91.0	70.0	66.0	30.0	-2.05	-.27	-2.23	-2.61	-5.97
H54	D-Point to Tunnel	54.1	23.5		132.0	64.0			-2.30	3.31	.42	-2.30	-2.30
L53	H-Point to Heel Point	880.0	18.4	866.0	899.0	867.0	845.0	810.0	-.76	1.03	-.71	-1.90	-3.80
L7	Steering-Wheel Torso Clearance	345.1	17.6	368.0	350.0	352.0	378.0	379.0	1.30	.28	.39	1.87	1.93
H3	Seat Chair Height	275.6	20.2	330.0	301.0	282.0	311.0	307.0	2.69	1.26	.32	1.75	1.55
W9	Steering-Wheel Diameter	385.1	9.0	399.0	394.0	394.0	400.0	400.0	1.54	.99	.99	1.66	1.66
W16	Seat Width	1156.9	327.6	512.0	1259.0	1347.0	630.0	565.0	-1.97	.31	.58	-1.61	-1.81
L14	Seat Thickness at Center	151.3	28.8	96.0	125.0	156.0	107.0	120.0	-1.92	-.91	.16	-1.54	-1.09
W7	Steering-Wheel. Cent. to Cent. Car	377.1	31.5	310.0	360.0	401.0	331.6	330.0	-2.13	-.54	.76	-1.44	-1.50
H56	D-Point to Floor	157.1	23.9	159.0	171.0	182.0	190.0	160.0	.08	.58	1.04	1.38	.12
L40	Back Angle	26.3	1.0	25.0	26.5	26.5	25.0	23.5	-1.30	.20	.20	-1.30	-2.80
L9	Seat Depth	491.7	30.2	493.0	545.0	457.0	460.0	483.0	.04	1.76	-1.15	-1.05	-.29
L52	Brake Pedal to Accelerator	81.1	29.3	62.0	62.0	57.0	52.0	37.0	-.65	-.65	-.82	-.99	-1.51
L44	Knee Angle	128.0	3.5	127.5	132.5	125.5	124.6	115.3	-.14	1.29	-.71	-.97	-3.62
L34	Max. Eff. Leg Room Accel.	1075.3	12.4	1072.0	1088.0	1067.0	1064.0	1028.0	-.27	1.02	-.67	-.91	-3.81
L42	Hip Angle	97.2	2.0	98.5	99.5	97.5	99.0	89.4	.65	1.15	-.15	.89	-3.88
W20	Center Occup. to Center Car	366.4	18.8	334.0	351.0	381.0	350.0	350.0	-1.72	-.82	.78	-.87	-.87
L13	Brake-Pedal Knee Clearance	617.0	31.7	601.0	631.0	619.0	600.0	592.0	-.50	.44	.06	-.54	-.79
L46	Foot Angle	87.6	1.6	87.0	87.0	87.0	87.0	87.0	-.38	-.38	-.38	-.38	-.38
H18	Steering-Wheel Angle Vertical			20.0	18.3	19.0	21.4	20.2					

Cim = Cadillac Cimarron
 Eld = Cadillac Eldorado
 Dev = Cadillac Coup DeVille

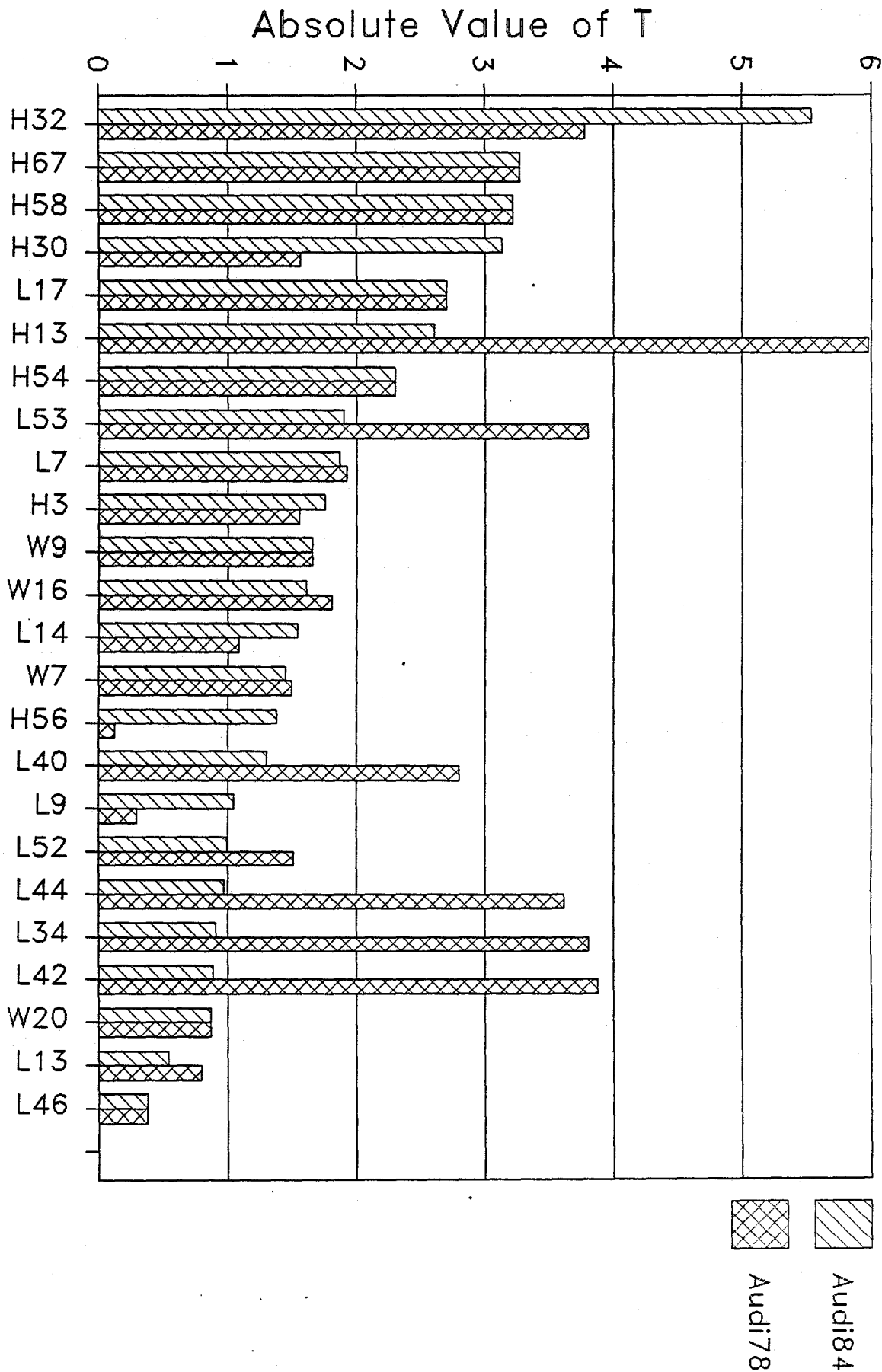

SAE Dimensions as Described in Table 7-1
FIGURE 7-1. T TABLE FOR AUDI

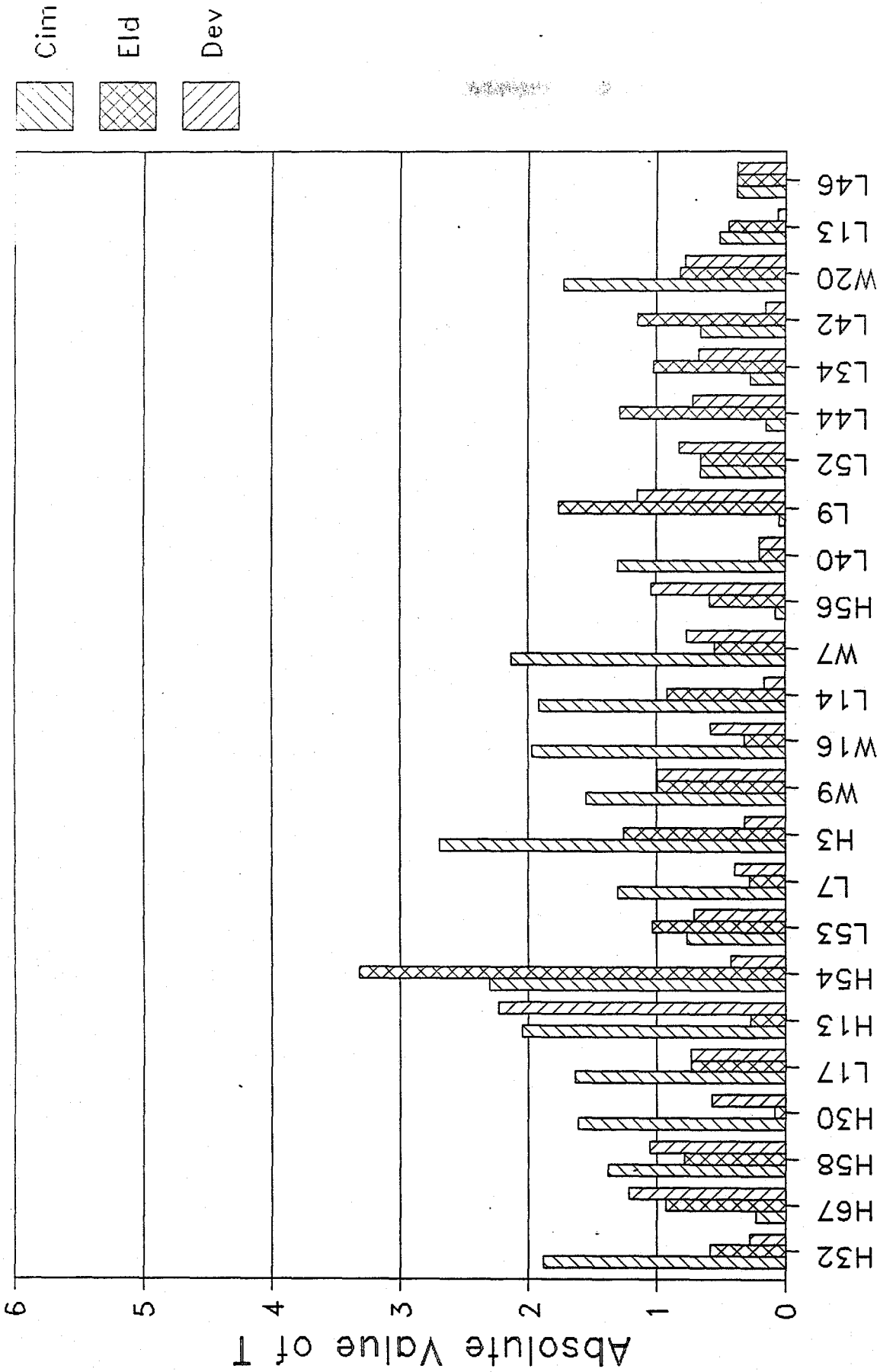

SAE Dimensions as Described in Table 7-1

FIGURE 7-2. TABLE FOR CADILLAC

- The maximum effective leg room to the accelerator (L34) of the 1984 to 1986 Audi is within 1 standard deviation of the GM mean, but that of the 1978 to 1983 Audi is significantly different (3.8 T).
- The steering wheel (nonadjustable in the Audi) is also closer to the centerline of the thigh in the Audi than in a standard GM vehicle (H13).

Table 7-2 compares a limited number of the Audi interior dimensions to other available databases. The first three sections of the table compiled by TSC (VEH 75, 79, and 80) compare the Audi to over 100 of the most popular domestic and imported vehicles in each of those model years. In the VWATTS table, the same Audi dimensions are compared to 4,000 1965 through 1975 domestic and foreign vehicles. Of interest is the similarity between the VWATTS and the VEH 75, 79, and 80 derived means from year to year, and to the previously discussed GM data.

The only dimension in these sets that appears to change with time is the H-point travel (longitudinal seat travel), which has increased from a mean of 129.5 mm in the VWATTS (1965 to 1975) to 154.9 mm in the 1980 database. The Audi's H-point travel is 215.9 mm. It is interesting to note that the smaller cars appear to have a longer seat travel. (GM's post-1980 front-wheel-drive J-, X-, A-, and F-body lines have a seat travel of 190 mm.) This probably reflects a need to make the smaller cars more accommodating.

As most Audi 5000s have eight-way adjustable power seats, the seating arrangement was further investigated by using three individuals who approximated a 5th percentile female (59.5 in height), a 50th percentile male (68.8 in), and a 95th percentile male (73.2 in.). The subjects were instructed to adjust the seat to a comfortable driving position and drive the vehicle to confirm or readjust their selection. The subjects were photographed (Figures 7-3 through 7-5) and their comments solicited. The 5th and 50th percentile subjects described their seating accommodation as very comfortable ("one of the best ever encountered"). The 95th percentile subject found that leg and knee room was limited, even with the seat in its most rearward position. This subject also felt that this could affect the pedal activation.

Although these three subjects found the car to be accommodating, other Audi owners and drivers contacted commented on the fact that the steering-wheel and seat centerlines were displaced, with the steering wheel being to the right of the center of the seat.

Table 7-3 shows pedal dimensions, and the driver's lateral placement with respect to the steering wheel. For 31 1983 through 1987 vehicles, examples of these measurements for individual vehicles can be found in Appendices E and F. In Appendix E, the data are presented from 84 1973 through 1981 domestic vehicles. Appendix F provides data for 75 1982 through 1985 vehicles.

These data are combined and compared using the T value in Figures 7-6 through 7-8. They indicate that significant changes have taken place in pedal dimensions and arrangements from 1975 to 1987. As can be seen in Table 7-4, these differences are more evident in the means for each of the previously mentioned data sets. (The Cadillac comparisons were used for the reasons noted above.) These trends indicate that the right side of the brake pedal has been moved further to the right in relation to the steering wheel; the brake pedal is also slightly narrower, and its length is increasing. In addition, there appears to be a slight increase in accelerator-pedal width and a significant decrease in its length. The distance from the accelerator pedal to the center floor hump is increasing, reflecting downsizing and the switch to front-wheel drive. (In fact, in some vehicles, the center hump is no longer evident.) This can be seen in a comparison of 1979 and 1985 Cadillacs.

TABLE 7-2. COMPARISON OF OTHER INTERIOR DIMENSIONAL DATABASES TO THE AUDI

Database and SAE Designation	Dimension	#of Cases	Mean	SD	Min.	Max.	Audi 1984
VEH75							
L34	Maximum Effective Leg Room Accelerator	117	1066.8	22.9	975.4	1120.1	1061.7
H30	H-Point to Heel Point	106	210.8	17.8	154.9	276.9	289.6
L17	H-Point Travel	117	134.6	12.7	114.3	165.1	215.9
H1B	Steering-Wheel Angle Vertical	103	20.9	3.0	14.4	26.4	21.0
L40	Back Angle	110	26.1	0.9	24.0	33.0	25.0
VEH79							
L34	Maximum Effective Leg Room Accelerator	101	1069.3	25.4	1016.0	1115.1	1061.7
H30	H-Point to Heel Point	107	213.4	25.4	152.4	261.6	289.6
L17	H-Point Travel	106	144.8	20.3	76.2	190.5	215.9
H1B	Steering-Wheel Angle Vertical	107	22.4	7.1	15.0	46.8	21.0
L40	Back Angle	107	25.7	1.5	23.0	33.0	25.0
VEH80							
L34	Maximum Effective Leg Room Accelerator	92	1069.3	25.4	1000.8	1115.1	1061.7
H30	H-Point to Heel Point	91	223.5	27.9	154.9	279.4	289.6
L17	H-Point Travel	92	154.9	30.5	0.0	198.1	215.9
H1B	Steering-Wheel Angle Vertical	89	22.1	7.1	15.0	50.6	21.0
L40	Back Angle	90	25.7	1.1	24.0	33.0	25.0
VWATTS							
L34	Maximum Effective Leg Room Accelerator	4166	1069.3	17.3	591.8	1160.0	1061.7
H30	H-Point to Heel Point	3872	215.9	15.2	96.5	287.0	289.6
L17	H-Point Travel	3227	129.5	12.7	96.5	248.9	215.9
H1B	Steering-Wheel Angle Vertical	817	21.6	2.7	14.3	59.6	21.0
L40	Back Angle	843	26.1	9.4	0.2	97.0	25.0

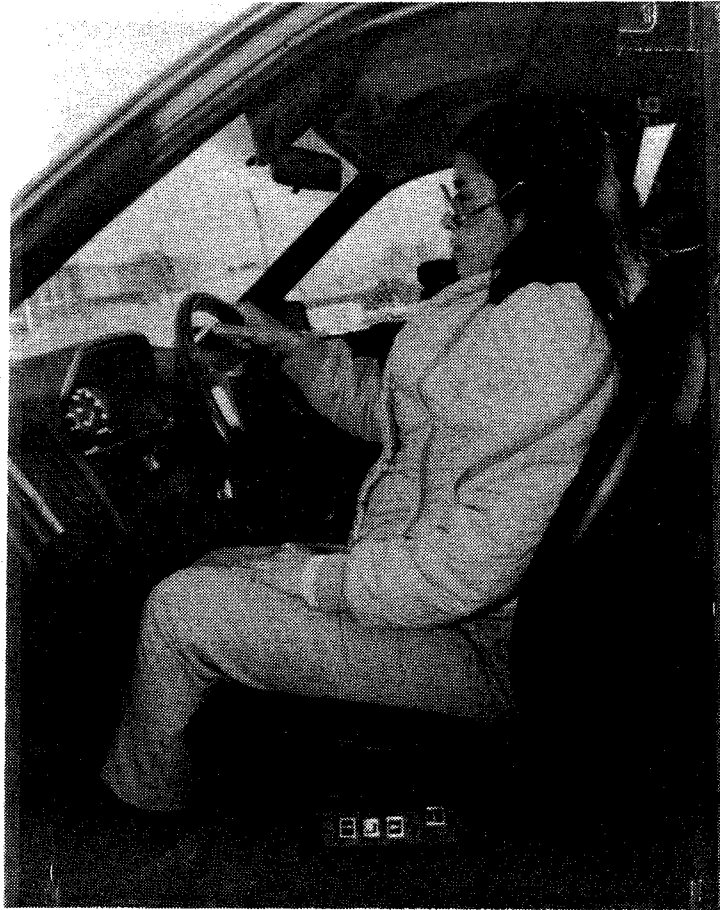

FIGURE 7-3. 5TH PERCENTILE FEMALE (59.5 IN) IN AUDI DRIVER'S SEAT

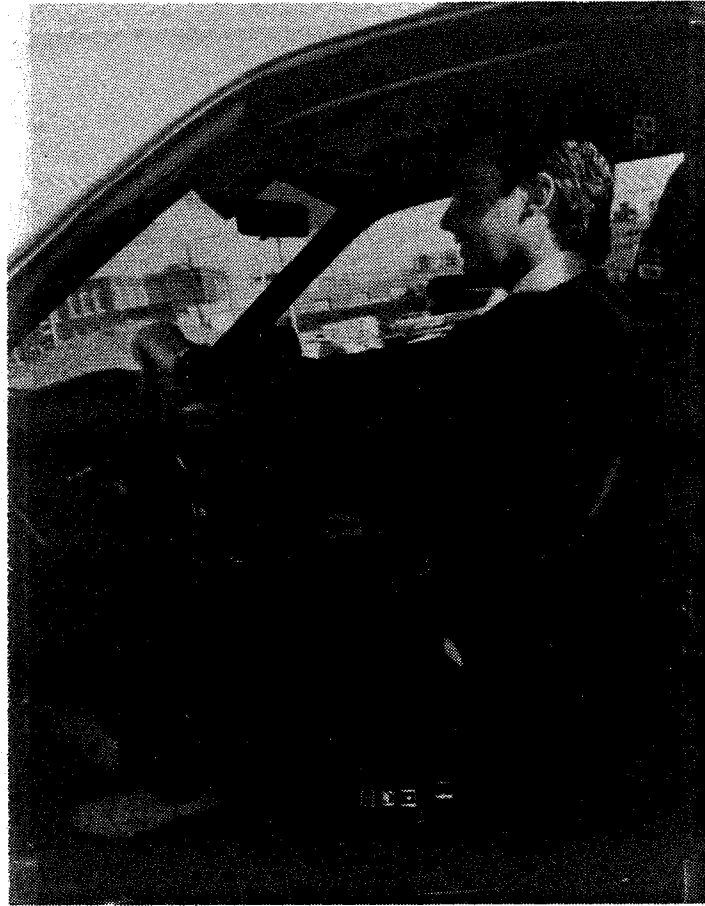

FIGURE 7-4. 50TH PERCENTILE MALE (68.8 IN) IN AUDI DRIVER'S SEAT

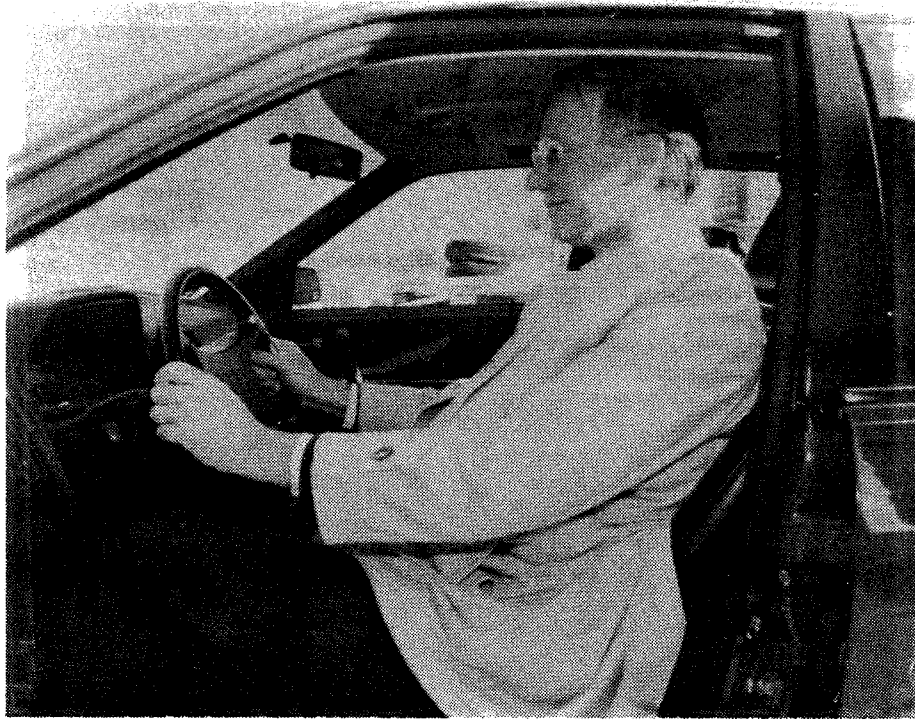

FIGURE 7-5. 95TH PERCENTILE MALE (73.2 IN) IN AUDI DRIVER'S SEAT

TABLE 7-3. PEDAL DIMENSIONS AND DRIVER'S LATERAL PLACEMENT (mm)

MAKE/MODEL		YR	C1T	C1B	E2	F3	X4T	X4B	X12	A13
PONTIAC	GRAND AM	85	47.63	57.15	127.00	63.50	111.13	120.65	31.75	122.24
ISUZU	IMPULSE	83	49.21	49.21	146.05	66.68	107.95	107.95	-6.35	12.70
FORD	MUSTANG	84	31.75	31.75	136.53	50.80	82.55	66.68	-4.76	45.40
CADILLAC	COUPE DEVILLE	87	50.80	60.33	130.18	53.98	136.53	120.65	-14.29	90.49
CHRYSLER	LEBARRON GTS TURBO	87	44.45	53.98	111.13	60.33	139.70	139.70	3.18	66.68
DODGE	LANCER	87	50.80	50.80	107.95	60.33	142.88	142.88	00	79.38
BUICK	ELECTRA SEDAN	86	50.80	57.15	130.18	50.80	130.18	120.65	-28.58	102.33
CHEVROLET	CELEBRITY WAGON	86	57.15	69.85	133.35	57.15	139.70	107.95	00	109.47
SABLE	GS WAGON	87	63.50	69.85	133.35	73.03	120.65	120.65	6.35	92.08
PONTIAC	FIERO	85	50.80	57.15	127.00	44.45	95.25	79.38	3.18	62.71
CHRYSLER	RELIANT WAGON	85	50.80	50.80	107.95	57.15	139.70	139.70	9.53	101.60
AUDI	5000S	85	46.04	46.04	117.48	66.68	101.60	76.20	12.70	31.75
VW	QUANTUM GL5	87	47.63	47.63	101.60	53.98	80.96	77.79	15.88	11.11
HONDA	ACCORD DX	87	50.80	53.98	119.06	69.85	149.23	130.18	15.88	110.11
FORD	LTD	86	30.16	30.16	146.05	60.33	101.60	85.73	-11.11	27.62
AUDI	5000CS TURBO	85	53.98	53.98	98.43	66.68	101.60	76.20	19.05	12.70
AUDI	4000S FUEL INJ	85	47.63	47.63	101.60	53.98	80.96	80.96	31.75	44.45
AUDI	5000S	87	46.04	46.04	117.48	66.68	101.60	76.20	17.46	33.34
HONDA	ACCORD LX	85	44.45	53.98	120.65	53.98	130.18	123.83	22.23	91.31
VW	GOLF	87	41.28	41.28	104.78	65.09	80.96	60.33	19.05	41.28
CHRYSLER	LANCER	85	53.98	53.98	111.13	60.33	136.53	136.53	-3.18	76.20
TOYOTA	CRESSIDA	82	44.45	44.45	111.13	63.50	120.65	120.65	4.76	65.09
NISSAN	300ZX	85	50.80	50.80	158.75	69.85	114.30	85.73	-40	-7.54
VOLVO	GL 4 DOOR	83	34.93	47.63	123.83	76.20	123.83	123.83	-3.18	30.16
PONTIAC	6000 STF	86	57.15	69.85	133.35	60.33	146.05	123.83	9.53	122.24
CHEVROLET	CHEVETTE	85	31.75	31.75	69.85	63.50	60.33	44.45	36.51	6.35
RENAULT	ALLIANCE	83	44.45	44.45	111.13	63.50	104.78	104.78	19.05	44.45
CHEVROLET	CAVALIER RS	87	47.63	57.15	127.00	63.50	111.13	95.25	19.05	95.25
CADILLAC	BROUGHAM	87	53.98	76.20	222.25	60.33	146.05	127.00	28.58	33.34
CHEVROLET	CAPRICE CLASSIC	87	57.15	73.03	155.58	60.33	146.05	127.00	-28.58	33.34
CADILLAC	SEVILLE	87	57.15	66.68	130.18	63.50	142.88	127.00	-28.58	127.76
	MAXIMUM		63.50	76.20	222.25	76.20	149.23	142.88	36.51	127.76
	MINIMUM		30.16	30.16	69.85	44.45	60.33	44.45	-28.58	-7.54
	MEAN		48.03	53.05	124.90	61.30	117.01	105.49	6.34	61.79
	STANDARD DEVIATION		7.75	11.40	25.16	6.78	23.87	26.43	17.00	38.45

LEGEND

- C1T = ACCEL. PEDAL WIDTH AT TOP
- C1B = ACCEL. PEDAL WIDTH AT BOTTOM
- E2 = ACCEL. PEDAL LENGTH
- F3 = BRAKE PEDAL LENGTH
- X4T = BRAKE PEDAL WIDTH AT TOP
- X4B = BRAKE PEDAL WIDTH AT BOTTOM
- X12 = SEAT CEN. TO ST. WHEEL CEN
- A13 = ST. WHEEL CEN. TO RIGHT SIDE OF BRAKE PEDAL

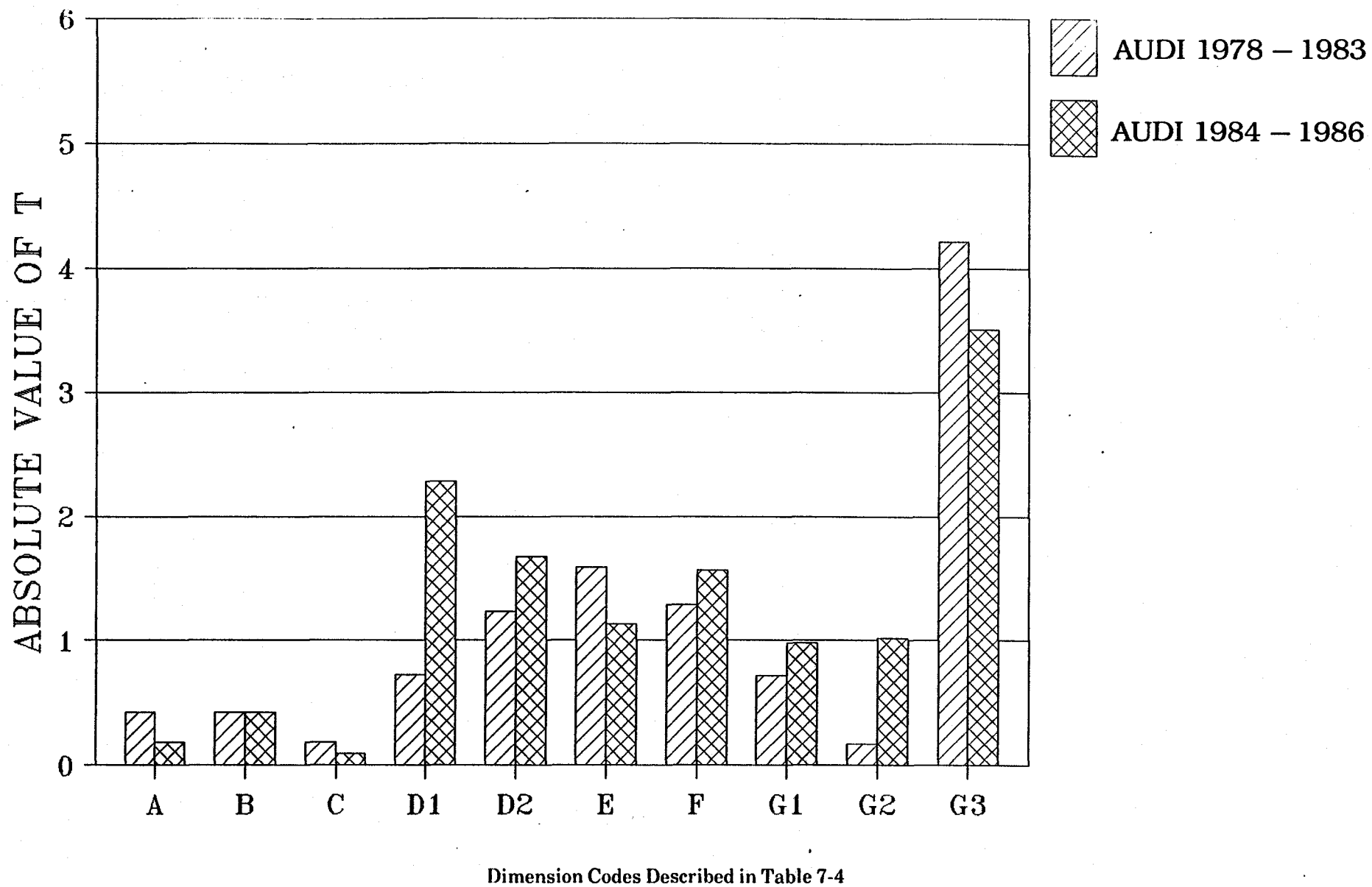
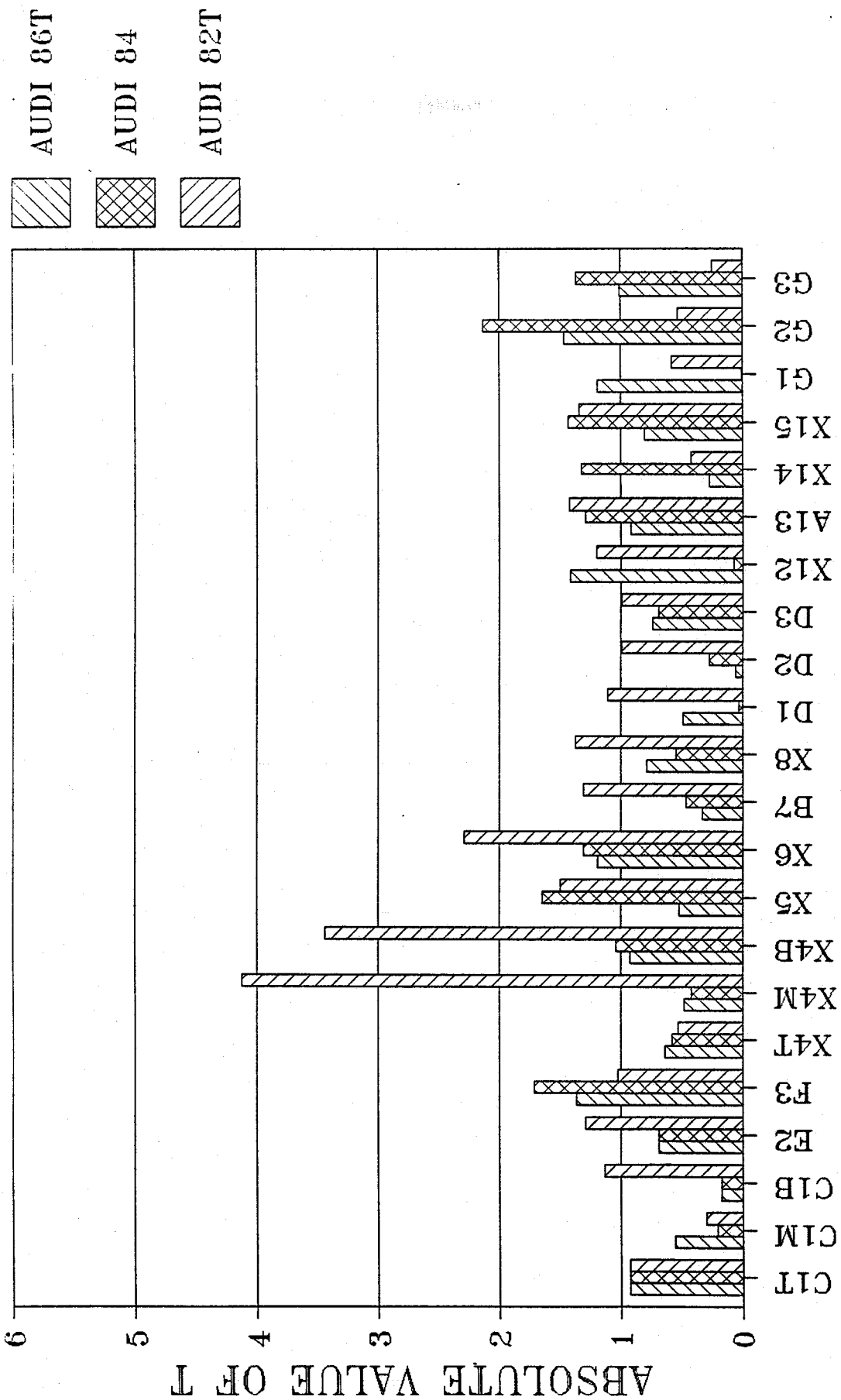

FIGURE 7-6. T VALUES FOR 1973-81 ODI DATA COMPARED TO 1978-86 AUDI 5000



Dimension Codes Described in Tables 7-3 and 7-4

FIGURE 7-7. T VALUES FOR 1982-86 TSC DATA COMPARED TO 1982-86 AUDI 5000

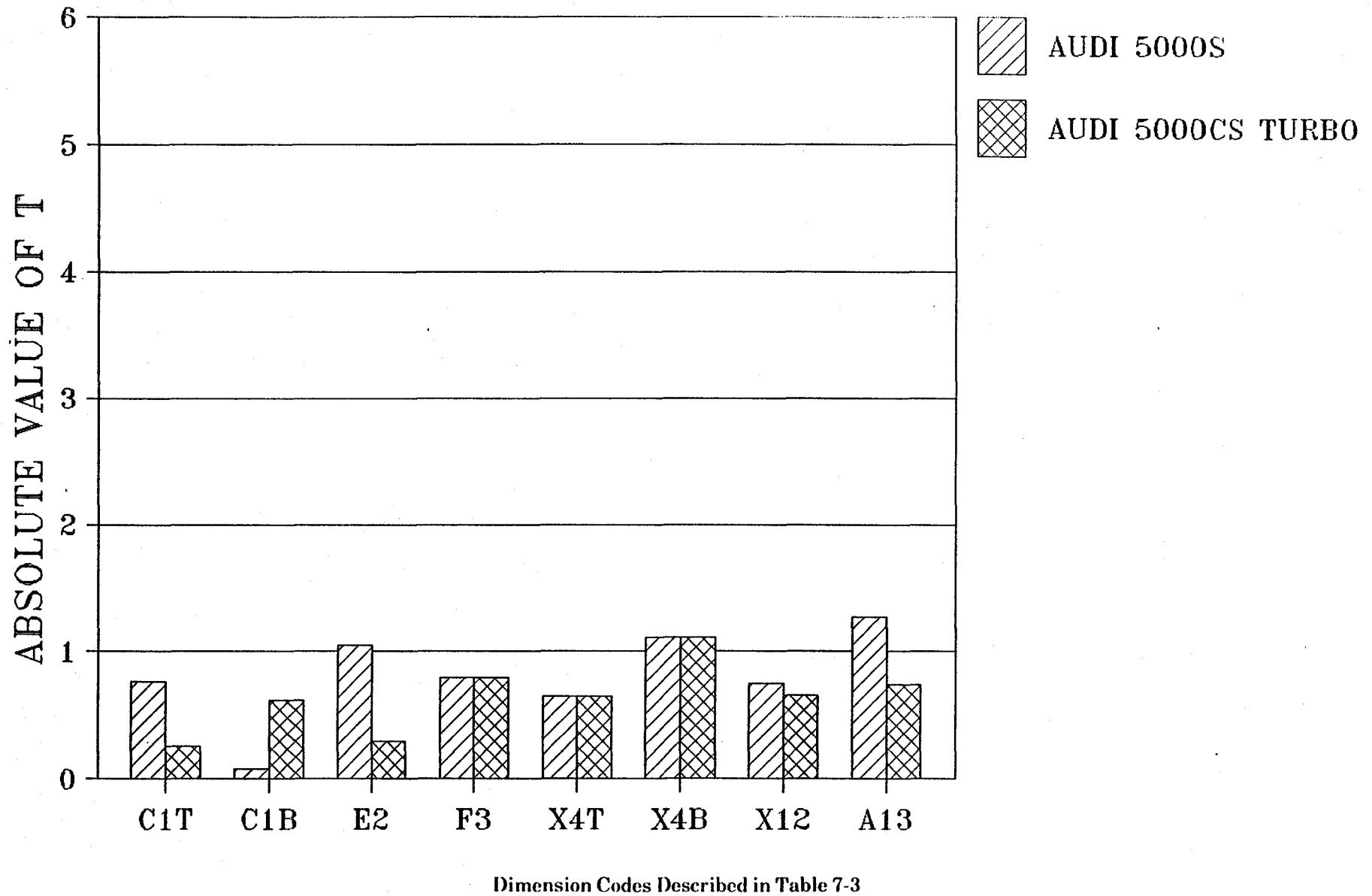

FIGURE 7-8. T VALUES FOR 1982-87 ODI DATA COMPARED TO 1985-86 AUDI 5000

TABLE 7-4. AVERAGE PEDAL DIMENSIONS (mm) COMPARED TO AUDI 5000 AND SELECTED CADILLACS

ATTRIBUTE MODEL YEAR	NHTSA/ODI		TSC 84-85	AUDI		CADILLAC				
	75-81	83-87		5000 78-83	5000 84-86	CIMARRON	COUPE DEVILLE		ELDORADO	
					83	78	85	79	85	
A Steering Wheel to Right Side of Brake Pedal	28.3	61.7	58.6	15.7	34.0	37.3	32.0	63.5	80.0	76.2
X4T Brake-Pedal Width	--	111.2	112.8	110.0	88.9	---	---	129.3	---	194.6
B Horizontal Pedal Separation	71.5	67.8	80.5	60.3	60.2	73.0	63.5	63.0	57.1	---
C Accelerator-Pedal Width	54.7	50.5	49.0	51.6	53.2	50.0	79.0	52.3	78.0	63.5
D1 Accelerator Pedal to Top Edge Hump	17.2	---	53.0	30.2	57.9	---	18.0	---	66.0	124.0
D2 Accelerator Pedal to BTM Edge Hump	13.4	---	41.8	30.2	36.1	---	12.0	---	58.0	70.0
E Accelerator-Pedal Length	154.5	125.0	132.5	82.5	103.1	123.9	233.0	137.0	195.0	190.0
F Brake Pedal-Length	51.6	61.2	58.3	65.0	67.9	47.5	61.0	65.8	67.0	65.0
G1 Vertical Pedal Separation 0 lb	62.3	---	69.3	52.3	48.7	88.1	69.0	86.6	66.0	72.9
G2 Vertical Pedal Separation 20 lb	17.5	---	32.0	29.4	17.5	42.9	41.0	42.9	19.0	50.8
G3 Vertical Pedal Separation 75 lb	-7.6	---	-55.1	-58.6	-47.1	-66.0	21.0	-67.0	-2.0	-72.9
Total Travel G1-G3	69.9	---	124.4	110.9	95.8	154.1	48.0	153.6	68.0	145.8

Another significant change which has occurred is in the brake-pedal "feel" and travel under identical applied forces. The older (1975 to 1981) "full-size" cars had significantly "harder" power brakes with much less total travel. The mean pedal travel for these vehicles (engine running) with 75 lb. of applied force is 69.9 mm, whereas the total travel for 1984 to 1985 vehicles is 124.4 mm. Again, a comparison of old and new Cadillacs dramatically illustrates this change. The 1978 DeVille's brake pedal only traveled 48.0 mm (less than 2 in) with 75 lb. of force, whereas the 1985 model traveled 153.6 mm. By way of comparison, Audi has increased the hardness of its brakes; the 1978 to 1983 Audi was 110.9 mm at 75 lb., and the 1984 to 1986 Audi had 95.8 mm of travel. (Note: This difference may reflect vehicle-to-vehicle measurement differences and not design differences.)

The Audi's pedal dimensions and locations are, with a few notable exceptions, similar to the vehicles found in the 1984 to 1985 data, both domestic and imported, but significantly different from older domestic vehicles. The exceptions are the distance from the right side of the accelerator and brake pedal to the steering-wheel centerline, which was less than that found in the aggregate, and the shorter length of the accelerator pedal.

In the 1985 Audi, for example, the distance between the steering-wheel centerline and the right side of the brake pedal was 1.25 in, while the mean distance from steering-wheel centerline to the right side of the brake pedal in the 1983 to 1987 ODI data set was 2.43 in (SD = 1.5).

The Audi accelerator pedal is further from the center hump than other vehicles (some front-wheel-drive vehicles have indistinguishable humps). Table 7-5 compares some other Audi pedal dimensions to newer domestic and foreign vehicles. These dimensions are not available for older vehicles. Of interest here are the accelerator and brake-pedal heights. The average accelerator-pedal height for all vehicles in the databases previously referenced is 71.0 mm, whereas the Audi was 139.0 mm in 1983 and 110.0 mm in 1986. Comparable numbers for the brake-pedal heights are 147.3 mm for all vehicles and 168.0 mm and 152.0 mm for the Audis, respectively. These results indicate that the Audi accelerator pedal is significantly higher than that of other vehicles, whereas the brake pedal is similar in height.

There are no automotive industry standards for pedal arrangements and forces. However, the dimensions and forces recommended for use in military systems (Vancott et.al.) are given in Table 7.5. Comparisons of these dimensions with those of Audi and the U.S. fleet again indicate that the Audi brake pedal, though somewhat smaller than optimum, is not significantly different from the overall fleet average. The accelerator pedal, however, is significantly shorter and higher than both the optimum and the overall fleet average.

In summary, the Audi driving compartment is different from that encountered in older foreign and domestic vehicles and, to a lesser degree, newer domestic vehicles. On the average, only 6 Audi seating attributes out of 22 were within 1 standard deviation of the mean for all GM vehicles from 1975 to 1983. The Audi seat is higher and harder than the equivalent domestic vehicle, and the floor covering is thicker. In adjusting the Audi seat to accommodate a small driver, the knee angle and seat depth are less than optimum and may contribute to a compromised driving position. The centerline of the Audi seat is displaced to the left of the centerline of the steering wheel by less than 20 mm, although some drivers complained about the misalignment of the steering wheel. Subjects representing 5th percentile females and 50th and 95th percentile males were tested in the vehicle and found the eight-way power seat to be very accommodating. The only complaint was the lack of leg room for the tall male.

TABLE 7-5. FLOOR PEDAL DIMENSIONS

	<u>Recommended</u>	<u>Avg. All</u>	<u>Audi</u>	
			<u>78-83</u>	<u>84-86</u>
<u>BRAKE</u>				
Width	102 mm	112.0	100.0	88.9
Length	76 mm	57.0	65.0	67.9
Height	203 mm	147.3	168.0	152.0
Force in Normal Operation	4 to 30 lb/ft	---	---	---
Normal Travel	50 to 150 mm	97.1	111.0	96.0
<u>ACCELERATOR</u>				
Width	89 mm	51.4	51.6	53.2
Length	250 mm	137.3	82.5	103.1
Height	76 mm	71.0	139.0	110.0
Force	6 to 9 lb/ft	---	---	---
Normal Travel	20°	---	---	---
<u>HORIZONTAL PEDAL SEPARATION</u>				
	76 mm	70.0	80.5	60.3

Recent research, funded by Audi and conducted by Rogers and Wierwille (1988), indicated that differences in pedal configurations can be associated with large differences in pedal-use errors. In this study, only the frequency of relatively minor errors had a statistically significant relation to pedal configuration. (The frequency of serious errors observed during the course of the study was too low to be tested conclusively.)

The pedal dimensions and forces may be of particular interest because the basic clues a driver uses to determine which pedal he or she is depressing are:

- the absolute and relative height of the brake and accelerator pedals
- the force deflection characteristics of the pedals
- the lateral location of the accelerator and brake pedals relative to each other and to landmarks such as the steering-wheel centerline and the center hump.

In the 1978 to 1983 and 1984 to 1986 Audi 5000, a number of these dimensions are outside the range of those found in the U.S. vehicle fleet for the periods when the Audi vehicle was marketed. It can be speculated that the nonconformity of the Audi dimensions to other vehicles in the U.S. fleet contributes to the likelihood of pedal misapplication.

A comparison of the Audi dimensions and forces to the U.S. data lends support to the hypothesis that a driver who is familiar with an older domestic vehicle may find the Audi seating and pedal arrangement to be different, thereby increasing the likelihood of stepping on the throttle pedal rather than the brake in a panic situation.

7.3 DRIVER FACTORS

In this section, the characteristics of drivers involved in SAIs and the driving conditions under which SAIs occur are discussed.

One possible reason that Audi 5000s are overrepresented with regard to SAIs is that Audi drivers may have been drawn from a population of drivers having more of these types of accidents. The likelihood of an individual being involved in an accident may be statistically related to factors such as the driver's age, sex, and height; the familiarity of the driver with the vehicle; and the frequency of exposure of the vehicle to situations wherein such accidents are likely to occur. To better understand the influence of factors such as driver characteristics and situational exposure, TSC compared the Audi incidents to accidents found in the NASS and CARDfile traffic accident databases.

Accident databases were chosen because of the lack of traffic-related incident databases. Incidents and accidents are both unintended phenomena, and although the Audi SAIs did not always result in an accident, the potential similarities in causation make the comparisons that follow valuable in understanding the problem.

Audi driver characteristics such as age, sex, and height are considered for a number of reasons. (See Section 7.3.2 for a detailed discussion of driver height.) It is known that driver age relates to accident rate. Numerous studies have indicated that both the youngest and oldest drivers are over-involved in accidents. In terms of frequency, males are responsible for far more than half of the total accidents. However, in terms of exposure (i.e., accidents per vehicle mile of travel as implied by NPTS data), the rate for men and women is approximately the same. This is because men drive twice as many miles as women. Exposure is, of course, a much more complex factor than miles driven. It involves considerations such as traffic density, weather conditions, time of day, and trip length. All of these factors relate to the economic situation of the buyer or driver and the use to which the vehicle is

subjected. Finally, driver height is of value in relating driver-size characteristics to the interior compartment and pedal measurements that were discussed in the previous section.

7.3.1 Age and Sex

Table 7-6 gives the age and sex distribution of drivers involved in Audi SAIs and compares them to all drivers involved in Audi accidents in the state of Texas in 1984 (from CARDfile) and drivers involved in all accidents in 1984 (from both NASS and CARDfile). (Note that the Texas accidents may include sudden acceleration-caused accidents.) NASS and CARDfile both show that young male and female drivers are overrepresented in accidents. However, males are involved in twice as many accidents as females. Male drivers under 30 are involved in approximately 30 percent of the accidents. Females follow these same trends, but at one-half the rate. The incidence of accidents then decreases in middle age and increases slightly with old age. In total, males account for more than 60 percent of the accidents.

When 704 Audi accidents in the state of Texas were examined, a somewhat different picture appears; male drivers under 30 were found to be involved in about 20 percent of all accidents and females under 30 in about 18 percent of the accidents. The middle ages (30 to 50) show an increase in both male and female accident involvement, accounting for approximately 25 percent each. Males were responsible for 53.0 percent and females for 48.8 percent of the Texas Audi accidents. These trends are more evident in the SAI figures. Male and female drivers under 30 years of age account for only 3.6 and 5.3 percent of the incidents reported to ODI. Middle-aged drivers (30 to 49 years of age) were involved in 15.5 and 27.8 percent of the incidents (males and females, respectively). Older (over 50) drivers, both male and female, are also overrepresented relative to all accidents at 20.8 and 24.3 percent. In total, male drivers reported 39.9 percent of the SAIs and females 57.4 percent, almost the opposite of overall accident patterns.

Assuming female drivers are not inherently less safe drivers (they are not more likely to be involved in traffic accidents in general than males), factors other than driver skill are likely to contribute to female over-involvement in the Audi SAIs. These factors include the age and sex of the Audi 5000 buyer and driver population as compared to the general population, the type of driving done in the Audi (exposure of the driver and vehicle) as a function of age and sex, and the drive cycle of the vehicle (trip length and frequency).

According to Audi, the average Audi buyer is a middle-aged male in an upper economic bracket. This suggests that the age of the driver in Audi accidents and SAIs should be higher than for all drivers' accidents. In order to test this hypothesis, the Audi accidents were compared to those of the Cadillac Coupe DeVille in Texas using 1984 CARDfile data (Table 7-7). This comparison assumes that the buyers of Audis and Cadillacs are from similar economic and age brackets.

Approximately the same sex distribution was found in the Cadillac and Audi accidents in Texas, with males slightly outnumbering females. Both vehicle models are somewhat underrepresented in young driver accidents when compared to NASS.

Audi accidents are highest in the 20 to 40 age bracket (for both males and females), whereas the Cadillac is higher in the over 60 age bracket, perhaps reflecting a slightly older driver of the Cadillac. These results indicate that accident age and sex distribution is influenced by the economic situation of the buyer or driver and that either females from better economic circumstances are more frequently involved in accidents (an unlikely hypothesis) or that, proportionately, women are more likely to drive these types of vehicles. Although these economic factors partly explain the over-involvement of middle-aged and older women in SAIs, it would appear that other factors are also at work.

TABLE 7-6 AGE AND SEX OF INCIDENT - AND ACCIDENT-INVOLVED DRIVERS

Age Years	Audi SA*		Audi All		NASS***		CARDfile	
	%		%		%		%	
	M	F	M	F	M	F	M	F
<20	0.3	0.3	4.7	3.9	9.3	4.8	9.1	4.7
20-24	1.3	1.0			12.3	6.0	12.4	6.0
			16.0	14.4				
25-29	2.0	4.0			8.8	4.8	9.9	5.0
30-34	2.0	4.0			6.2	4.0	7.4	4.1
			17.0	19.6				
35-39	4.6	8.6			5.6	3.4	5.6	3.3
40-44	3.6	8.6			3.7	2.4	4.0	2.3
			8.2	6.3				
45-49	5.3	6.6			3.0	1.6	3.0	1.6
50-54	4.0	9.2			2.4	1.1	2.7	1.4
			5.0	3.3				
55-59	5.6	5.6			2.5	1.5	2.6	1.3
60-64	6.6	3.6			2.5	1.6	2.7	1.1
65-69	2.6	3.3	2.1	1.3	1.8	0.6	1.5	0.8
>69	2.0	2.6			3.0	1.5	2.4	1.4
Total	39.9	57.4	53.0	48.8	61.1	33.3	63.3	33.0

* SA - Sudden acceleration

** Assumes unknowns are distributed the same as knowns

*** Excludes those where sex is unknown

TABLE 7-7. COMPARISON OF AUDI AND CADILLAC INCIDENTS

Age Years	Audi SA*		Audi All		Cadillac		NASS**	
	M	F	M	F	M	F	M	F
<20	0.3	0.3	4.7	3.9	3.4	1.9	9.3	4.8
20-29	3.3	5.0	16.0	14.4	9.5	5.7	21.1	10.8
30-39	6.6	12.6	17.0	19.6	9.3	9.3	11.8	7.4
40-49	8.9	15.2	8.2	6.3	9.0	9.7	6.7	4.0
50-59	9.6	14.8	5.0	3.3	9.2	8.6	4.9	2.6
>59	11.2	9.5	2.1	1.3	13.4	10.7	7.3	3.7
Total	39.9	57.4	53.0	48.8	53.8	45.9	61.1	33.3

* SA - Sudden acceleration
 ** Excludes those where sex is unknown

One other factor to consider is exposure, based on vehicle miles traveled and drive cycle. Vehicle miles traveled, in turn, are also related to driver age, sex, and income. Previous studies have shown a slight but consistent overrepresentation of middle-aged females based upon accidents per miles traveled (Figure 7-9). Males and females are comparable on this basis, which is explained by the difference by sex of vehicle miles traveled.

The 1983-84 NPTS indicated that the average annual miles driven by males was 13,962 and by females 6,382. These mileage figures are also associated with income. The NPTS shows that the average annual mileage for households with more than \$40,000 income (average Audi/Cadillac owner) was 11,706 miles, as opposed to the overall average of 10,288 miles (no sex distribution was available). The NPTS also indicates that 87 percent of households with an income of \$40,000 or more, which would include the average Audi/Cadillac owner, own two or more vehicles (average = 2.6 vehicles). The drivers in these households are therefore probably exposed to two or more different vehicles.

The type of driving could also be a factor in the apparent over-involvement of females in the Audi SAIs.

Approximately 70 percent of the vehicle trips and 65 percent of the vehicle miles of travel are related to family business and social and recreational affairs. Tables 7-8 and 7-9 from the NPTS show that females make slightly less work-related trips and more family-related trips. In fact, more than 80 percent of female driving is not work-related, while about 70 percent of the males' trips are not related to work. This non-work-related 80 percent includes family and personal business, including shopping and doctor visits. For women, these types of trips increase from 26.2 percent at ages 16 to 19 to more than 45 percent in middle and older ages. (Males also increase this type of travel, from about 20 percent to more than 30 percent.) This type of driving exposes an individual to frequent starts and stops in which the sudden accelerations are more likely to occur.

In summary, middle-aged female drivers and, to a lesser degree, middle-aged male drivers appear to be overrepresented in Audi SAIs. Part of this overrepresentation can be explained by the economic circumstances of those who buy and drive the car. Income is related to age and can also influence the miles driven per year and the number of vehicles in the family, thus increasing the exposure and decreasing the familiarity with a specific vehicle. As income increases, a larger part of the annual mileage is for family and personal business. Middle-aged women and, to a lesser degree, middle-aged men are overrepresented in these travel categories. Frequent short trips such as shopping, social visits, and doctor visits would increase the exposure of the driver to the start-and-stop driving during which SAIs are most frequently reported.

7.3.2 Height

TSC also examined the heights of the drivers in the NHTSA sudden acceleration reports to determine if incident-involved drivers had any physical characteristics that, in conjunction with the vehicle driver compartment design, could contribute to sudden accelerations. Table 7-10 gives the means, standard deviations, and percentiles (assuming a normal distribution) of the male and female incident-involved drivers, and compares them to the national population. Although the means are approximately the same, the Audi-involved drivers are more broadly distributed, i.e., these populations have a greater proportion of shorter and taller drivers than the general population. An "F" test indicates that the Audi distributions are significantly different from the national population. Figures 7-10 and 7-11 show a normal probability plot of these distributions. Although these plots and the "skewness" show some lack of normality in the distributions, this is not enough to affect the results given in the table. As far as the short and tall drivers are concerned, as noted above, the Audi seat may have some difficulty in accommodating a short person, and the compartment may not offer

10,814 California Drivers (6) 7581 Michigan Drivers (7)

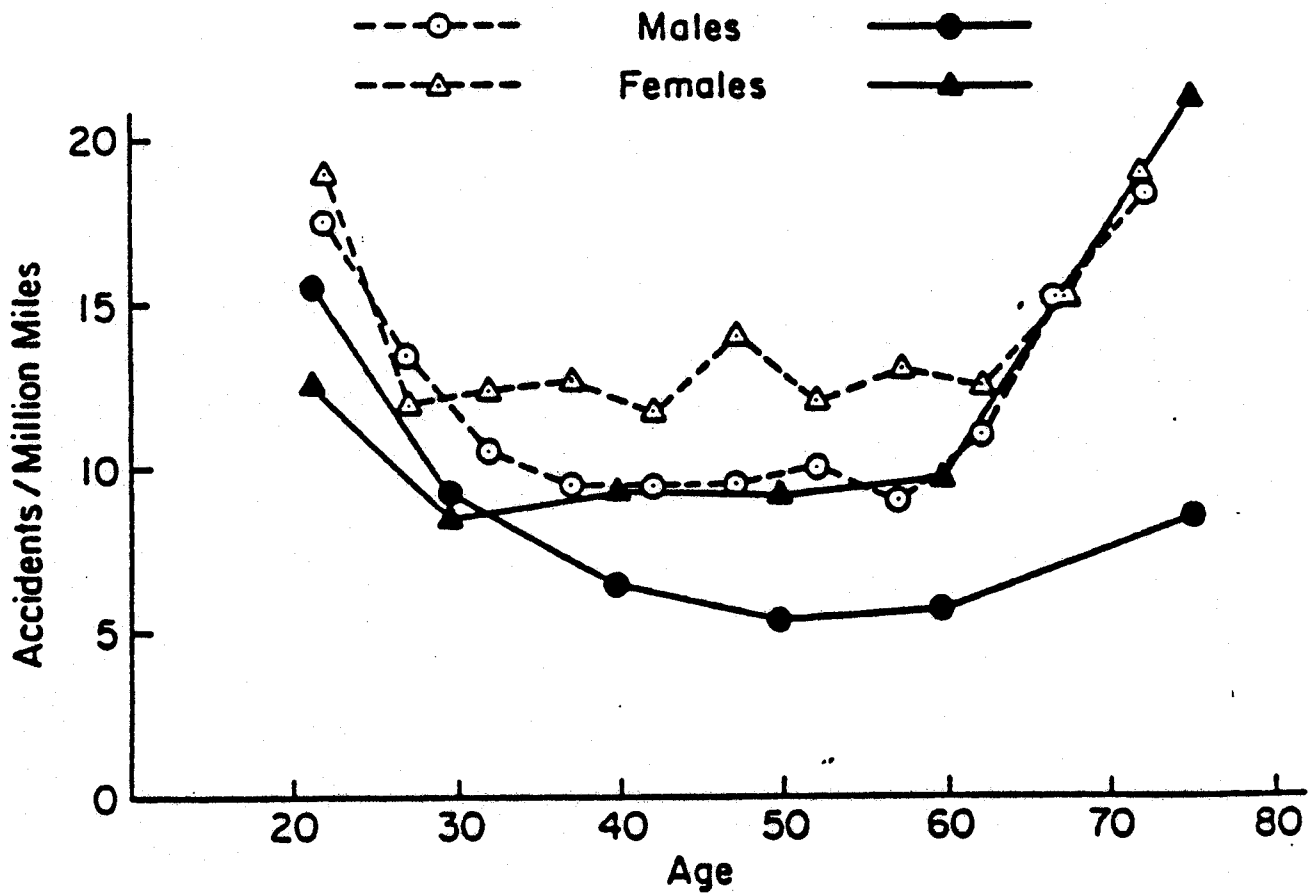

FIGURE 7-9. ACCIDENT RATE AS A FUNCTION OF AGE AND SEX

TABLE 7-8. DISTRIBUTION OF PERSON TRIPS BY PURPOSE, AGE, AND SEX (1983 MALES)

	Age								All
	5-15	16-19	20-29	30-39	40-49	50-59	60-64	65 and Over	
Earning a Living									
To or From Work	1.5	16.2	31.6	33.1	33.9	31.6	26.2	6.7	24.5
Work Related Business	.4	1.6	2.5	4.7	4.4	5.6	3.2	2.1	3.1
Subtotal	1.9	17.8	34.1	37.8	38.3	37.2	29.4	8.8	27.6
Family and Personal Business									
Shopping	9.4	9.4	14.6	16.2	16.4	18.3	19.9	31.2	15.7
Doctor/Dentist	.9	.5	.6	.7	.5	.7	1.7	2.6	.9
Other Family Business	9.0	10.1	14.3	16.7	18.4	16.5	19.2	19.1	15.0
Subtotal	19.3	20.0	29.5	33.6	35.3	35.5	40.8	52.9	31.6
Civic, Educational, and Religious	39.1	24.4	5.6	3.6	3.0	4.4	4.0	5.8	11.1
Social and Recreational									
Vacation	.5	.1	.2	.3	.3	.3	.3	.0	.3
Visiting Friends	11.9	15.8	13.2	9.4	6.1	7.3	10.1	10.3	10.6
Pleasure Driving	.3	.7	.5	.4	.4	.8	.5	1.3	.6
Other Social and Recreational	20.5	19.6	15.5	13.9	15.4	12.5	14.0	18.2	16.0
Subtotal	33.2	36.2	29.4	24.0	22.2	20.9	24.9	29.8	27.5
Other	6.5	1.6	1.4	1.0	1.2	2.0	.9	2.7	2.2
TOTAL	100.0	100.0	100.0	100.0	100.0	100.0	100.0	100.0	100.0

TABLE 7-9. DISTRIBUTION OF PERSON TRIPS BY PURPOSE, AGE, AND SEX (1983 FEMALES)

	Age								All
	5-15	16-19	20-29	30-39	40-49	50-59	60-64	65 and Over	
Earning a Living									
To or From Work	1.2	10.0	21.2	20.8	22.6	22.2	16.4	6.0	16.5
Work Related Business	.5	.6	2.0	2.1	2.1	2.7	.8	.9	1.7
Subtotal	1.7	10.6	23.2	22.9	24.7	24.9	17.2	6.9	18.2
Family and Personal Business									
Shopping	11.2	15.4	18.8	20.4	23.2	25.4	28.8	30.1	20.3
Doctor/Dentist	1.3	.6	1.0	1.6	2.0	1.6	1.6	4.5	1.6
Other Family Business	10.6	10.2	16.8	23.7	20.0	15.1	17.5	17.1	17.2
Subtotal	23.1	26.2	36.6	45.7	45.2	42.1	47.9	51.7	39.1
Civic, Educational, and Religious	36.6	25.1	8.1	6.1	5.5	7.6	6.0	9.2	12.5
Social and Recreational									
Vacation	.3	.2	.3	.4	.3	.4	.4	.3	.3
Visiting Friends	12.5	15.7	14.4	8.7	9.0	9.6	10.8	10.6	11.4
Pleasure Driving	.7	.5	.2	.4	.6	.6	.2	1.3	.5
Other Social and Recreational	18.1	19.9	15.9	14.0	12.9	13.4	15.5	17.3	15.6
Subtotal	31.6	36.3	30.8	23.5	22.8	24.0	26.9	29.5	27.8
Other	7.0	1.8	1.3	1.8	1.8	1.4	2.0	2.7	2.4
TOTAL	100.0	100.0	100.0	100.0	100.0	100.0	100.0	100.0	100.0

TABLE 7-10. DISTRIBUTION OF HEIGHTS FOR MALE AND FEMALE DRIVERS INVOLVED IN SUDDEN ACCELERATION INCIDENTS AS COMPARED TO THE NATIONAL POPULATION

Percentile	Male (in)		Female (in)	
	U.S.	Audi	U.S.	Audi
1	62.6	60.2	57.8	56.5
2.5	63.6	61.5	58.7	57.8
5	64.4	62.6	59.5	58.8
25	67.0	66.1	61.9	62.1
50	68.8	68.5	63.6	64.4
75	70.6	70.9	65.3	66.7
95	73.2	74.4	67.7	70.0
97.5	74.0	75.5	68.5	71.0
99	75.0	76.8	69.4	72.0
n =	>10,000	99	10,000	158
Q	2.67	3.57	2.50	3.41
MAX		76		76
MIN		57		52

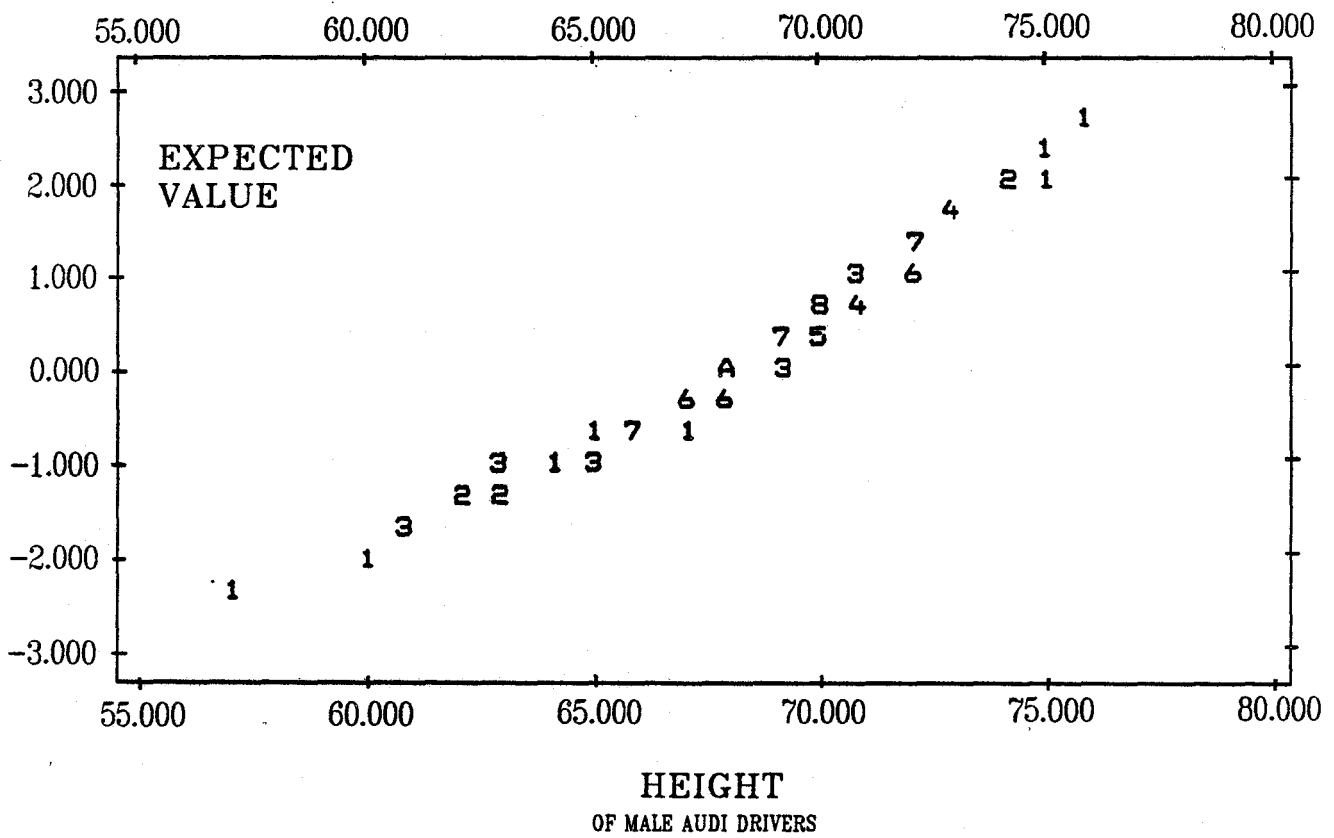

In Figures 7-10 and 7-11, the observed values are plotted along the horizontal axis. The data values are ordered before plotting. The vertical axis corresponds to the expected normal value based on the rank (quartile) of the observation. The plotted points represent the set of points $(x(i), q(i))$ where the $x(i)$ are actual observations after ordering (i.e., $x(1)$ is the point with the least magnitude and $x(n)$ is the largest value) and $q(i)$ is the standard normal with probability level $(i-1/2)/n$. When the points lie very nearly along a straight line, the normality assumption remains tenable.

FIGURE 7-10. NORMAL PROBABILITY PLOT OF MALE AUDI DRIVERS

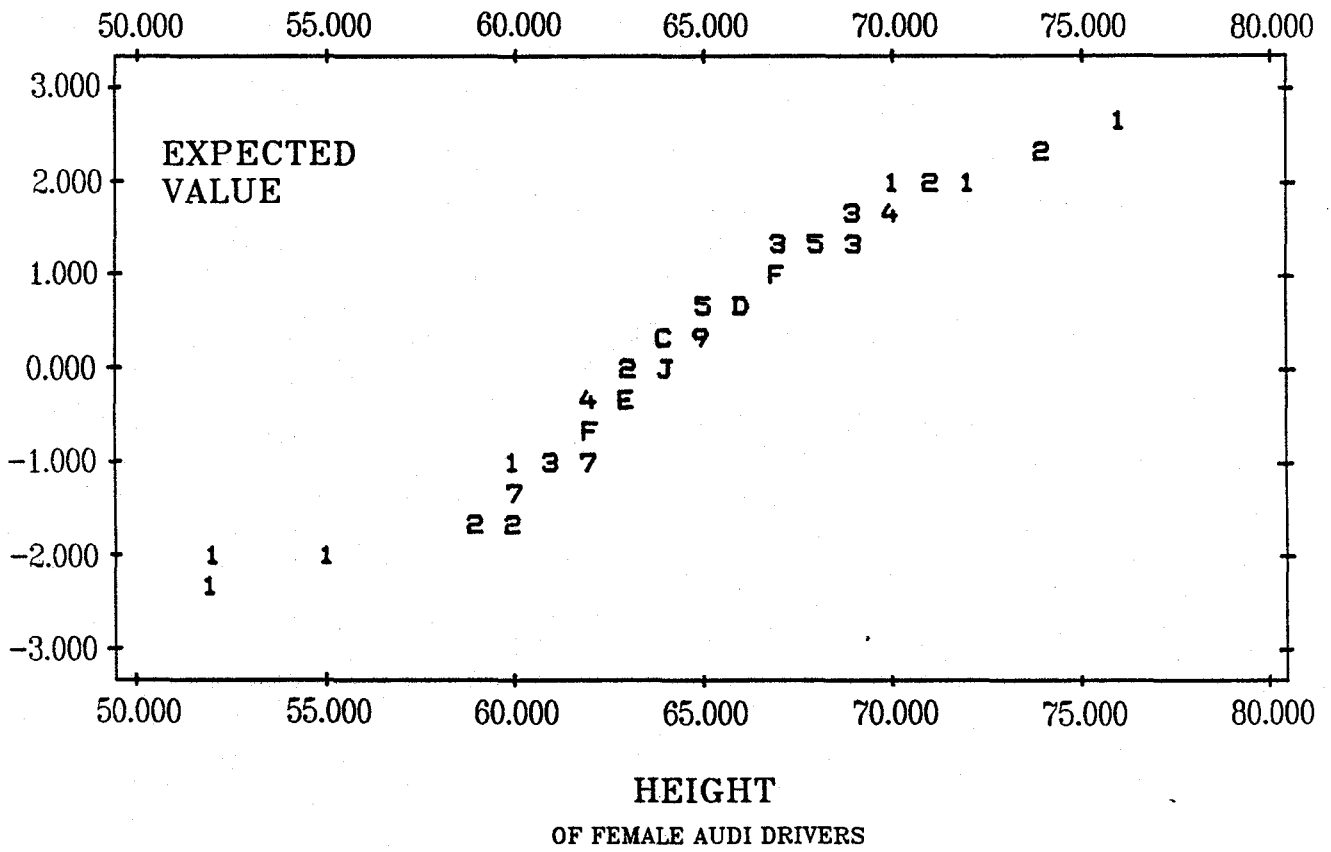

FIGURE 7-11. NORMAL PROBABILITY PLOT OF FEMALE AUDI DRIVERS

enough leg room for a tall person. This data cannot prove height is a causative factor, however, because it is possible that Audi buyers and drivers are taller or shorter than the normal population.

7.3.3 Experience

This section examines experience from two points of view which may be considered a manifestation of the same phenomenon:

- The driver's experience with the vehicle.
- The mileage the vehicle was driven at the time of the accident or incident. (This factor is an indicator of driver inexperience, but may also be indicative of a vehicle component failure that is mileage-or time-related.)

A study performed by NHTSA in 1983 reviewed the accident literature with respect to driver familiarity with the involved vehicle and overall driver experience. Figure 7-12 is taken from that study and indicates that driver experience with the accident vehicle is more closely related to accident rate than overall driving experience. (In fact, 17 to 24 percent of all drivers involved in accidents have less than 1000 miles of experience with the involved vehicle.)

This problem may be more pronounced for Audi SAIs. According to Audi, the majority of the interviewed drivers involved in SAIs did not own the vehicle or did not drive it regularly. The experience of drivers involved in Audi incidents as reported to NHTSA is also plotted in Figure 7-12. These data show that 44 percent of the Audi SAI-involved drivers had less than 6 months of experience with the vehicle. This is substantially greater than the percentage of all accidents experienced by drivers (34 percent in the first 6 months), and may indicate that (1) unfamiliarity with the vehicle is a greater causal factor in sudden acceleration, or (2) the vehicle is new and there is a component problem that manifests itself early in the car's life so that the incident occurs when the owners have had the car for only a short time.

Another way of examining this effect is to consider the odometer mileage at the time of the accident or incident. Figure 7-13 shows the odometer mileage for Audi incidents as reported to both Audi and NHTSA. The Audi figures show that about 70 percent of the SAIs occurred with less than 10,000 miles on the odometer, while the NHTSA data show that 45 percent of the SAIs occurred with less than 10,000 miles driven. Figure 7-14 illustrates the 1984 weighted national accident experience for all vehicles and for Cadillacs, drawn from NASS odometer readings. The overall accident experience is evenly distributed between 3.5 and 4 percent per 5,000 miles of odometer reading.

There remains the hypothesis that the overrepresentation of low mileage incidents is a function of "juvenile" component failure. However, the data do not support this theory. Component failures are contributing factors in only 1 percent of the NASS accidents, and of the 704 Audi accidents in Texas, none were attributed to component failures.

In summary, the data suggest that experience of the driver with a vehicle is a factor in the causation of accidents. This experience factor is strongly represented in the data from the Audi incidents. The Audi incident experience is heavily biased to the low mileages while the general accident experience is more evenly distributed as a function of vehicle mileage.

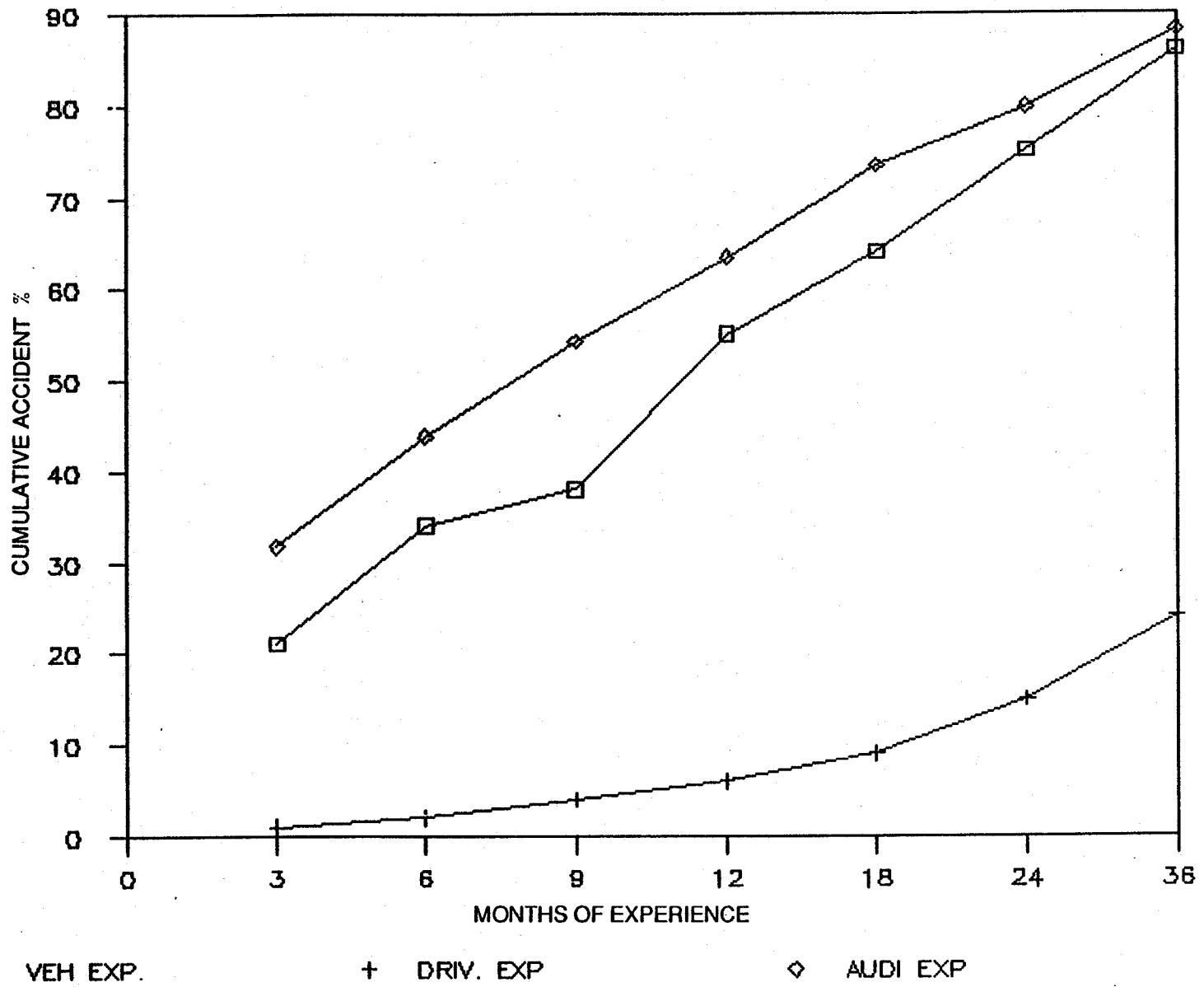

FIGURE 7-12. CUMULATIVE ACCIDENT PERCENTAGE AS IT RELATES TO DRIVER EXPERTISE

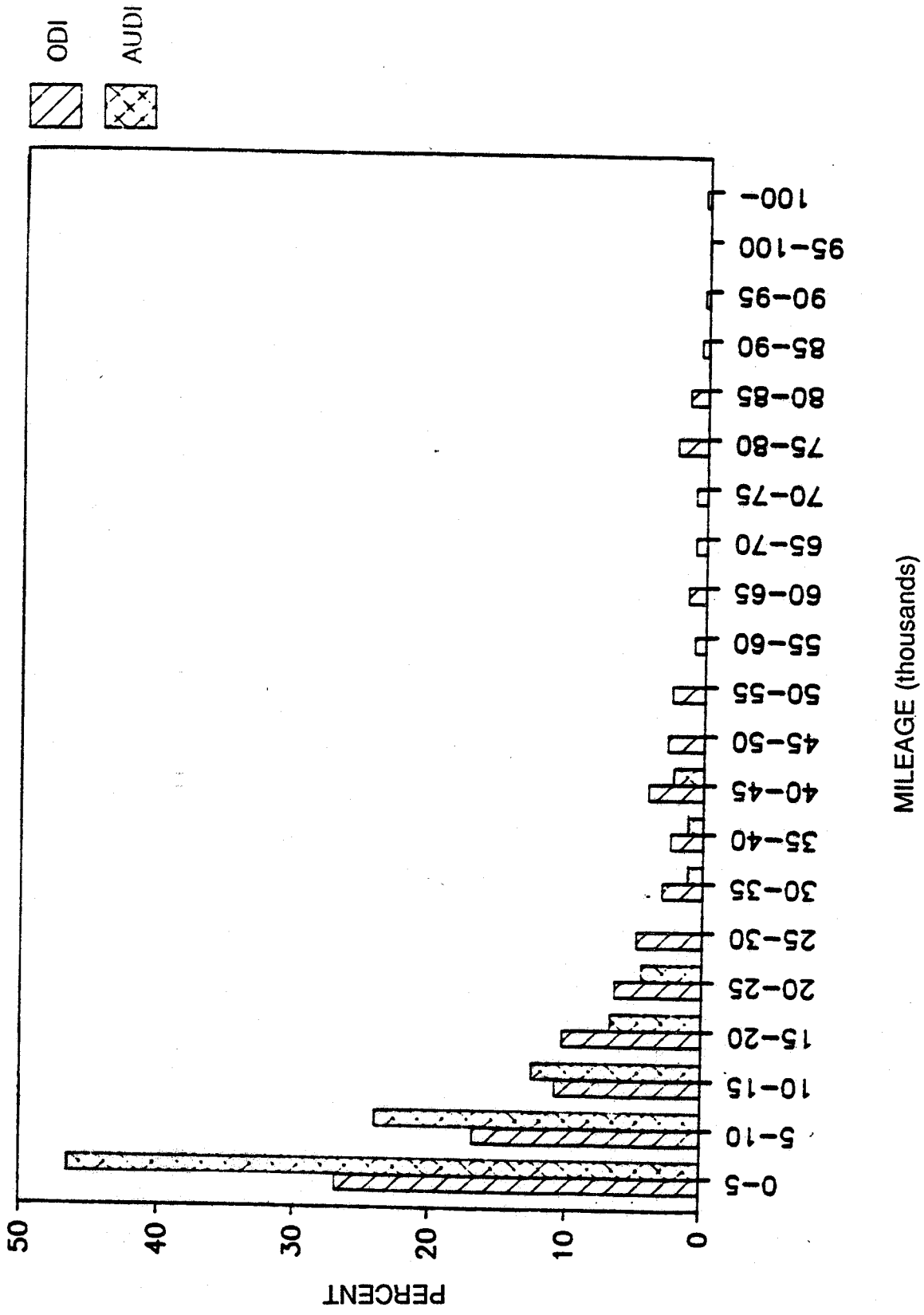

FIGURE 7-13. AUDI INCIDENTS AS A FUNCTION OF MILEAGE

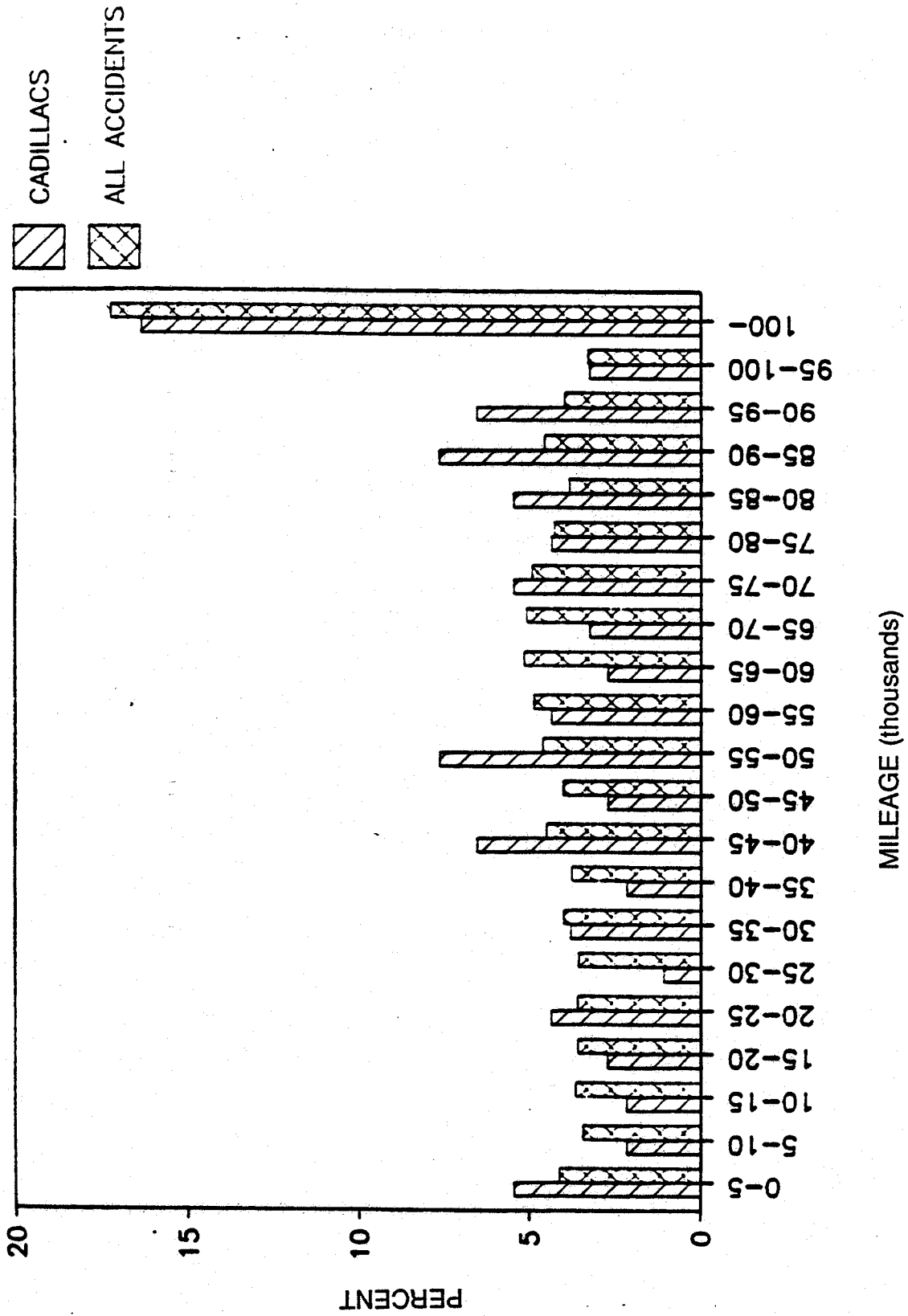

FIGURE 7-14. ACCIDENTS AS A FUNCTION OF MILEAGE

8. RECOMMENDATIONS AND CONCLUSIONS

8.1 POWER TRAIN

The mechanical systems in the Audi that could produce the increase in engine power required to initiate an SAI either directly or by startling the driver are limited. They include the throttle system (the accelerator linkage, transmission "feedback" linkage to the accelerator linkage, and the cruise control) and the idle-stabilizer system (electronic control unit and valve).

8.1.1 Throttle Control System

A failure in this system can directly increase engine power.

Cruise Control System – Multiple failures in this system would be required to produce SAIs under the conditions reported by the involved drivers. Unanticipated acceleration has been observed by TSC and reported to NHTSA and VWOA. However, these acceleration incidents do not resemble the typical SAI in that they have only been observed at highway speeds with the transmission in drive.

Sticking or Binding of Throttle Linkage – After the accelerator pedal is depressed the linkage could "stick," causing the pedal to hold its position. This could be caused by binding in the system or some mechanical interference with the linkage or pedal. Evidence of such sticking or binding should be observed in post-accident investigations. Subsequent to VWOA's recall to modify the accelerator pedal to prevent interference with the floormat, there have been no observed incidents of throttle system sticking.

Transmission Activation of Throttle – In the Audi 5000 from 1978 through 1983, the transmission could activate the linkage and throttle plate in a shift from drive into neutral, reverse, or park. In these models the throttle plate could also be inadvertently opened if the kickdown valve was driven into the transmission by at least 117 psi of pressure. A pressure leak from the transmission main channel is the only source of this high pressure. An SAI due to transmission activation of the throttle would require the failure of one or more valves, would be irreversible, and would be easily detected in post-accident investigations. Such an occurrence has not been observed.

8.1.2 Idle-Stabilizer System

A failure in this system in the Audi 5000 can induce engine surging and unanticipated acceleration. Tests by both VWOA and TSC have indicated that the idle-stabilizer system alone can accelerate the Audi 5000 at 0.3 g reaching speeds of 20 to 25 mph in approximately 10 seconds, eventually reaching speeds of 40 to 50 mph in drive.

Idle-Stabilizer Valve – Two valve configurations have been used by Audi since 1984: a linear valve and a rotationally activated valve. TSC examined three failure modes (mechanical sticking, a "dead spot" on the current collector, and a broken return spring). Only spring failure would cause the valve to stay in the fully open position. Audi has recognized stabilizer valve problems and is examining the valve as part of their recall campaign.

Idle-Stabilizer Electronic Control Unit – Intermittent malfunctions of this unit have been observed and recorded by TSC and others. When this unit malfunctions, excess current flows to the idle-stabilizer valve causing it to open fully, resulting in an immediate increase in engine power. Control unit failures are sometimes temperature-dependent and, because of their intermittent nature, may not be detected during normal Audi-specified testing or in post-accident investigations. The electronic control unit has been repeatedly modified by VWOA. Audi has recalled the earliest three of the five known versions of this unit. This recall has apparently eliminated the problem.

8.2 BRAKING SYSTEM

Potential failure modes in the Audi 5000's braking system which might cause the driver to lose control after the initiation of an SAI were investigated. The typical description of an SAI by the vehicle driver includes a report of often total brake failure.

8.2.1 Complete Brake Failure

This can be caused only by a loss of hydraulic fluid from the master cylinders or brake lines and wheel cylinders or internal leaks in the master cylinder. (All vehicles of the types reporting SAIs have dual hydraulic systems that minimize the chances of losing both front and rear brakes simultaneously.) Such complete failure is irreversible and would be easily detected after an incident. This has not been the case.

8.2.2 Temporary Failure of the Hydraulic Power-Brake Assist

The hydraulic power boost is independent of other engine functions. If the engine is shut down, the reservoir holds sufficient fluid for 15 to 20 brake operations. The reservoir can be depleted by extended engine shutdown. In theory, with the engine at idle, the reservoir could also be depleted by very rapid pumping of the brakes. No such rapid pumping has been reported in descriptions of the events preceding an SAI. Without the power-brake assist, the brakes are still capable of stopping the car, but require four to five times the force from the driver. Even with failure of the power-boost system, the majority of drivers would still be capable of stopping the car after the initiation of an SAI.

Two points must be emphasized. First, if the Audi engine speed is above 1000 RPM as is usually reported in an SAI, rapid pumping of the brake pedal cannot deplete the reservoir. Second, the Audi brakes, when operating properly at the low road speeds typical of the SAI, will hold or stop the car even under wide-open throttle.

8.3 DRIVER FACTORS

Other factors were identified and analyzed which might be related to a disproportionate number of SAIs for the Audi 5000. They were:

- driver-related design factors which increase the likelihood of pedal misapplication
- driver demographic factors which are related to driver subgroup, accident experience, and exposure of the vehicle to situations where SAIs can occur; and physical characteristics of the populations of individuals who drive the vehicles

VWOA's initial claim was that the SAIs were a result of driver error. The Audi 5000 driving environment and the characteristics of the Audi 5000 driver population were analyzed to determine if such factors could cause or contribute to pedal misapplication resulting in the disproportionate number of SAIs reported for the vehicle.

8.3.1 Driving Environment

Prior research by TSC and NHTSA has revealed that driver unfamiliarity with a vehicle can markedly increase the likelihood of an accident. As part of TSC's efforts, a statistical study was performed comparing the Audi 5000's interior seating and pedal arrangements with hundreds of other vehicle models in the U.S. fleet for critical driver-related dimensions. The study revealed statistically significant differences for dimensions such as seat height; lateral steering-wheel position; leg room; brake-pedal force, size, height, and travel; and accelerator-pedal size and height. In particular, the characteristics of the Audi 5000 were more different than older, larger American models and less different than newer front-wheel-drive cars.

8.3.2 Driver Population

The major sources of statistical variation in automobile accident rates are the demographic characteristics of the driver population. Middle-aged and older drivers are overrepresented in Audi 5000 SAIs when compared to drivers in all accidents nationwide. However, such individuals are similarly overrepresented as owners and drivers of Audi 5000s.

8.3.3 Type of Driving

Female drivers are overrepresented in Audi 5000 SAIs when compared to drivers in all accidents nationwide. NPTS shows that females take more trips which require frequent starts and stops, increasing the opportunity for SAIs.

8.3.4 Experience of the Audi 5000 Driver

Approximately 34 percent of all drivers involved in accidents nationwide have less than 6 months of experience with the vehicle involved. In the case of the Audi 5000 SAIs, 44 percent of the drivers had less than 6 months' experience. According to ODI data, more than 45 percent of the SAIs occurred with less than 10,000 miles on the vehicle. NASS accident statistics show that the overall accident rate is relatively evenly distributed between 3.5 and 4 percent per 5,000 miles of driving. The high initial SAI rate for the Audi 5000 could, of course, be indicative of mechanical failures early in the Audi's life. Such early failures, however, have not been detected.

8.4 SUMMARY

In conclusion, the TSC study found that:

- The Audi 5000 has failure modes that could induce intermittent engine surging and unexpected increases in engine power.
- In particular, failures in the idle-stabilizer system have been observed which produced surges under the conditions described in the SAI reports.
- Complete brake failure, as has been reported in SAIs in the Audi 5000, is a very unlikely event, would be detectable after an SAI, and has not been detected in post-SAI investigations.
- The ergonomic characteristics, seating, pedal arrangements, and pedal forces of the Audi 5000 are significantly different from the standard domestic vehicles (especially older vehicles).

- These arrangements and force differences increase the likelihood of driver confusion of the brake and accelerator pedal (particularly for new drivers and particularly after an unexpected, mechanically caused increase in engine power). Studies revealing the correlation between driver unfamiliarity and a high initial vehicle accident rate are consistent with this supposition.

Since many of the features or components of the Audi 5000's systems mentioned above have been introduced, substantially modified, or eliminated in the course of the model years under investigation, no one failure mode can possibly explain all of the reported incidents. One must conclude therefore, that the history of sudden acceleration problems of the Audi 5000 can only be understood in the context of multiple vehicle malfunctions in combination with the ergonomic characteristics and driver factors discussed above.

As with investigations of this problem in other vehicles, we cannot identify any single malfunction in the Audi 5000 which could simultaneously produce sudden acceleration and brake failure and which would leave no readily observable evidence of its occurrence. Rather, we find that malfunction, in the idle-stabilizer system, and to a lesser extent the throttle linkage and the cruise control, are capable of initiating unintended acceleration. (All known defects of this nature have been subject to recalls). Once such an incident has begun, whether through human mistake or vehicle malfunction, it must be assumed that driver error resulting from panic, confusion, and perhaps unfamiliarity with the Audi often contributes to the severity of the incident, particularly if it lasts more than a few seconds.

8.5 ADDITIONAL RESEARCH

The following additional tests and research were in progress at the time of writing.

1. Experimental determination of the tolerances of various versions of the cruise control for high ambient temperatures and electromagnetic interference from sources such as the air-conditioner clutch and alternator diodes.
2. Empirical studies to determine the relationship between physical factors, such as the dimensions and forces of driver controls and accommodations, and pedal misapplication.

The reader is referred to *An Examination of Sudden Acceleration*, for further discussion of these research topics.

APPENDIX A

IDLE-STABILIZER VALVE

A.1. ELECTROMECHANICAL CHARACTERISTICS

Two idle bypass valves were obtained from Audi. One valve was disassembled to permit a more detailed examination of the internal mechanisms and to measure the stiffness of the torsional spring. (The torsional spring is used to return the valve to its nominal opening when power is turned off.) The second valve was used to measure the electromechanical characteristics of the windings.

The control unit adjusts the airflow by sending electrical signals to the stabilizer valve. The electrical signal consists of two 12 V square waves with different periods. Each square wave is sent to two armature field windings located 90° apart as shown in Figure A-1(a). These square waves are known as duty cycles. A sample of a single 28 percent duty cycle being sent to one armature field winding is shown in Figure A-1(b). The valve opening angle of the idle-stabilization valve is controlled by the equilibrium of the torques acting on the rotor. The three torque-contributing components are the torsional spring, Field Winding I, and Field Winding II. When no voltage is applied, the spring maintains the valve at a position of 10° from the fully closed position. Each field winding exerts a torque dependent on the direction and amount of voltage applied. These measurements provide the torque developed by the spring as a function of valve opening angle. The spring torque equation is:

[A.1]

$$T_s = K_s (\theta - 10) = 0.123(\theta - 10)$$

where T_s = torque of the spring (oz-in)
 K_s = spring constant (oz-in/degree)
 θ = angle valve displaced from just-closed position (degrees)

The winding torque equations are:

Field Winding I

[A.2]

$$T_1 = K_1 V_1 \sin(\theta - \theta_1) = (718)V_1 \sin(\theta - 159)$$

Field Winding II

[A.3]

$$T_2 = K_2 V_2 \sin(\theta - \theta_2) = (985)V_2 \sin(\theta + 115)$$

where $T_{\#}$ = torque of field winding (oz-in)
 $K_{\#}$ = winding constant (oz-in/volt)
 $V_{\#}$ = voltage applied (volt)
 θ = angle valve displaced (degrees)
 $\theta_{\#}$ = phase angle of winding (degrees relative to closed position)

The continuous curves shown in Figure A-2 show the correlation between the measured data and the characterization above. The symbols represent the measured data points and the lines are the characterizations.

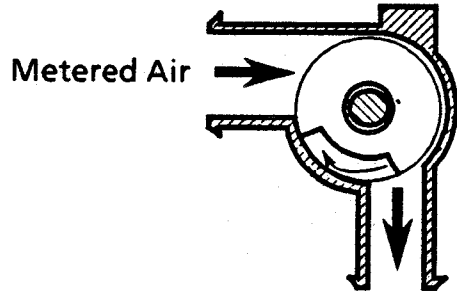
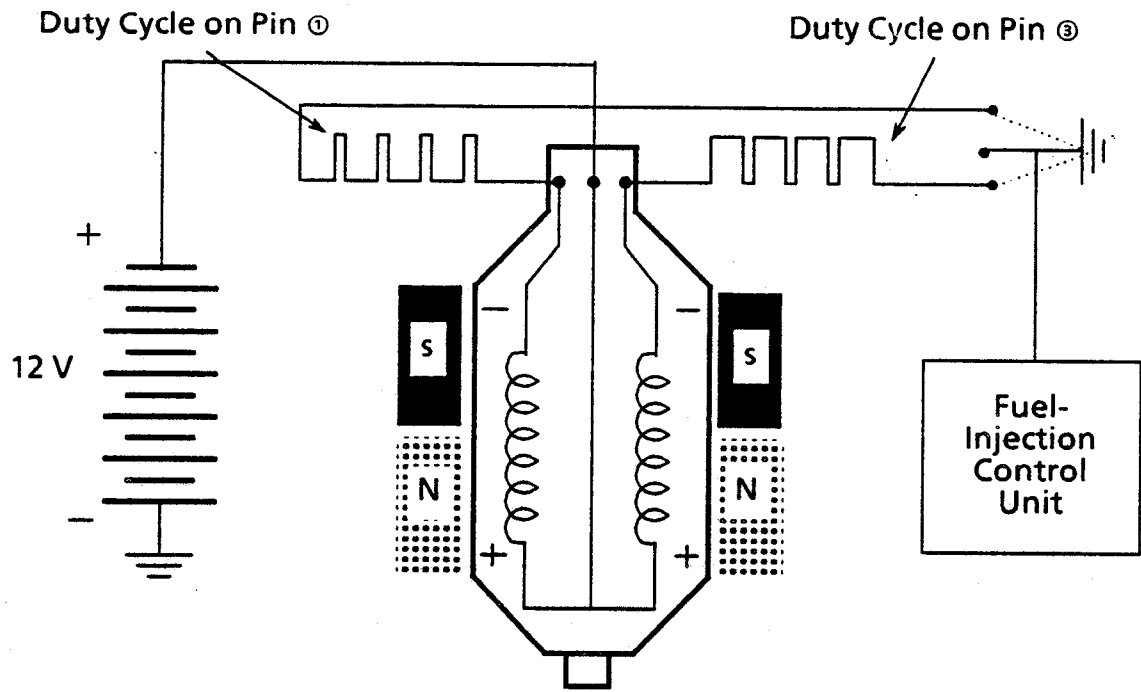

(a)

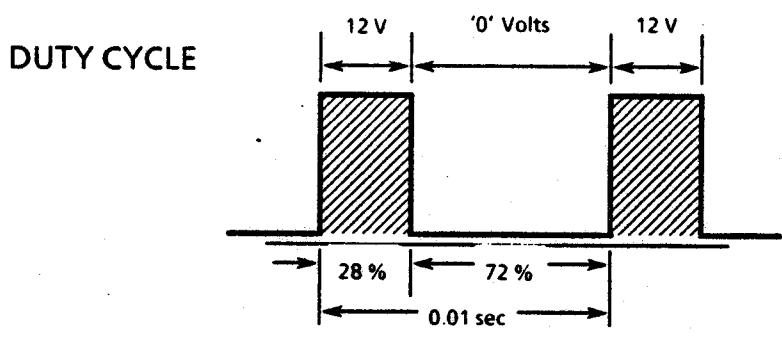

(b)

SOURCE: CIS-Electronic Fuel Injection Service Training Manual 1986, 21.

FIGURE A-1. IDLE-STABILIZER VALVE SCHEMATIC AND DUTY CYCLE

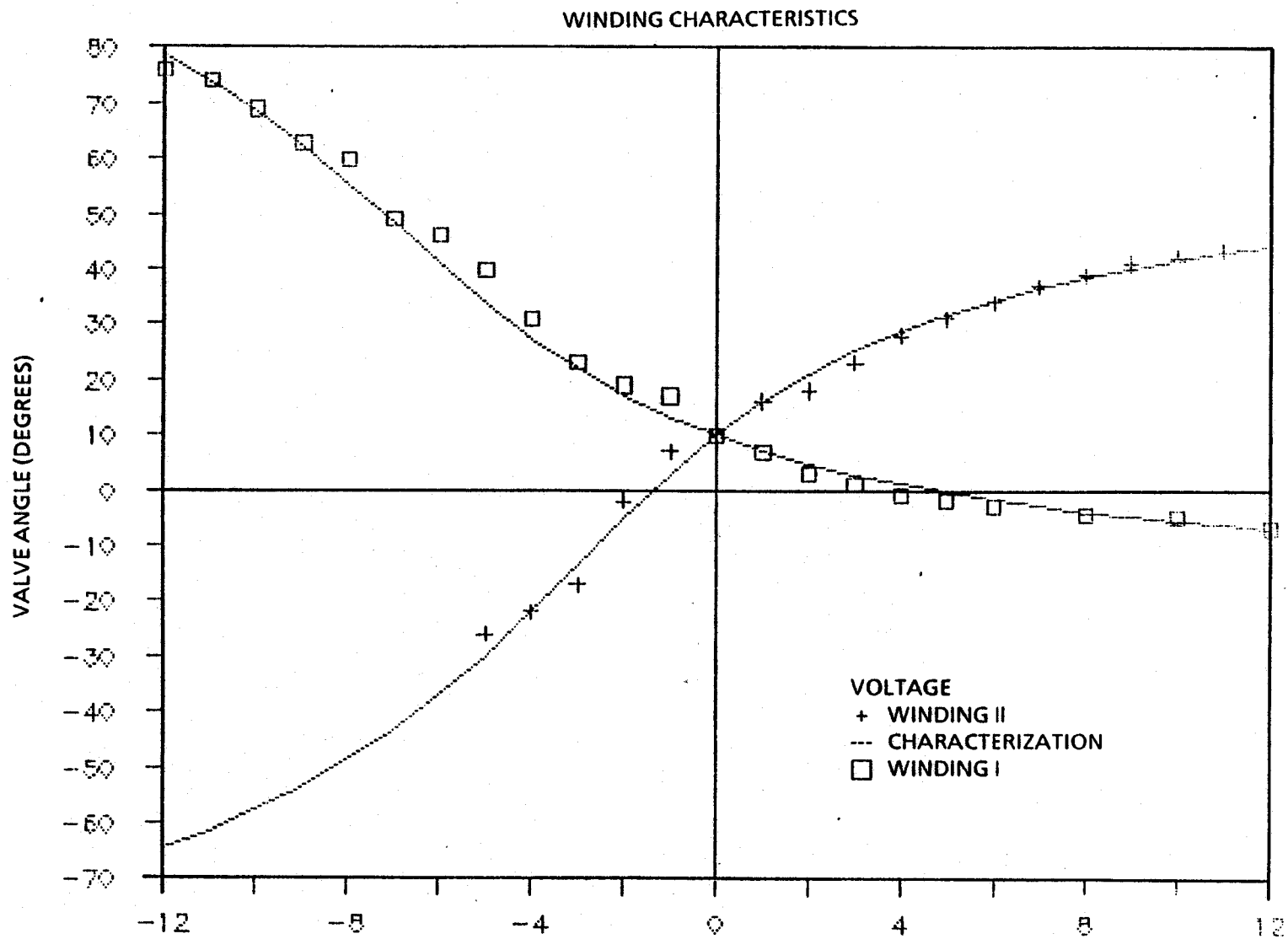

FIGURE A-2. ARMATURE FIELD WINDING CHARACTERISTICS MEASURED AND ESTIMATED

The general equation of motion for the valve is :

[A.4]

$$M = -T_s + T_1 + T_2 = I \frac{d^2(\theta)}{dt^2}$$

where

I = moment of inertia

and

[A.5]

$$V_T = V_1 + V_2 = 12 \text{ volts}$$

Voltages V_1 and V_2 are time-averaged voltages.

The torque-contributing components were combined to determine the angular displacement of the valve, keeping $V_1 + V_2 = 12$ V and a settled valve (i.e., not being commanded to a new position). The torques developed in the valve due to the airflow are not included in the equations since these torques are negligible compared to the winding torques.

The resulting valve equilibrium equation is:

[A.6]

$$M=0 = -K_s(\theta - 10) + K_1 V_1 \sin(\theta - \theta_1) + K_2 V_2 \sin(\theta - \theta_2)$$

The result plotted in Figure A-3 represents the opening angle of the valve as a function of the percent duty cycle on Winding I during normal operation. Measurements made to confirm these positions for the different duty cycles are shown as the symbols in Figure A-3. The characterizations of the torque-contributing components were used to establish the relationship between the torque acting on the valve armature and the valve angular displacement. Under normal operation, the equilibrium positions range between -7° to the fully open position of 44° . When the valve reaches the 44° position, further opening does not increase the airflow. However, if the valve goes beyond the -36° position (past fully closed), the valve begins to increase the airflow again.

The control unit supplies 12 V to the center pin and adjusts the average current sent to the valve armature by alternately grounding either pin 1 or pin 3. The time period that the computer grounds the pins defines the duty cycle. Pins 1 and 3 are connected to brushes that run against a segmented commutator of the armature. Figure A-4 shows the orientation of the valve's electrical components, and the sign and naming conventions. A diagram of the electrical circuit within the armature for normal operation is shown in Figure A-5(a).

The arrows in Figure A-5(b) represent the direction of current flow under normal operation. A 12 V power is supplied to the positive collector segment and the pins 1 and 3 are grounded by the control unit to complete the circuit. The grounding of pin 3 is the command to open the valve fully. Figure A-6 shows the torque acting on the valve armature as a function of valve opening angle for the fully open command. This curve shows that if the valve was at the 10° equilibrium position and received this command, a torque of 9.6 oz-in would be applied to the armature with a final settling position of 44° . The grounding of pin 1 is the command to fully close the valve. Figure A-7 shows the torque acting on the valve armature as a function of valve opening angle for the fully closing command. This curve shows that if the valve was at the 10° equilibrium position and received this command, a torque of -4.5 oz-in would be applied to the armature with a final settling position of -7° . The major discontinuities in these curves at the 94 and -26° positions result from the brushes contacting the adjacent commutator segments.

The armature is not mechanically restricted to 120° of travel so the brushes can contact adjacent commutator segments. Since the valve may overshoot the position commanded by the controller, there is a potential for the armature to overrun the commutator segment. If this were to occur, the current in the windings would change direction and, in turn, reverse the torque applied.

NEUTRAL POSITION

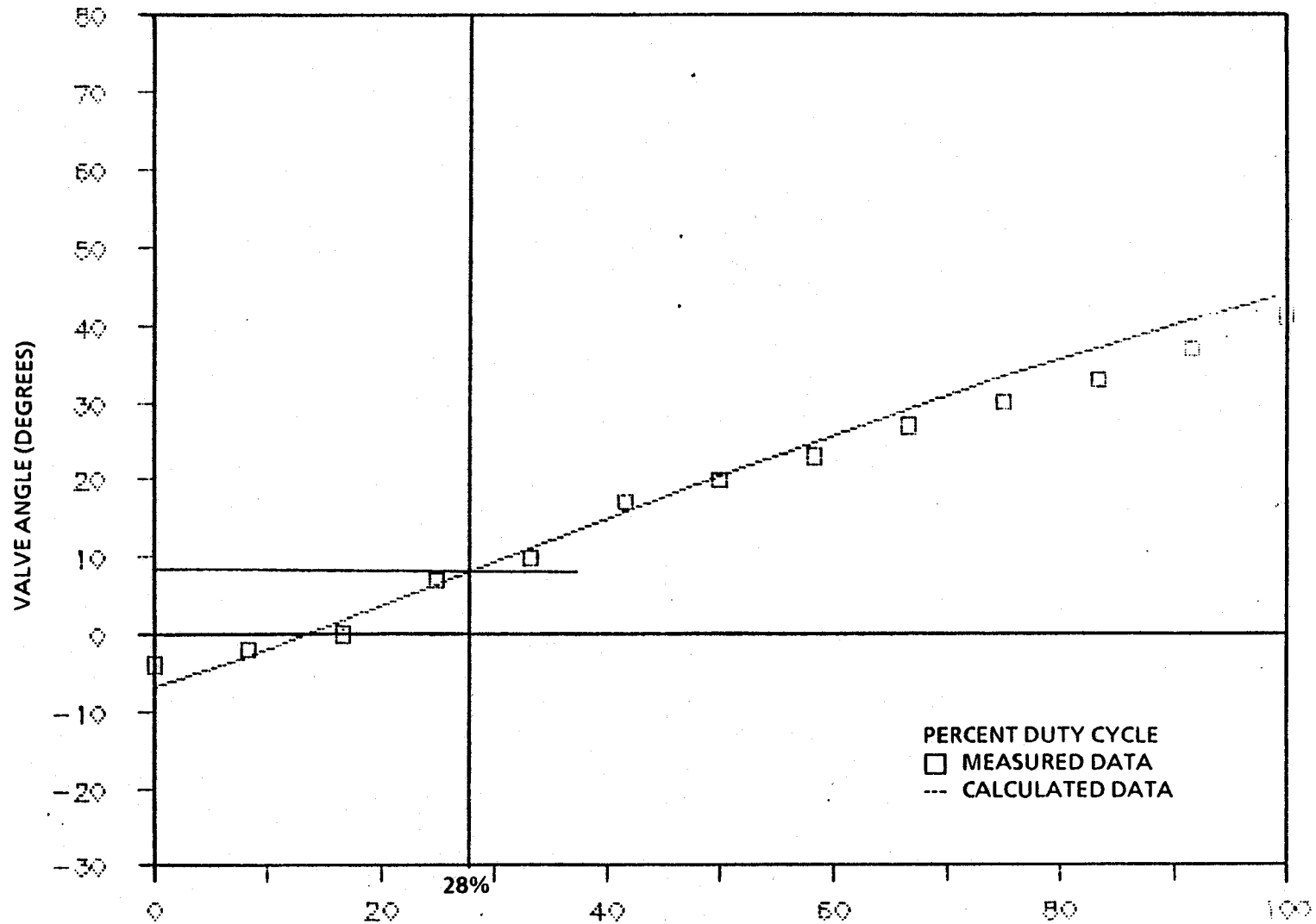

A-5

FIGURE A-3. OPENING ANGLE OF VALVE AS A FUNCTION OF PERCENT DUTY CYCLE ON WINDING I DURING NORMAL OPERATION

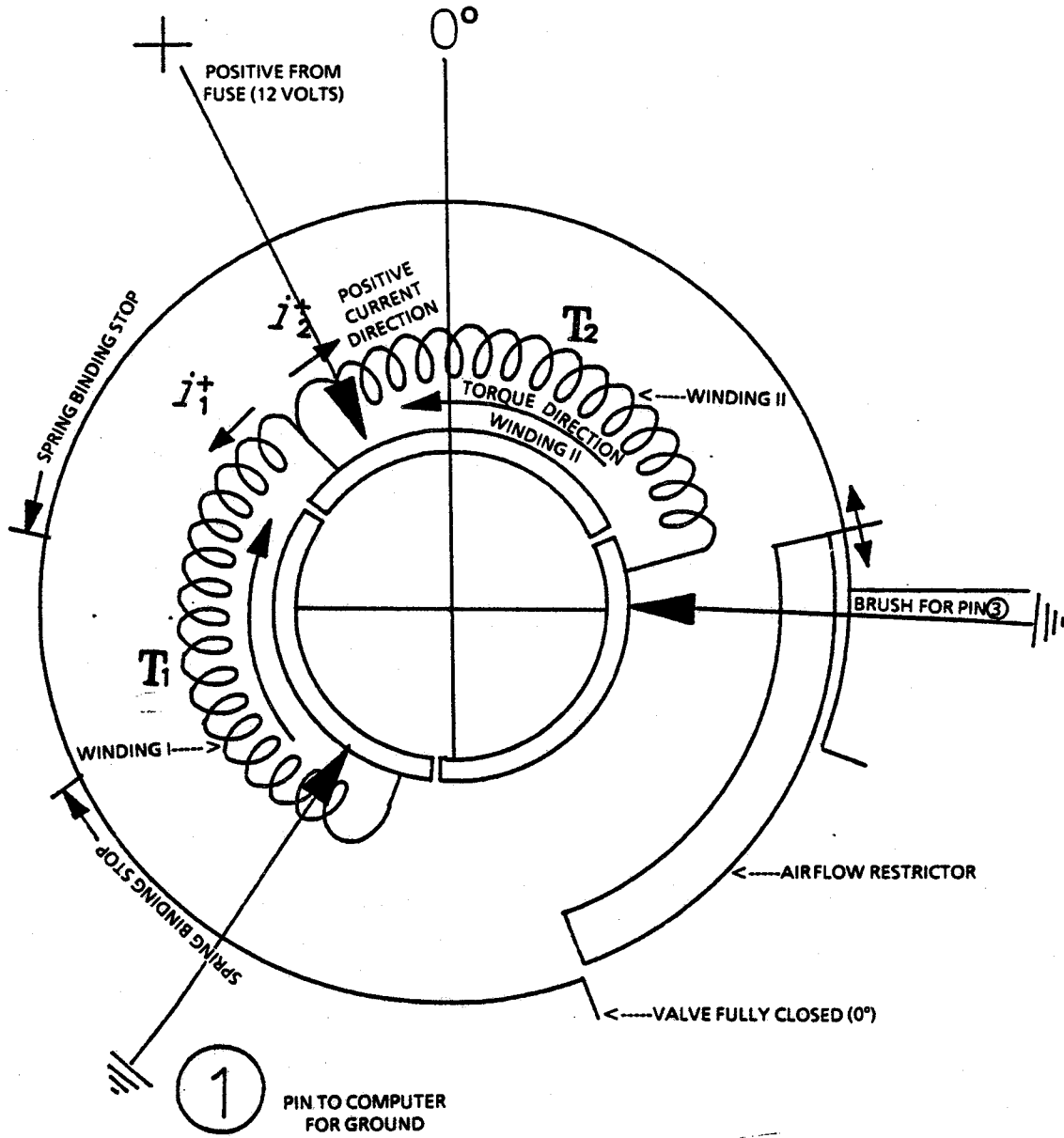

3

FIGURE A-4. ORIENTATION OF VALVE COMPONENTS AND SIGN CONVENTIONS

NORMAL

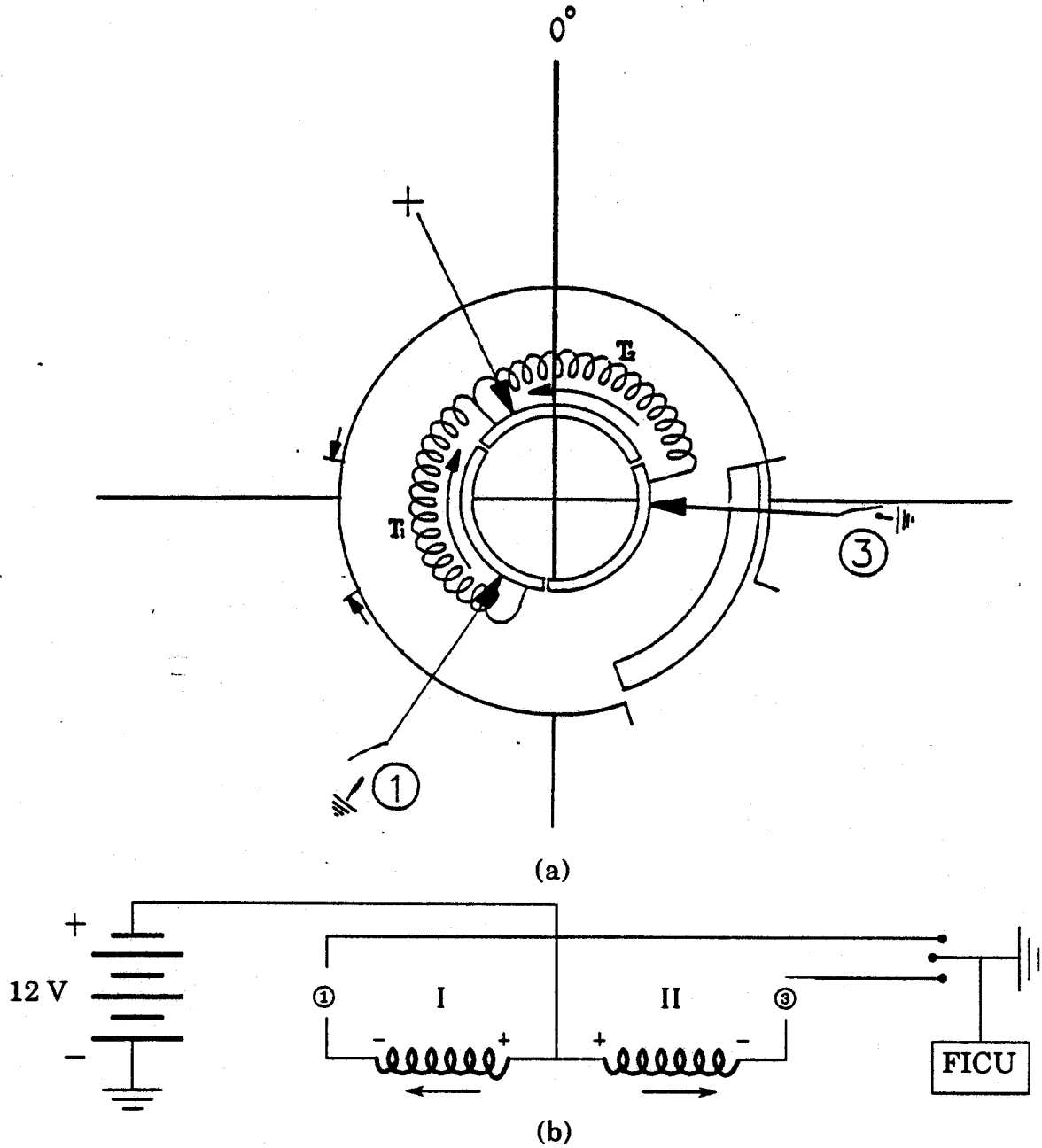

FIGURE A-5. IDLE-STABILIZER VALVE UNDER NORMAL OPERATION

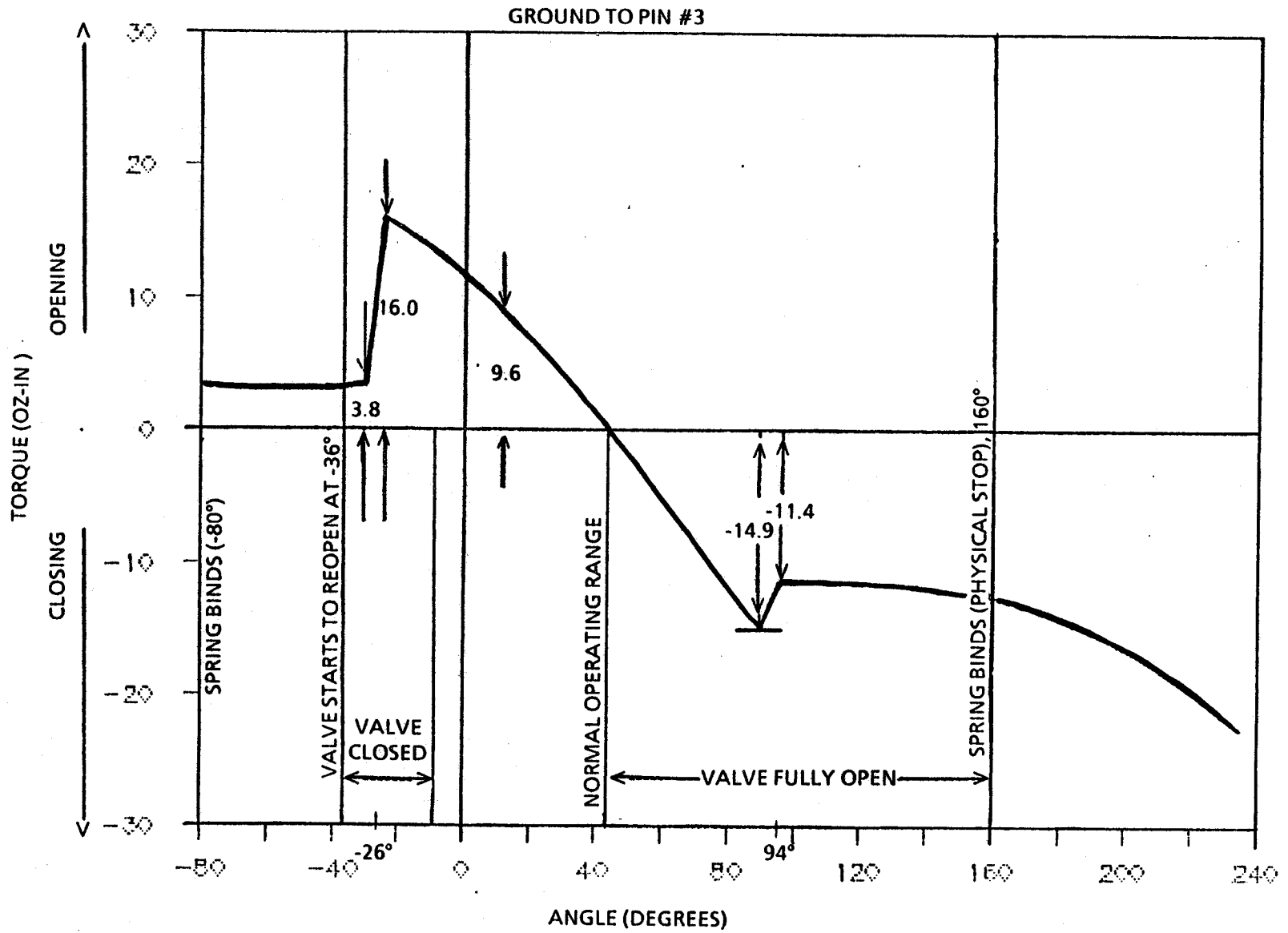

FIGURE A-6. TORQUE ON ARMATURE VERSUS VALVE OPENING ANGLE FOR THE COMMAND TO FULLY OPEN

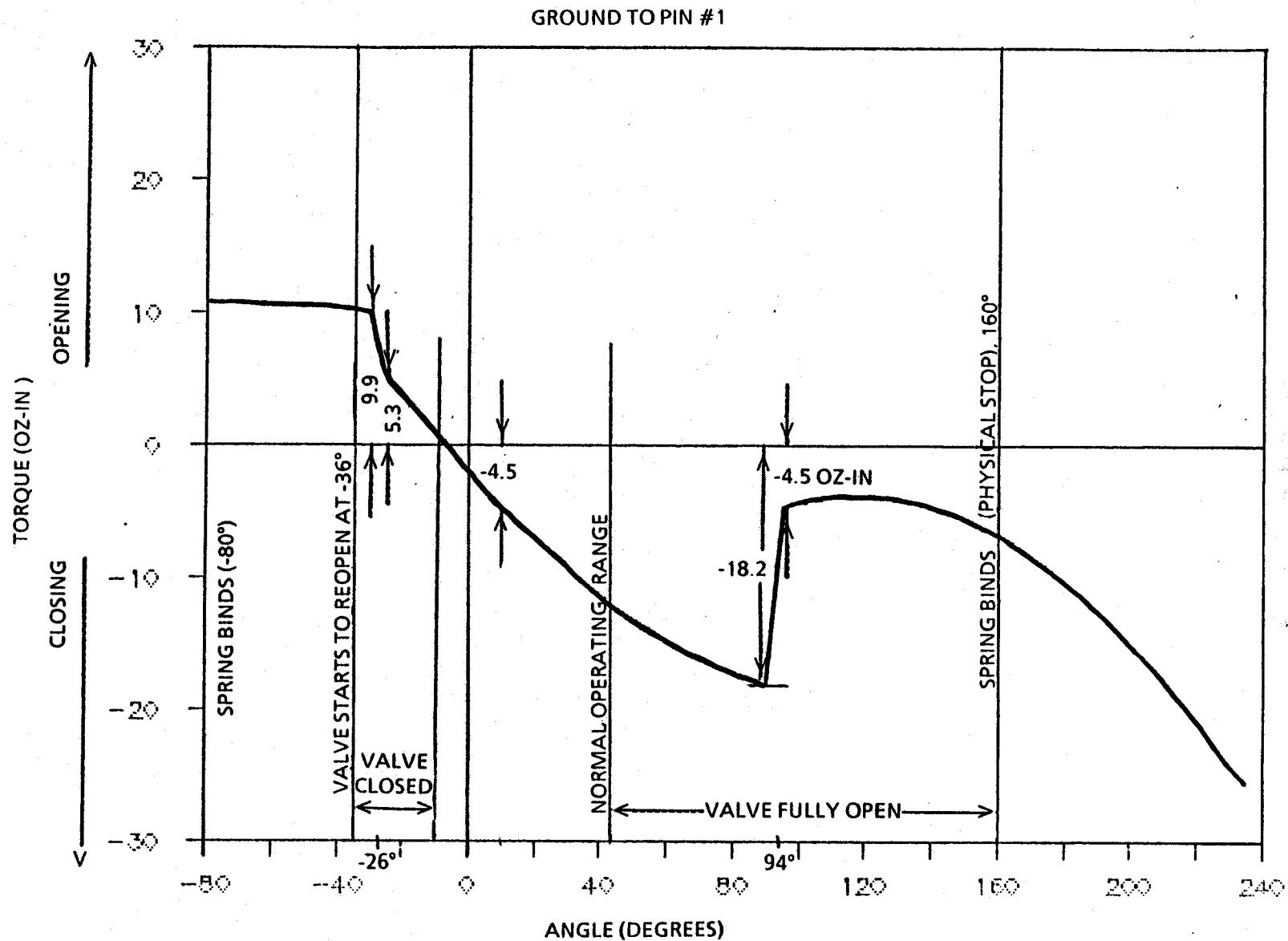

FIGURE A-7. TORQUE ON ARMATURE VERSUS VALVE OPENING ANGLE FOR THE COMMAND TO FULLY CLOSE

The two possible overrun positions are the overrun open and overrun closed positions. In Figure A-8 the electrical circuit is shown for the case just before the overrun open condition occurs ($0 < 94^\circ$). The current flow is the same as under normal operation. When the overrun open condition occurs ($0 > 94^\circ$), the electrical circuit in the armature is affected as shown in Figure A-9(a).

As shown in Figure A-9(b), the current reverses direction in Field Winding II. This change in direction reverses the direction of the torque applied. The current in Field Winding I is in the same direction as normal operation. This torque reversal causes the torque in the closing direction to decrease. If the computer should send a command to fully open (pin 3 being grounded, 100 percent duty cycle) while the valve is in the overrun open position, the torque changes from -14.9 oz-in to -11.4 oz-in, as shown in Figure A-6. In the case of a command to fully close (pin 1 being grounded, 0 percent duty cycle), the closing torque would change from -18.2 oz-in to -4.5 oz-in, as shown in Figure A-7.

For the cases of overrunning in the closed position ($0 < -26^\circ$), the electrical circuit in the armature is affected as shown in Figure A-10. As the current changes direction in Field Winding I, the torque changes direction. The change in direction increases the opening torque. For the fully closed command, the opening torque changes from 5.3 oz-in to 9.9 oz-in (Figure A-7). For the fully open command, the opening torque decreases from 16.0 oz-in to 3.8 oz-in (Figure A-6).

A.2 TRANSIENT RESPONSE

When the valve responds to a change in duty cycle, the valve will overshoot the equilibrium position by an amount approximately equal to the initial displacement error. Figure A-11 shows how a simple spring mass system would overshoot in response to an initial displacement. The equilibrium position is the position to which the valve would settle if no other duty cycle was encountered. If the duty cycle was changed suddenly to command a new valve opening angle, the valve would overshoot the new equilibrium position by an angle approximately equal to the difference between the old angle and the new position. If the engine's change in RPM response time is slow, the difference between the new and old angle can become large and increase the possibility of overrun conditions.

A.3 POTENTIAL FAILURE MECHANISMS

It was necessary to determine if there was a mechanical sticking that would hold the valve in the fully open position. Mechanical sticking could be caused by either a bearing failure or a brush commutator failure. In the event of a bearing failure, the valve opens fully and remains open because of the binding of the bearing on the shaft. In the event of the brush commutator failure, the brush would attach itself to the current collector. If the valve was under the overrun open condition and a mechanical-resisting torque of 4.5 oz-in existed, the closing duty cycle would not close the valve. The valve would remain above the 94° position as long as the closing duty cycle is being sent. Reversibility of this type of failure is very low. Under both of these mechanical failures the valve would not function properly and physical evidence of a defective valve would remain. If the valve was in the overrun open position and all components functioned properly, the valve would always return to the equilibrium position.

The idle-stabilizer valve could possibly fail if the commutator developed a dead spot and caused an intermittent opening of the circuit. This intermittent opening would cause a large oscillation from a fully closed to a fully open position. Such continuous oscillation would produce engine surging and might also produce a fatigue failure of the spring.

If the spring was to fail due to large oscillations, the valve would still operate. Without the resisting torque of the spring the valve would respond faster to the signals present and have a greater tendency to overrun the commutator. Within the normal range the valve characteristics are similar to normal

JUST BEFORE OVERRUN OPEN ($\theta < 94^\circ$)

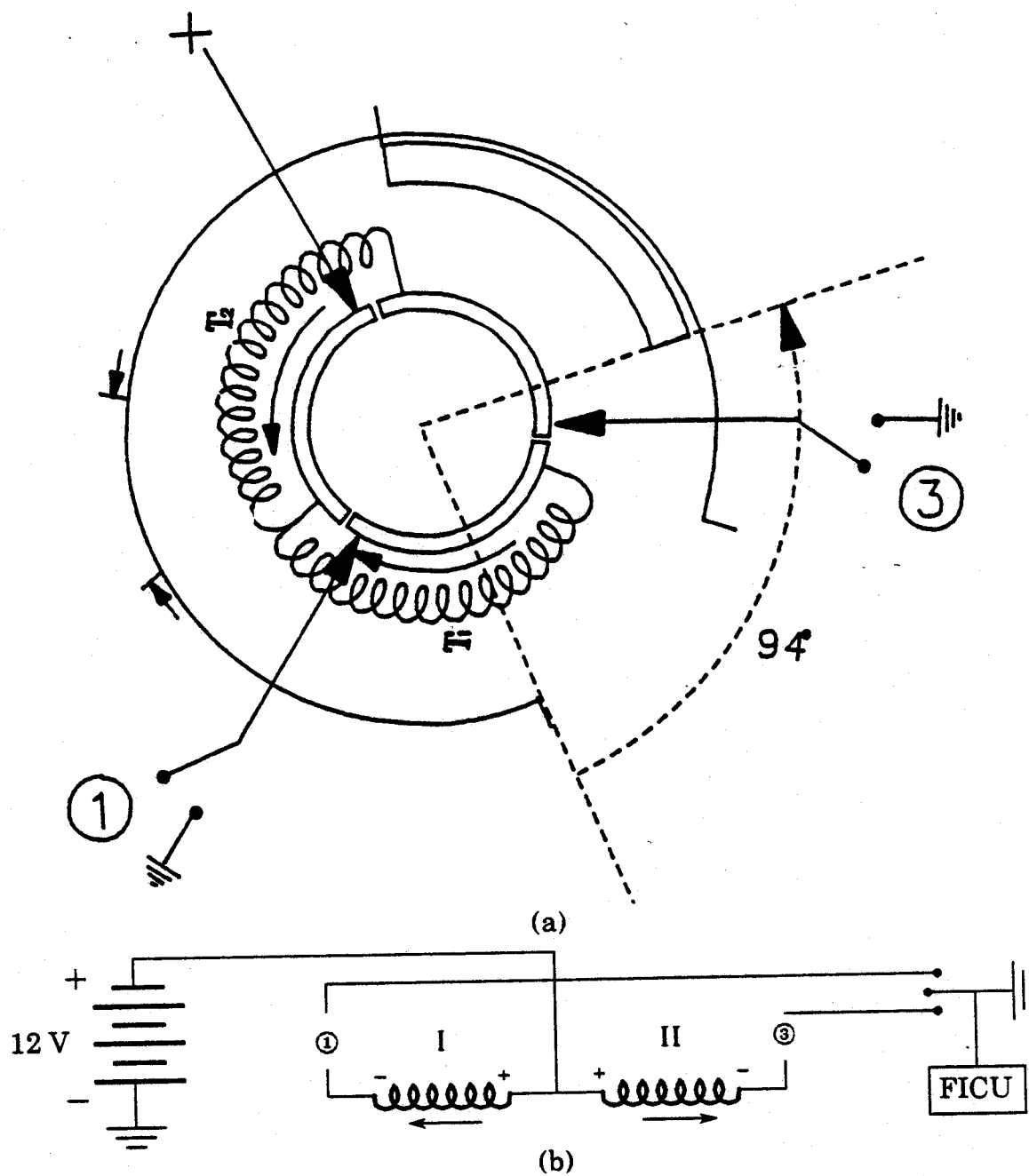

FIGURE A-8. IDLE-STABILIZER VALVE JUST BEFORE THE OVERRUN OPEN POSITION OCCURS

OVERRUN OPEN

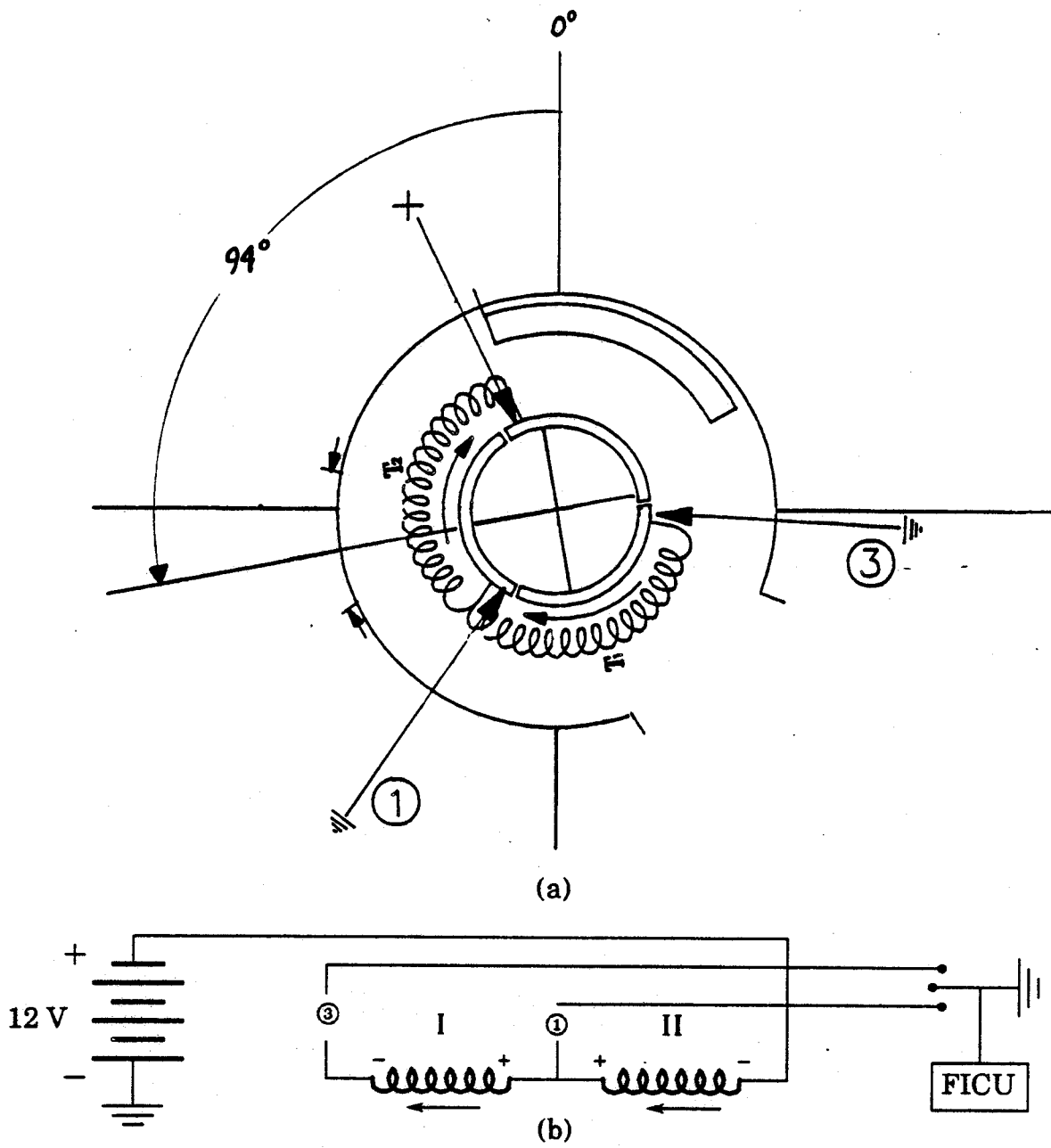

FIGURE A-9. IDLE-STABILIZER VALVE UNDER OVERRUN OPEN OPERATION

OVERRUN CLOSED

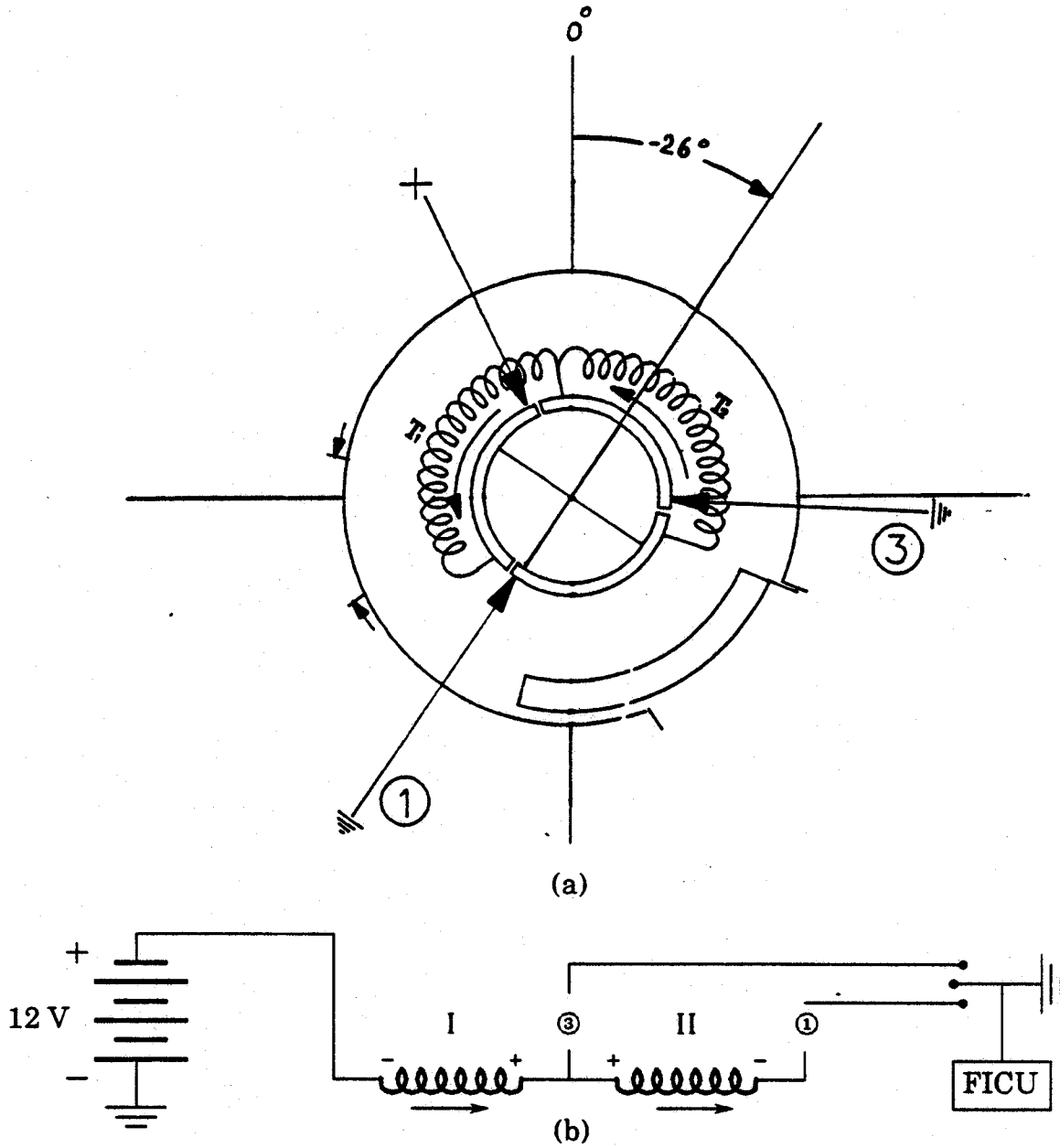

FIGURE A-10. IDLE-STABILIZER VALVE UNDER OVERRUN CLOSED OPERATION

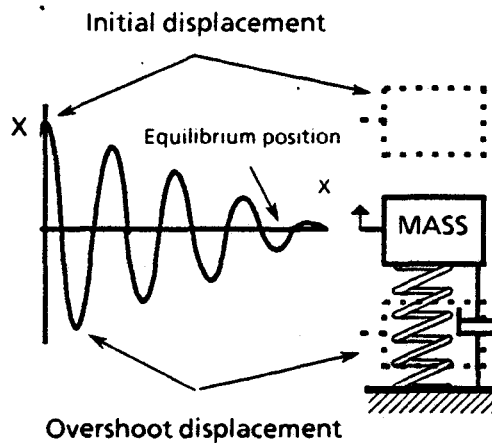

FIGURE A-11. SIMPLE SPRING MASS SYSTEM

operation. Figure A-12 shows the valve equilibrium opening angle as a function of duty cycle with the spring broken and with normal operation.

Figure A-13 illustrates the condition where the valve is commanded to fully open and the spring is broken. If the valve started at the 10° equilibrium position and received this command, the initial torque would be 9.6 oz-in. In this case, the valve would overshoot the commutator ($\theta > 94^\circ$) and the closing torque would reduce from -4.8 oz-in to -1.0 oz-in. If the valve continued past the 104° position, the torque would become positive and cause the valve to open even further.

Figure A-14 shows the condition where the valve is commanded to fully close and the spring is broken. If the valve started above the 94° equilibrium position and received the command to close, the closing torque of -8.3 oz-in would change to an opening torque of 6.0 oz-in. This reversal of sign would cause the valve to continue to open even with a closing signal. If the spring was broken or defective and the valve was in the overrun condition, a normal closing signal would continue to open the valve. If the power was shut off after an overrun condition and the valve drifted to less than 94° , the valve would return to the broken spring operation when the power was turned on.

A broken spring in the valve would not hamper the performance of either the vehicle or the valve. The engine RPM might surge to a greater extent than normal, but this might not seem out of the ordinary. If the valve was tested according to the Audi Factory Repair Manual, the results could show normal valve operation. The test checks the engine RPM at the 28 percent duty cycle. As shown in Figure A-12, at the testing location of 28 percent, the difference in valve angle with and without the spring is about 2° .

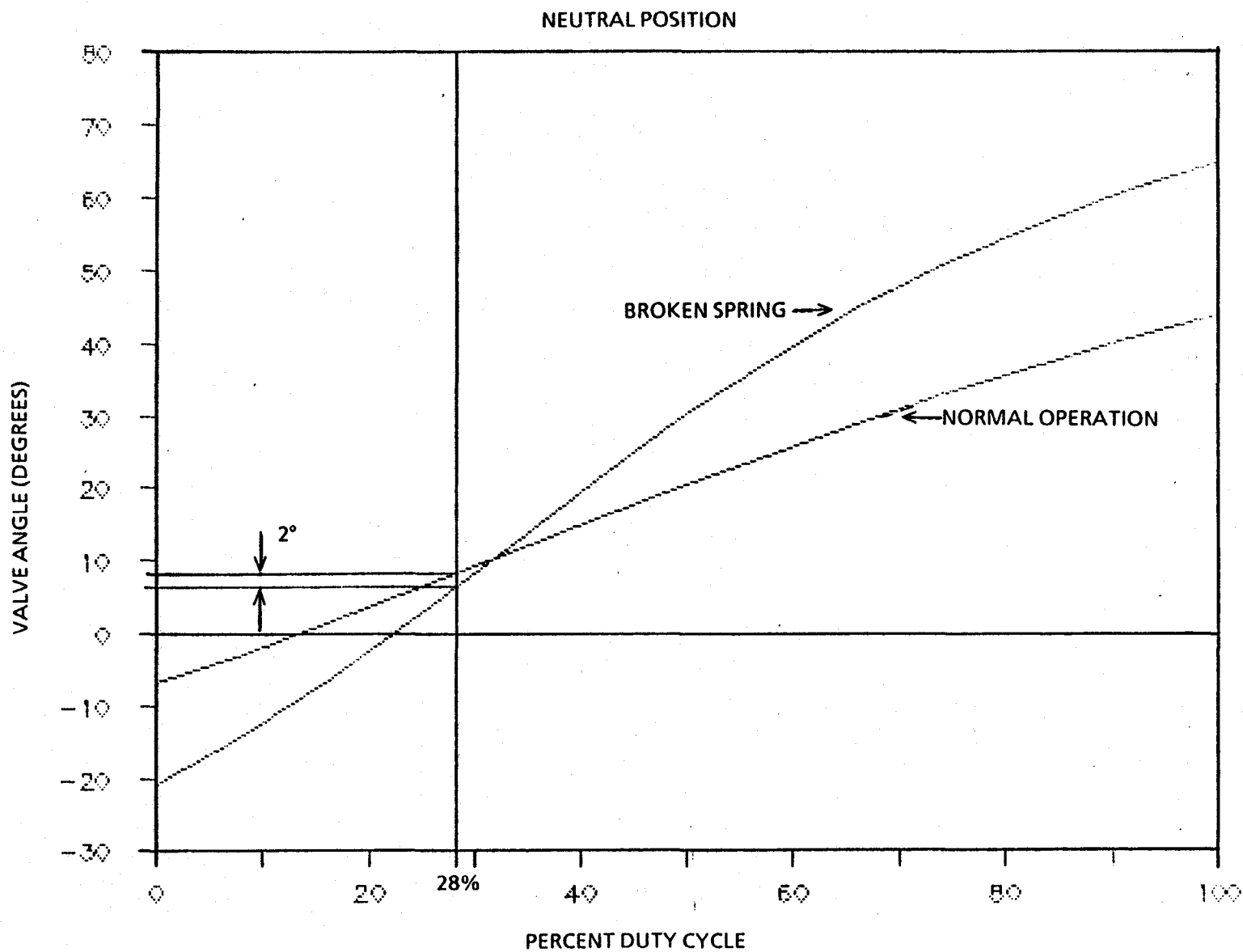

FIGURE A-12. OPENING ANGLE OF VALVE AS A FUNCTION OF PERCENT DUTY CYCLE ON WINDING I DURING NORMAL AND BROKEN SPRING OPERATION

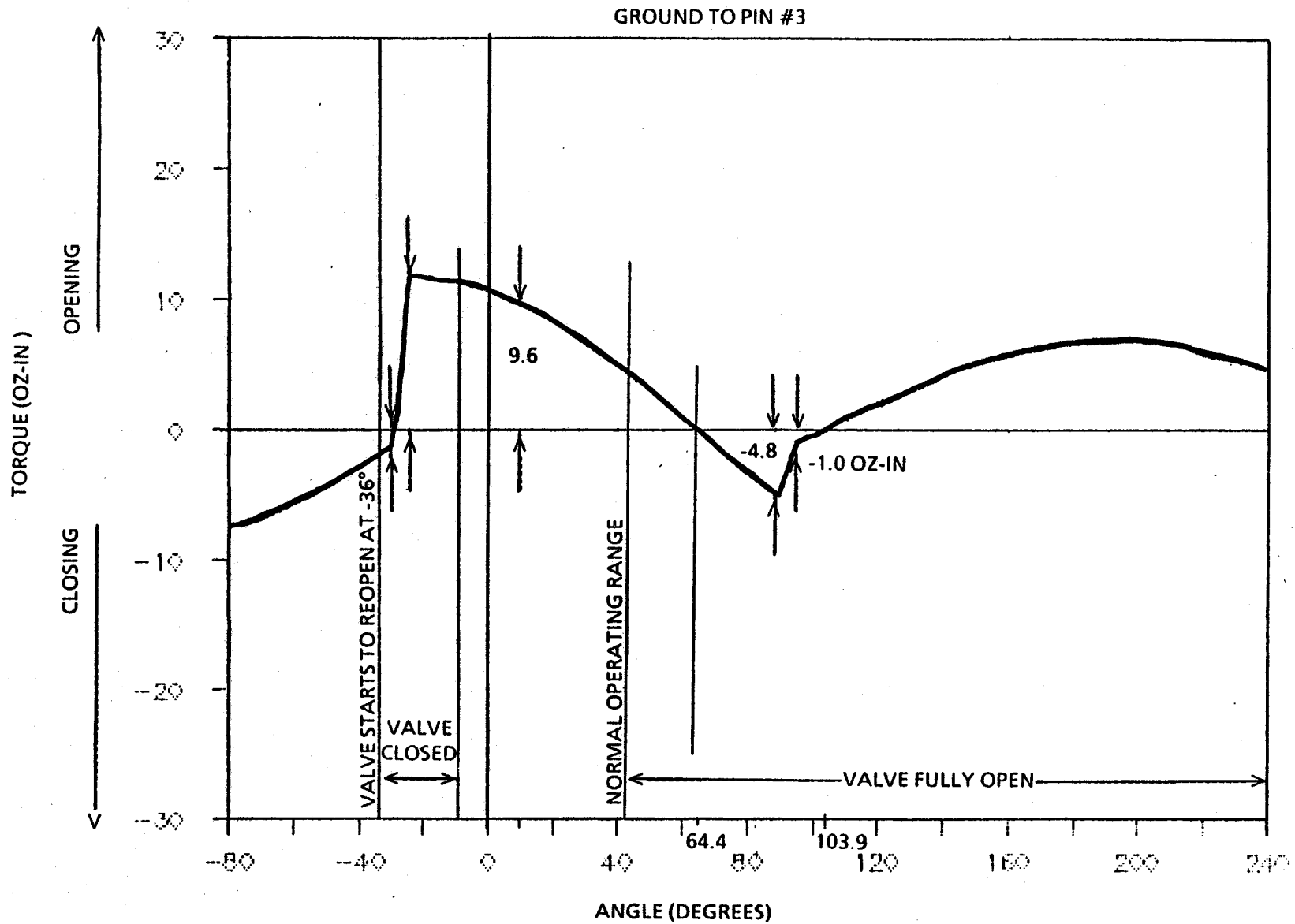

FIGURE A-13. TORQUE ON ARMATURE VERSUS VALVE OPENING ANGLE FOR THE COMMAND TO FULLY OPEN WITH SPRING BROKEN

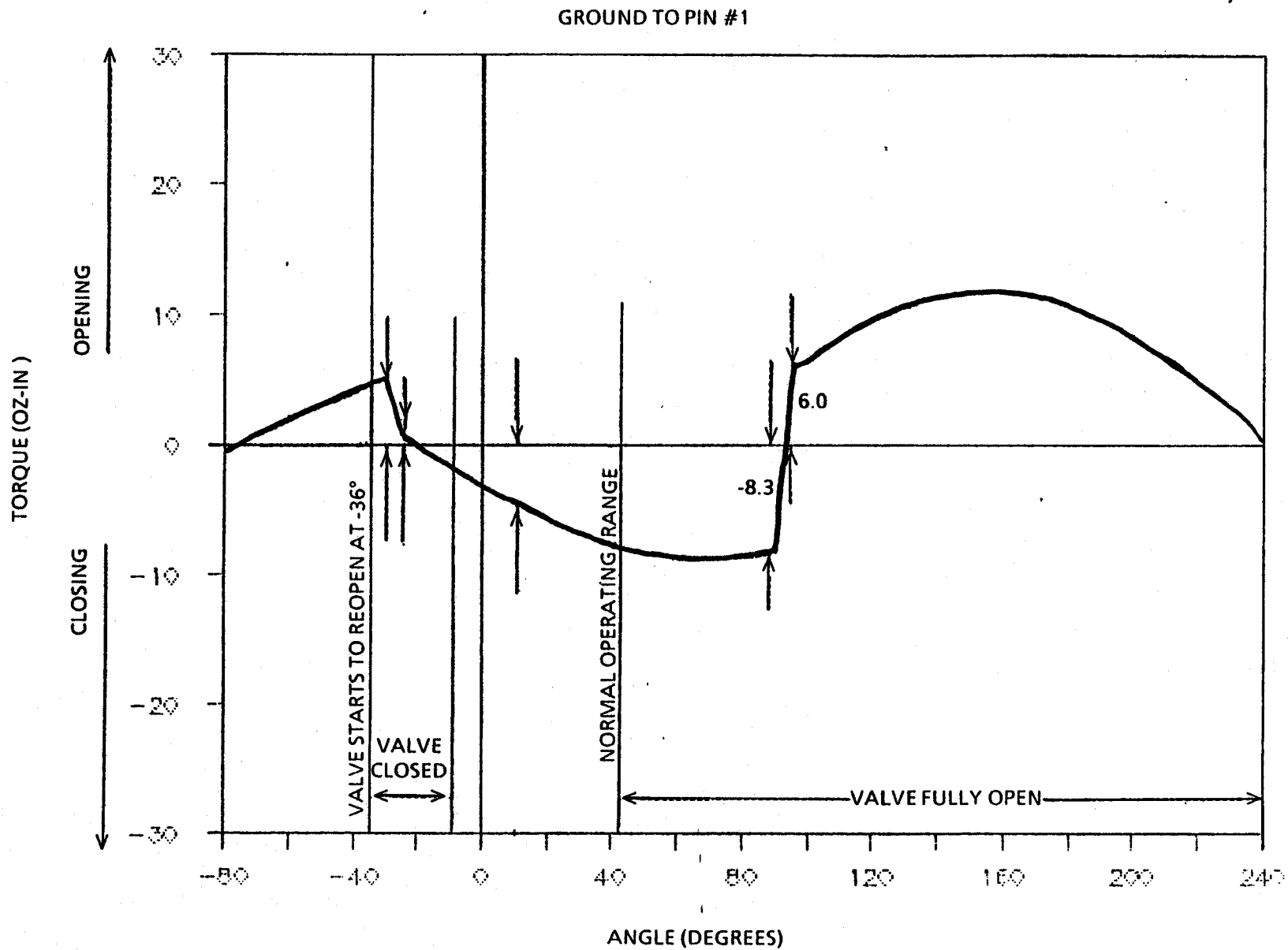

FIGURE A-14. TORQUE ON ARMATURE VERSUS VALVE OPENING ANGLE FOR THE COMMAND TO FULLY CLOSE WITH SPRING BROKEN

APPENDIX B
AUDI TEST DATA

Appendix B graphs are VWOA test data extracted from correspondence
between NHTSA and VWOA.

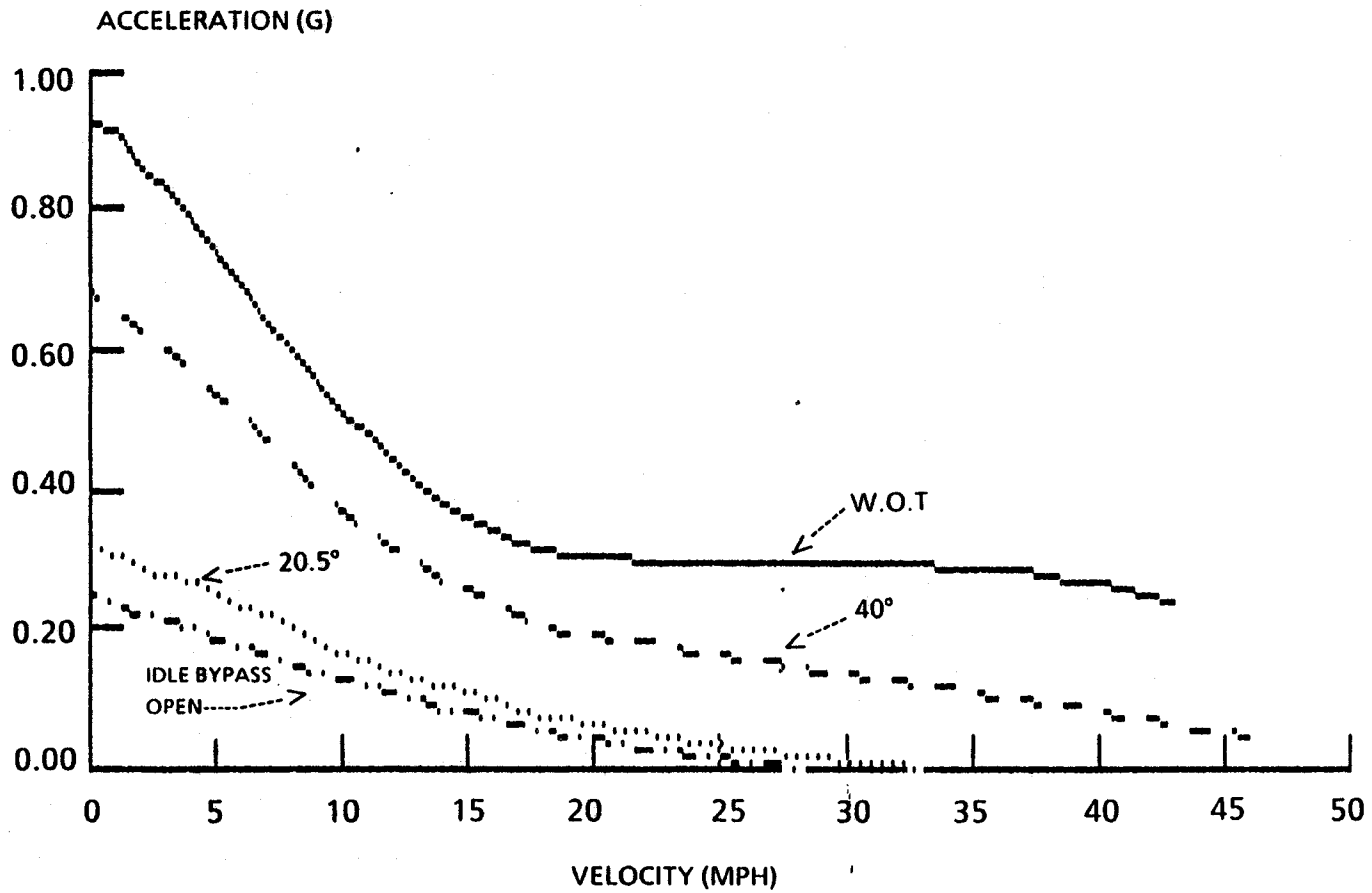

FIGURE B-1. 1986 AUDI 5000, REVERSE GEAR ACCELERATION (G) AT DIFFERENT THROTTLE ANGLES

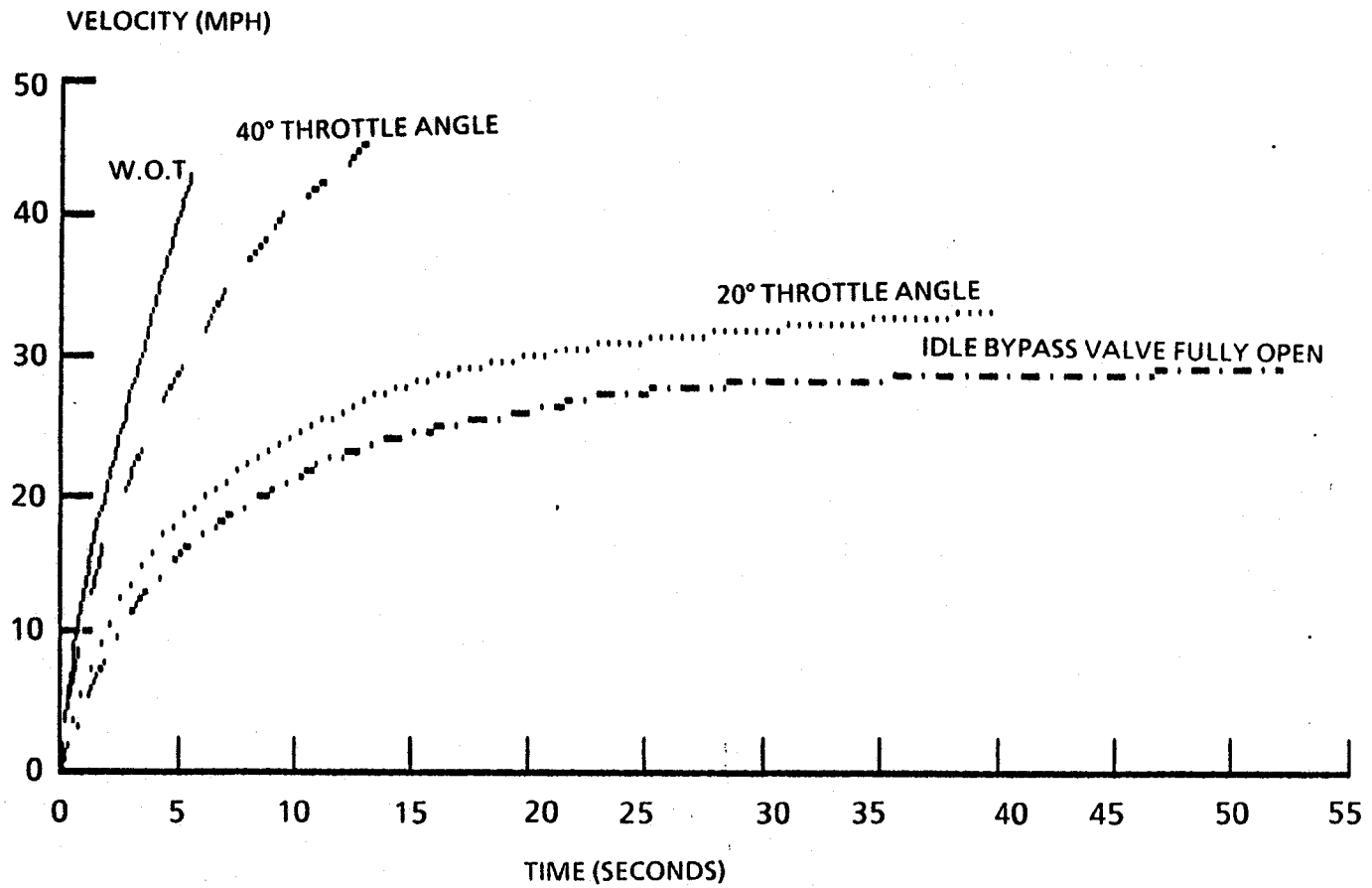

FIGURE B-2. 1986 AUDI 5000, REVERSE GEAR VELOCITY (MPH)/TIME

B-4

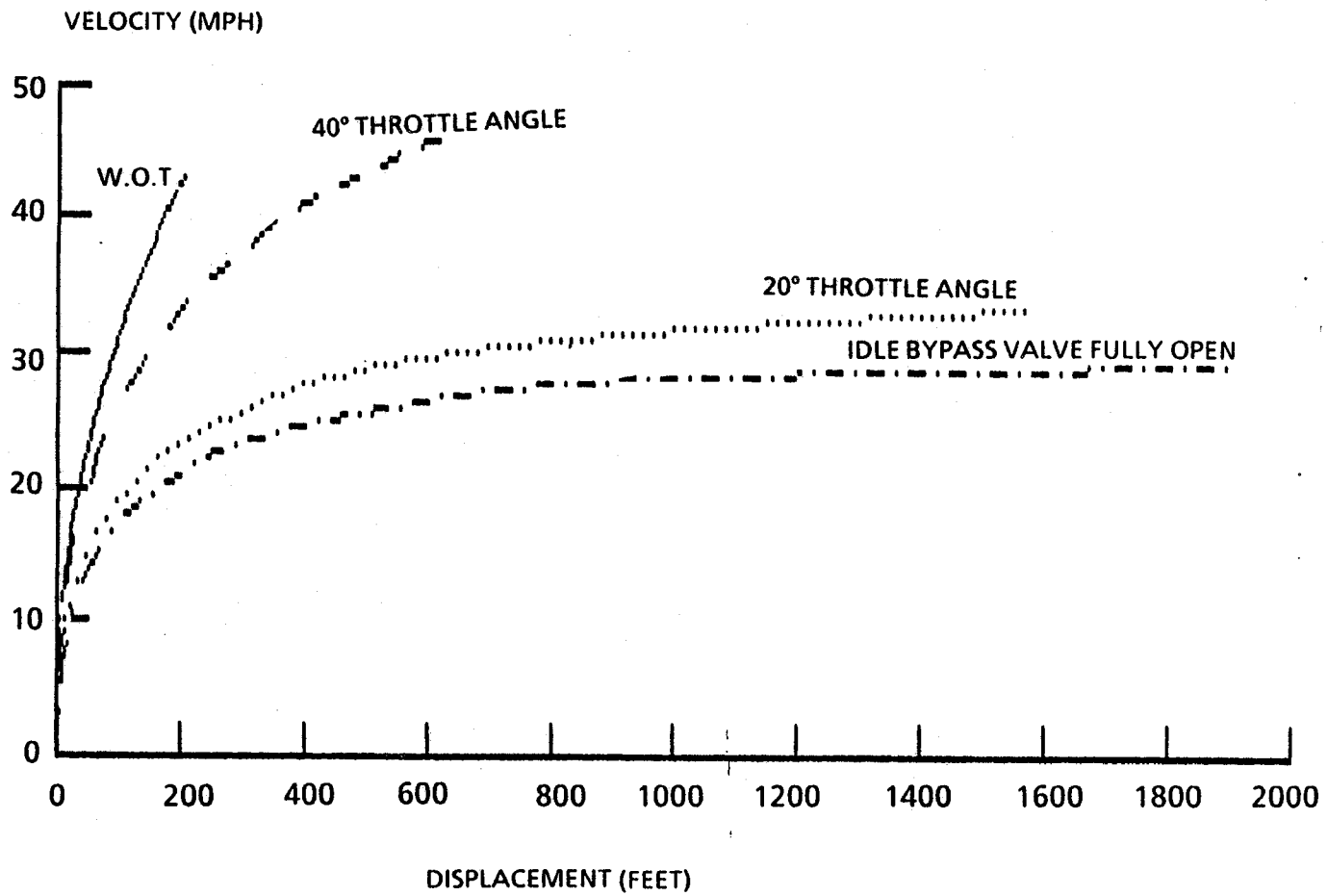

FIGURE B-3. 1986 AUDI 5000, REVERSE GEAR VELOCITY (MPH)/DISPLACEMENT

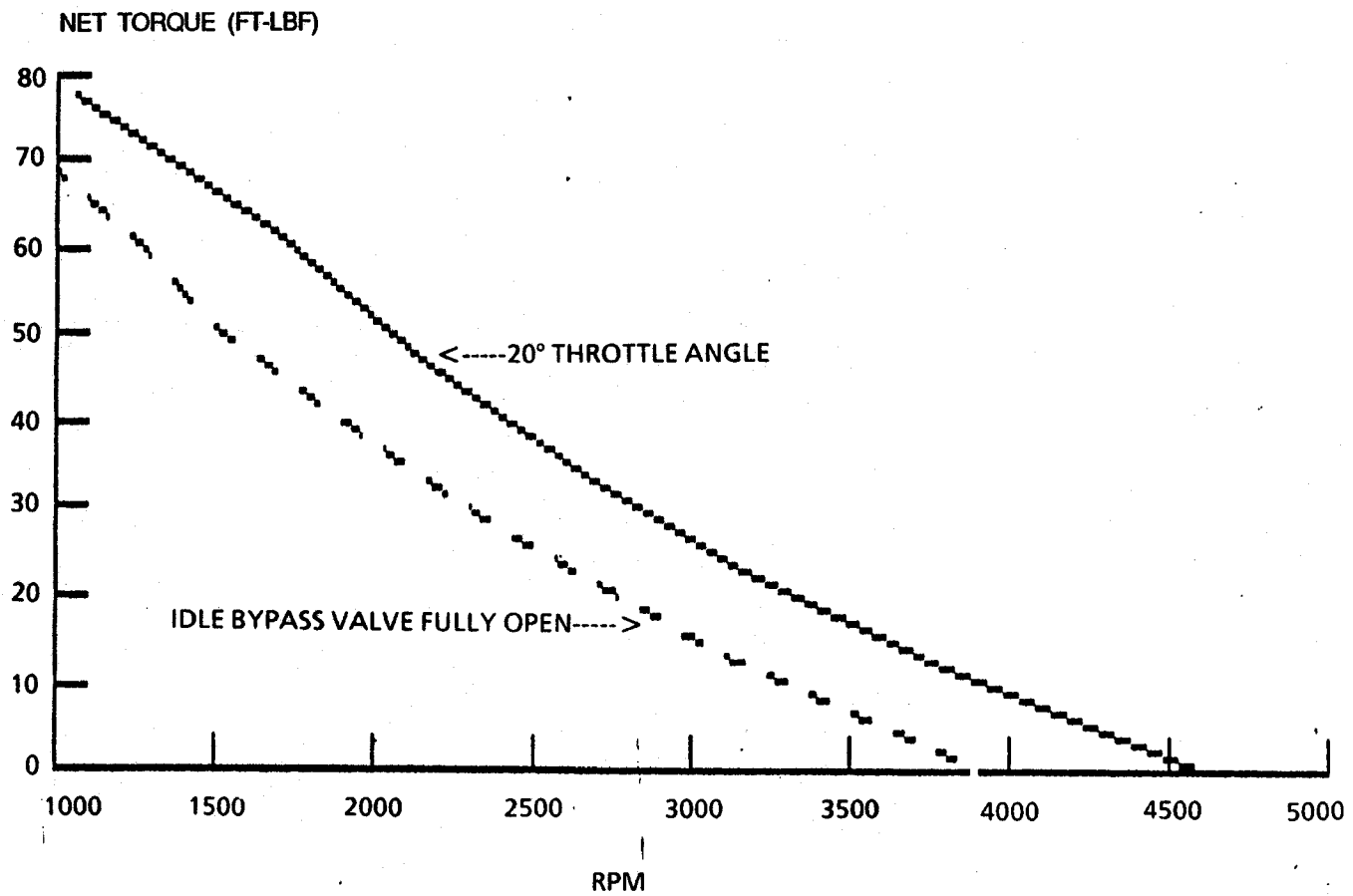

FIGURE B-4. NET ENGINE TORQUE (WARM)

TORQUE TURBINE/TORQUE PUMP

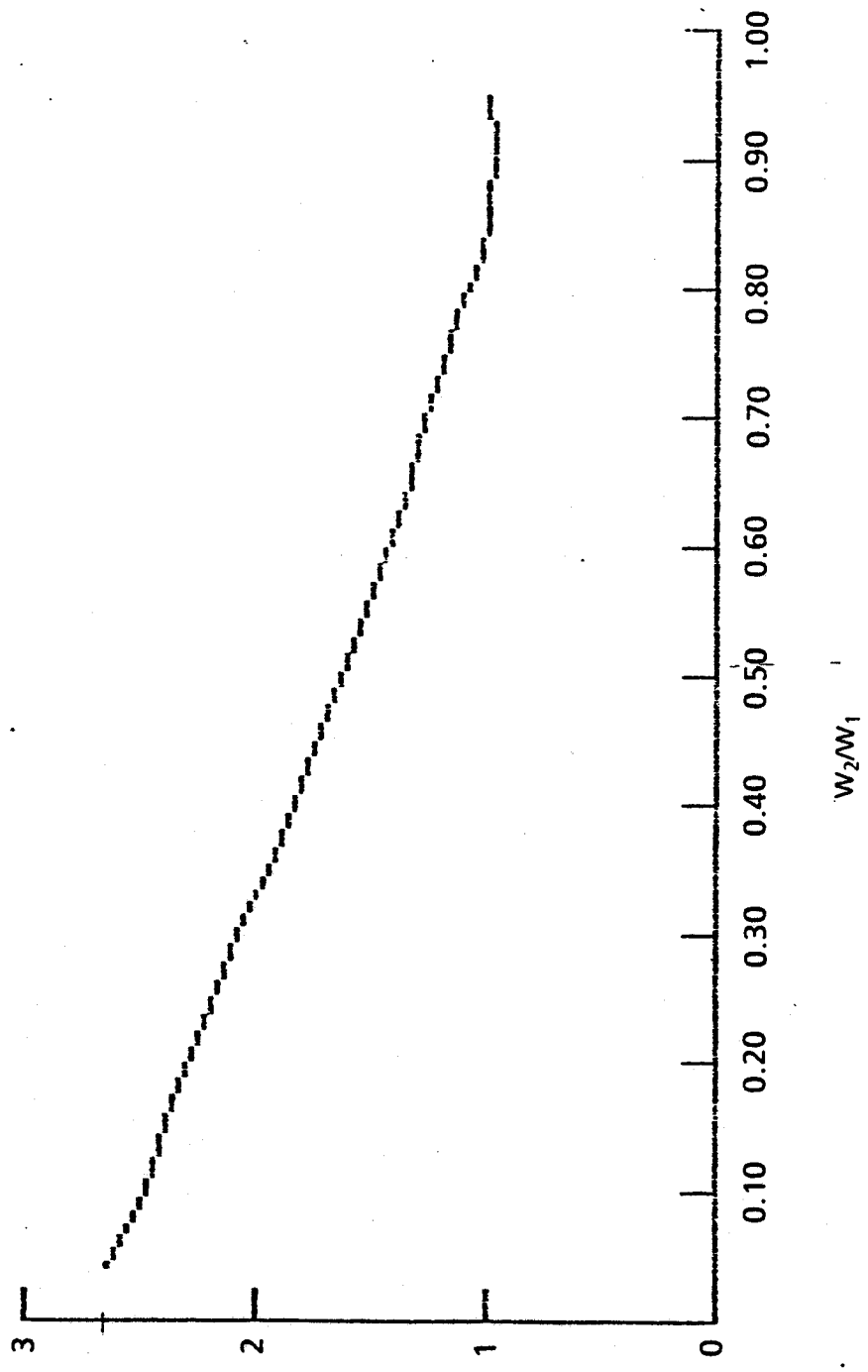

FIGURE B-5. TRANSMISSION TORQUE RATIO

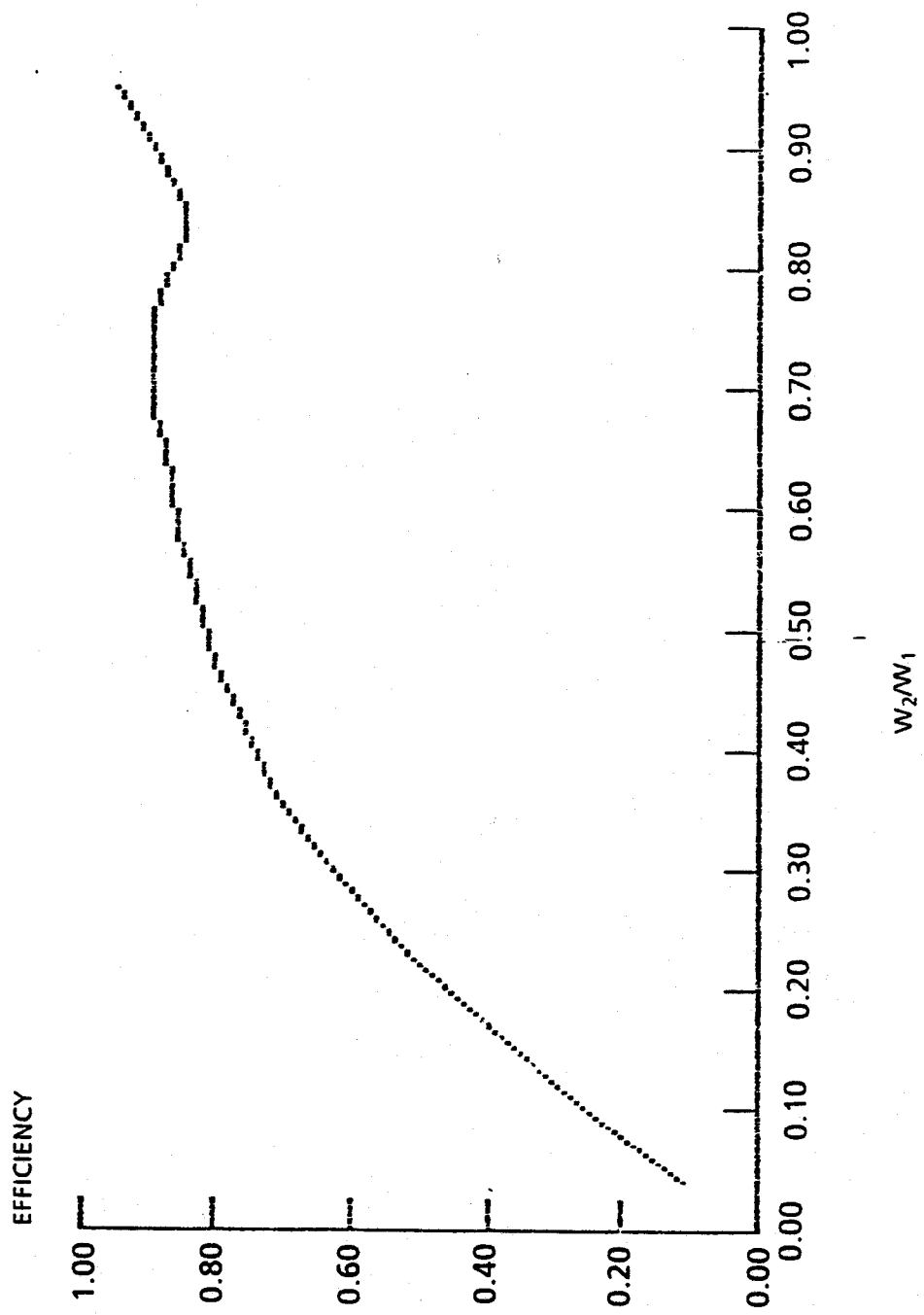

FIGURE B-6. TRANSMISSION EFFICIENCY

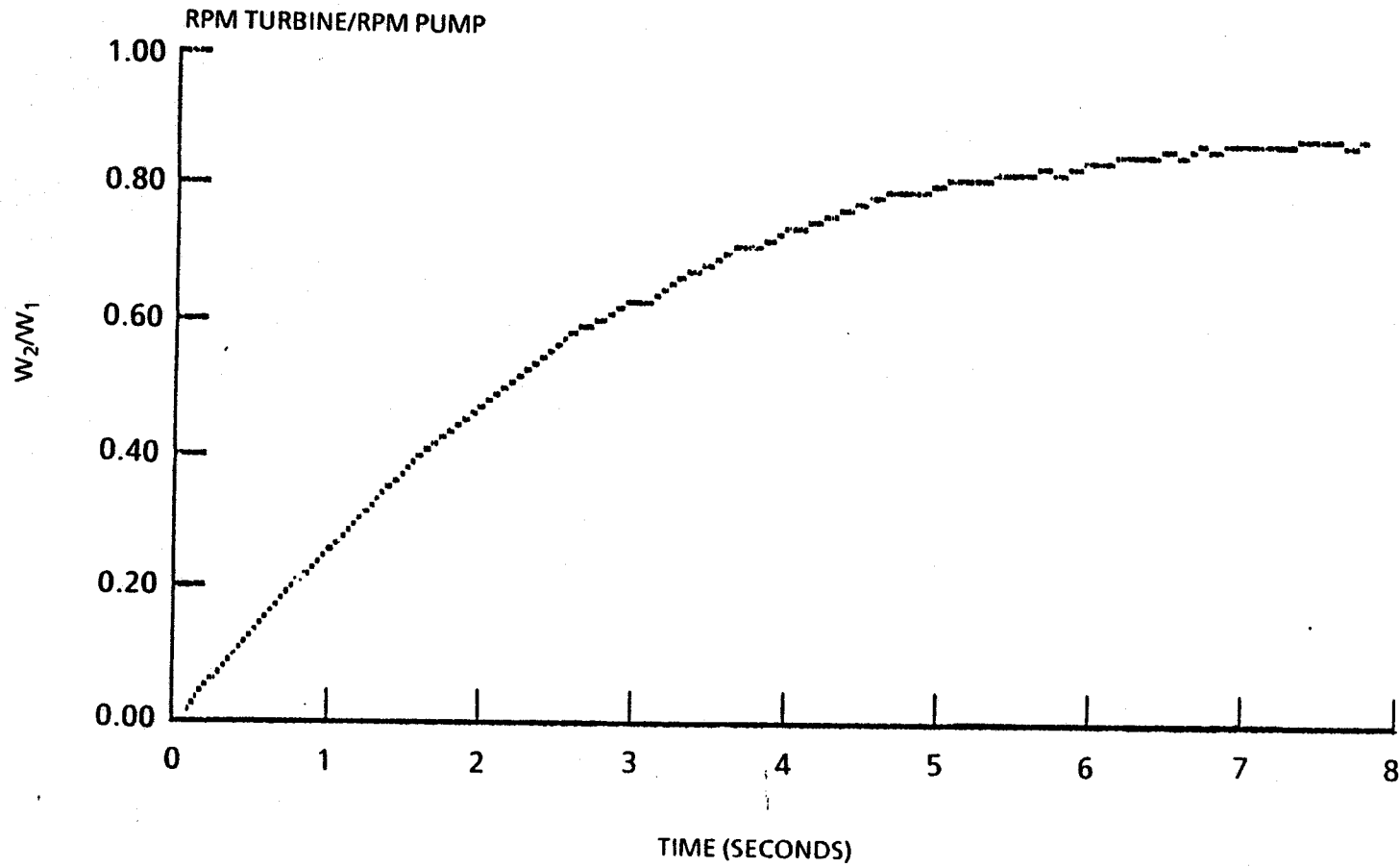
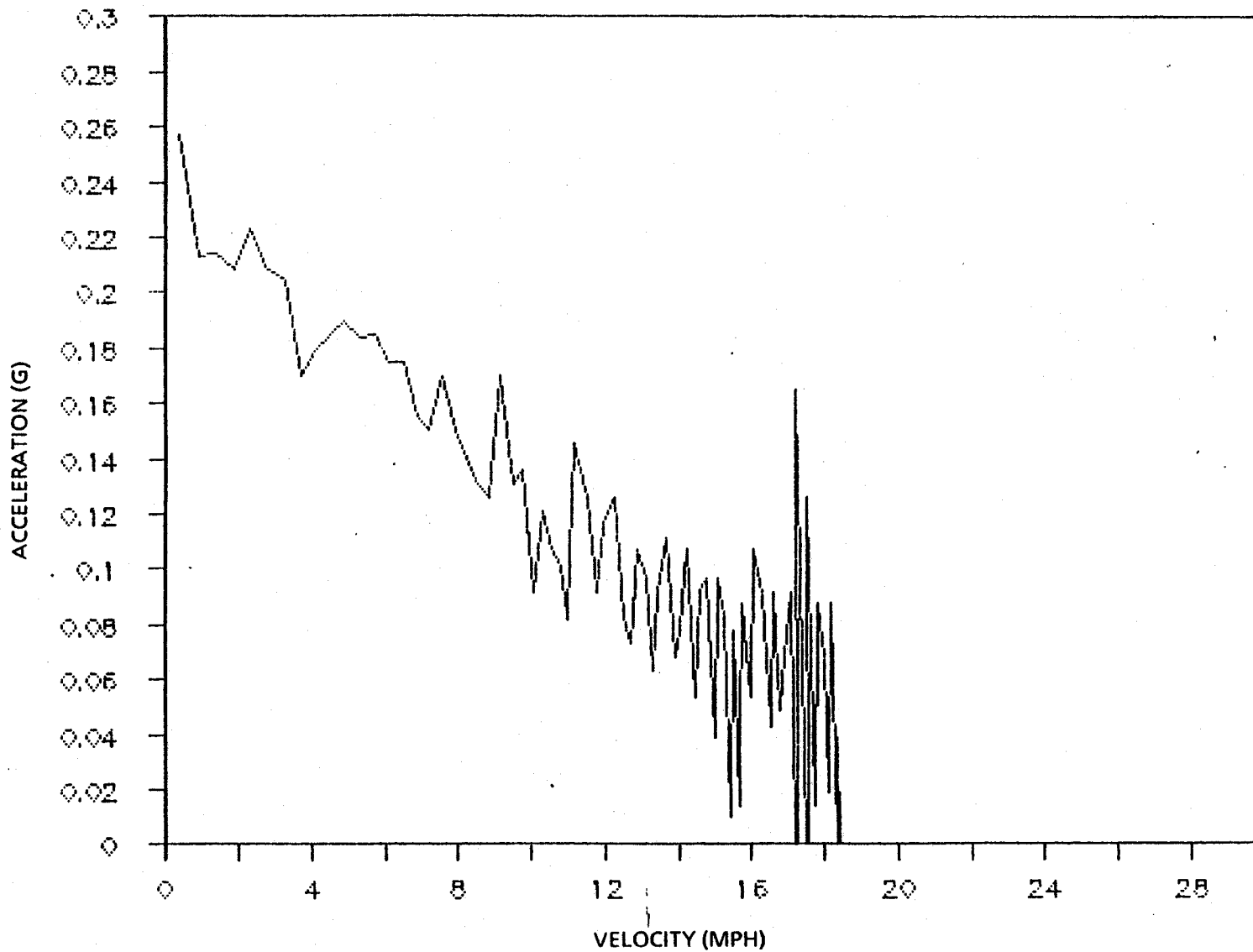

FIGURE B-7. RATIO OF ANGULAR VELOCITY, AUDI 5000S, REVERSE GEAR

UNFILTERED DATA



B-8

FIGURE B-8. VEHICLE ACCELERATION VERSUS VELOCITY, 1986 AUDI 5000S, REVERSE GEAR, IDLE-STABILIZER VALVE FULLY OPEN

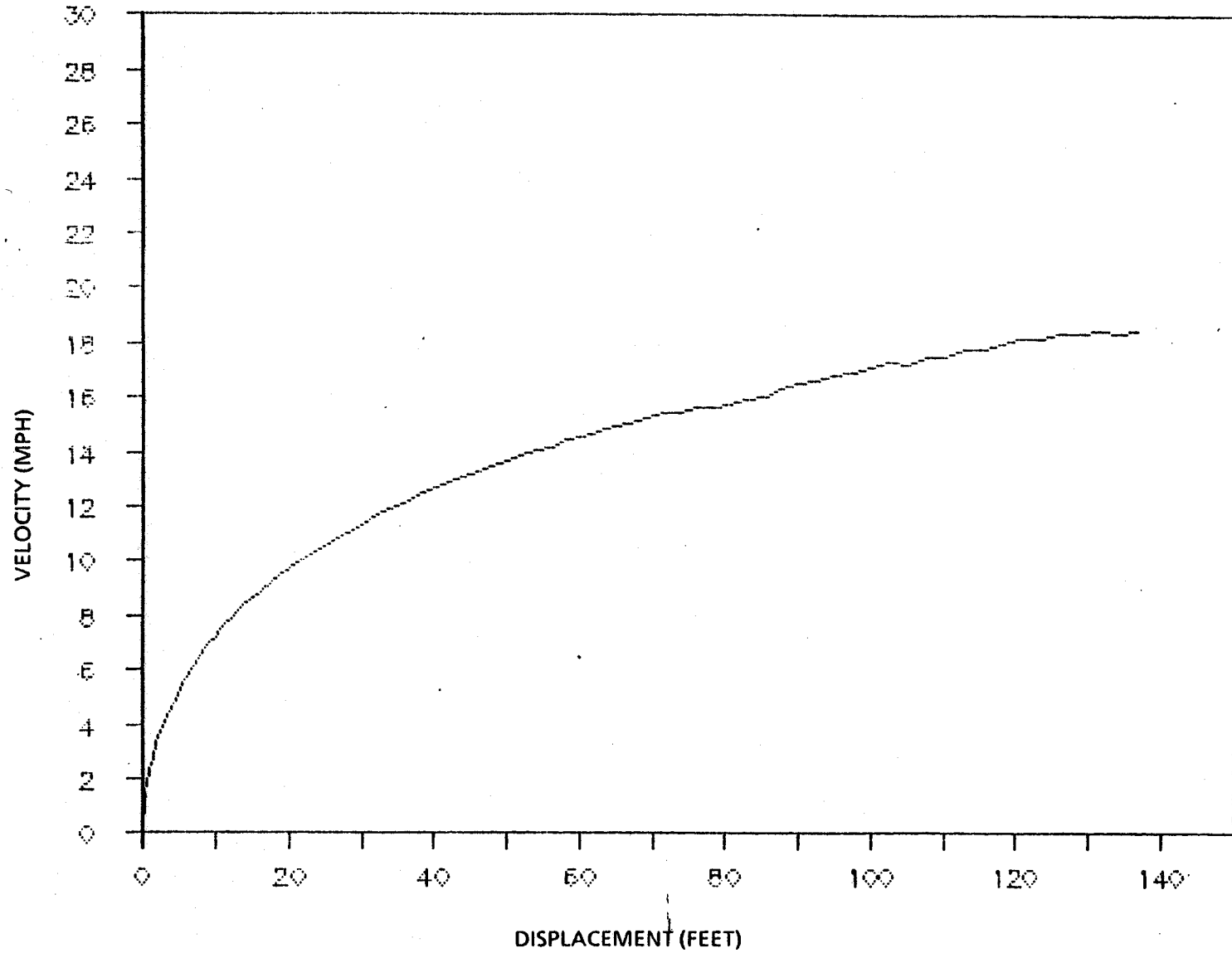

FIGURE B-9. VEHICLE VELOCITY VERSUS DISPLACEMENT, 1986 AUDI 5000S, REVERSE GEAR, IDLE-STABILIZER VALVE FULLY OPEN

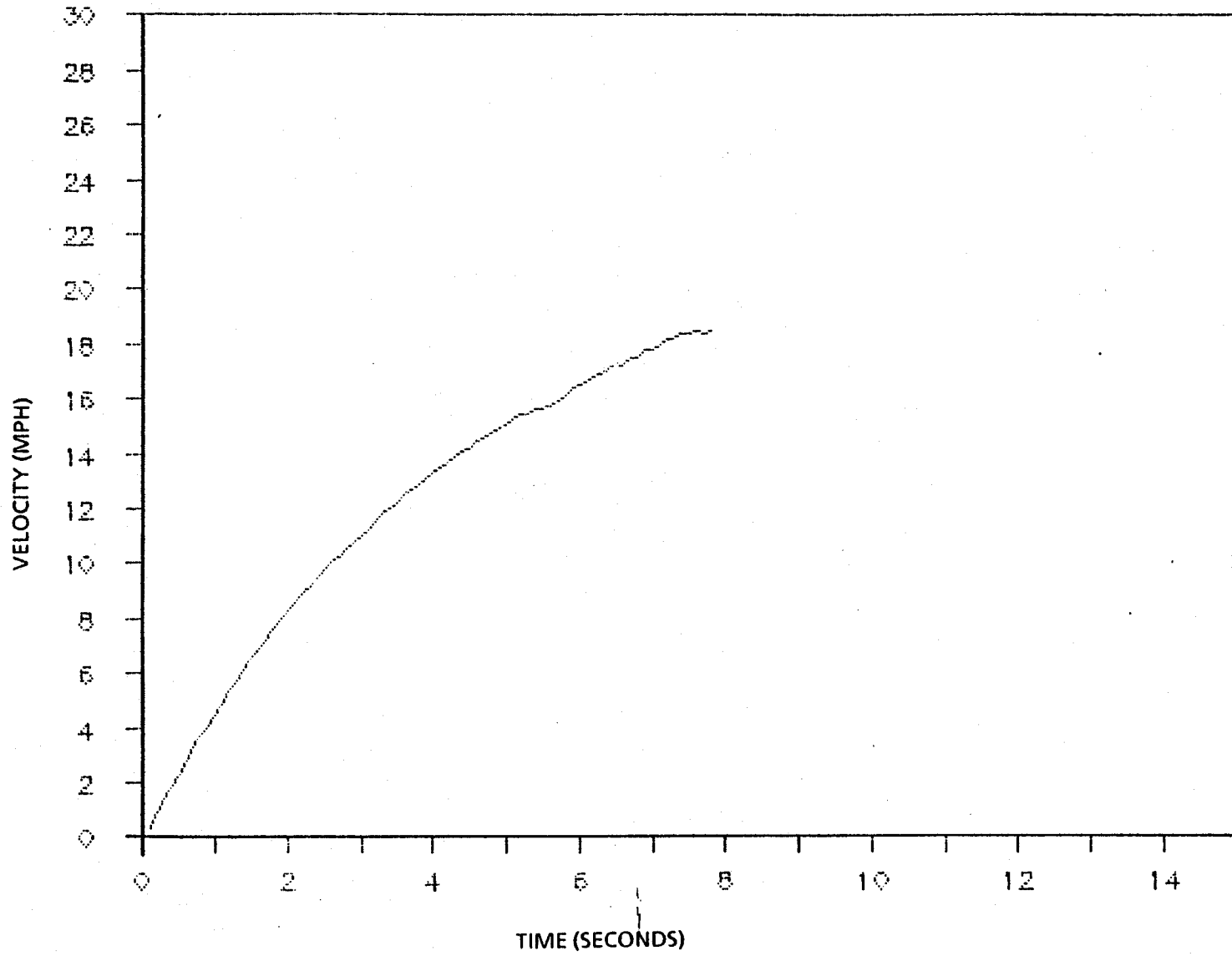

FIGURE B-10. VEHICLE VELOCITY VERSUS TIME, 1986 AUDI 5000S, REVERSE GEAR, IDLE-STABILIZER VALVE FULLY OPEN

UNFILTERED DATA

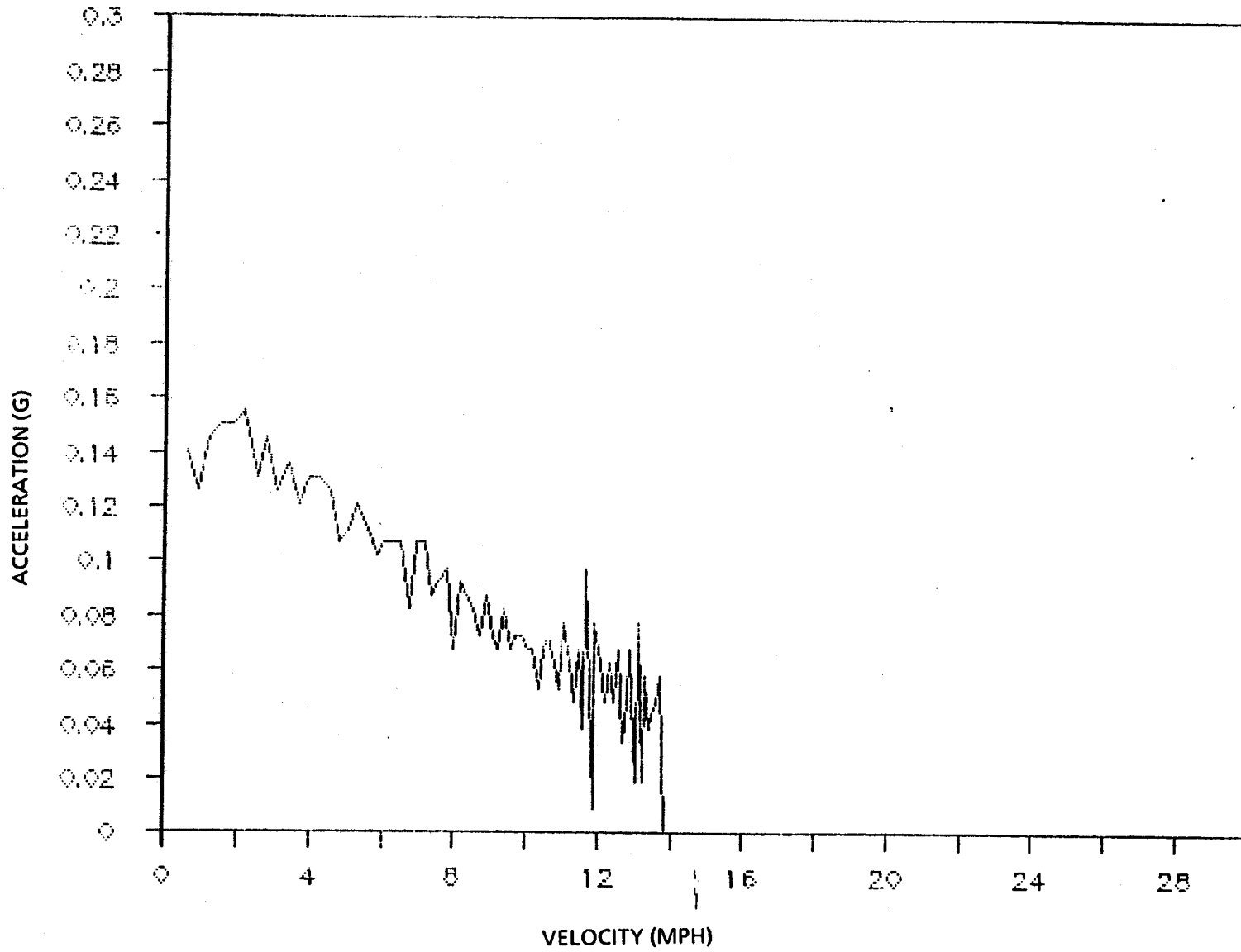

FIGURE B-11. VEHICLE ACCELERATION VERSUS VELOCITY, 1986 AUDI 5000 CS TURBO, REVERSE GEAR, IDLE-STABILIZER VALVE FULLY OPEN

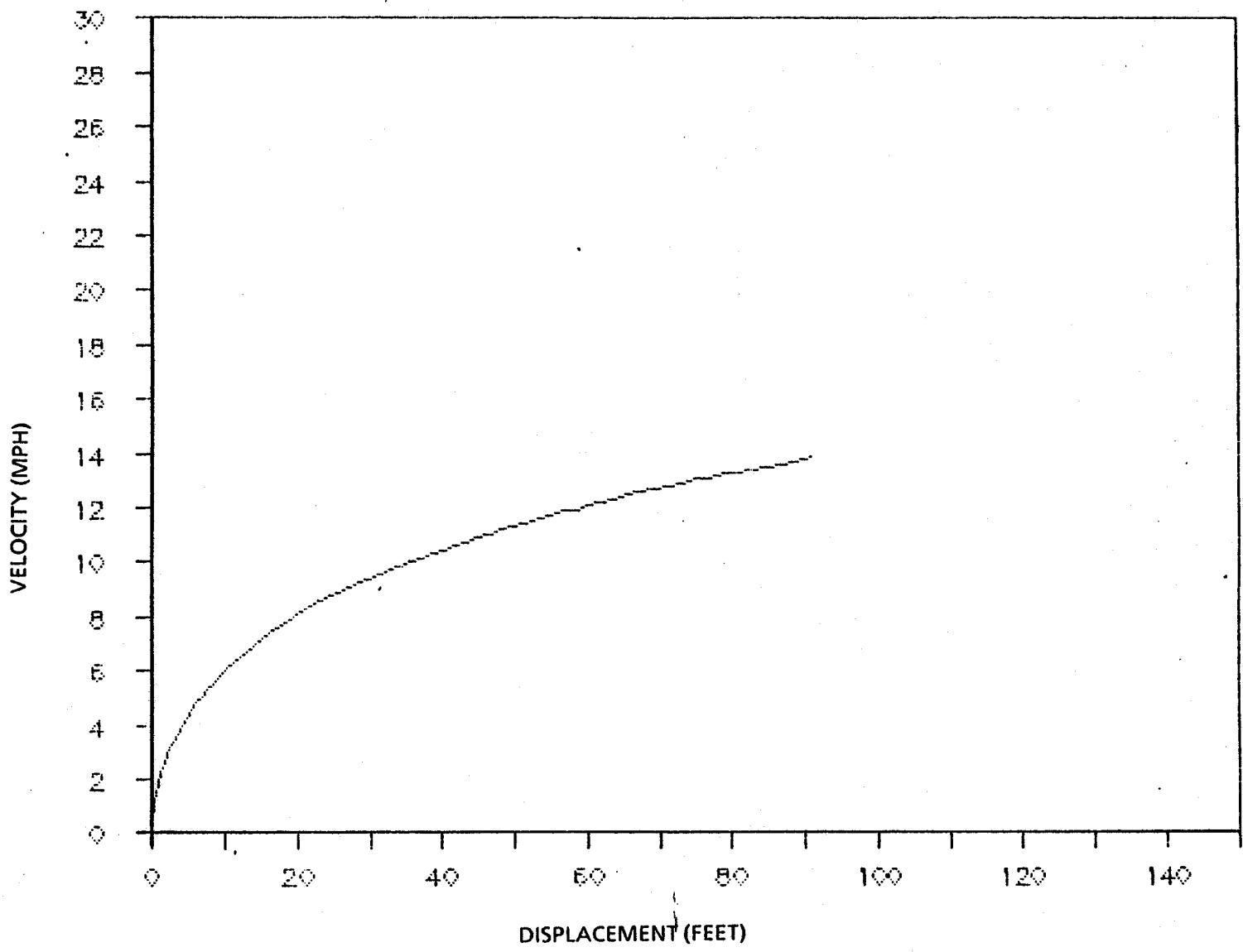

FIGURE B-12. VEHICLE VELOCITY VERSUS DISPLACEMENT, 1986 AUDI 5000 CS TURBO, REVERSE GEAR, IDLE-STABILIZER VALVE FULLY OPEN

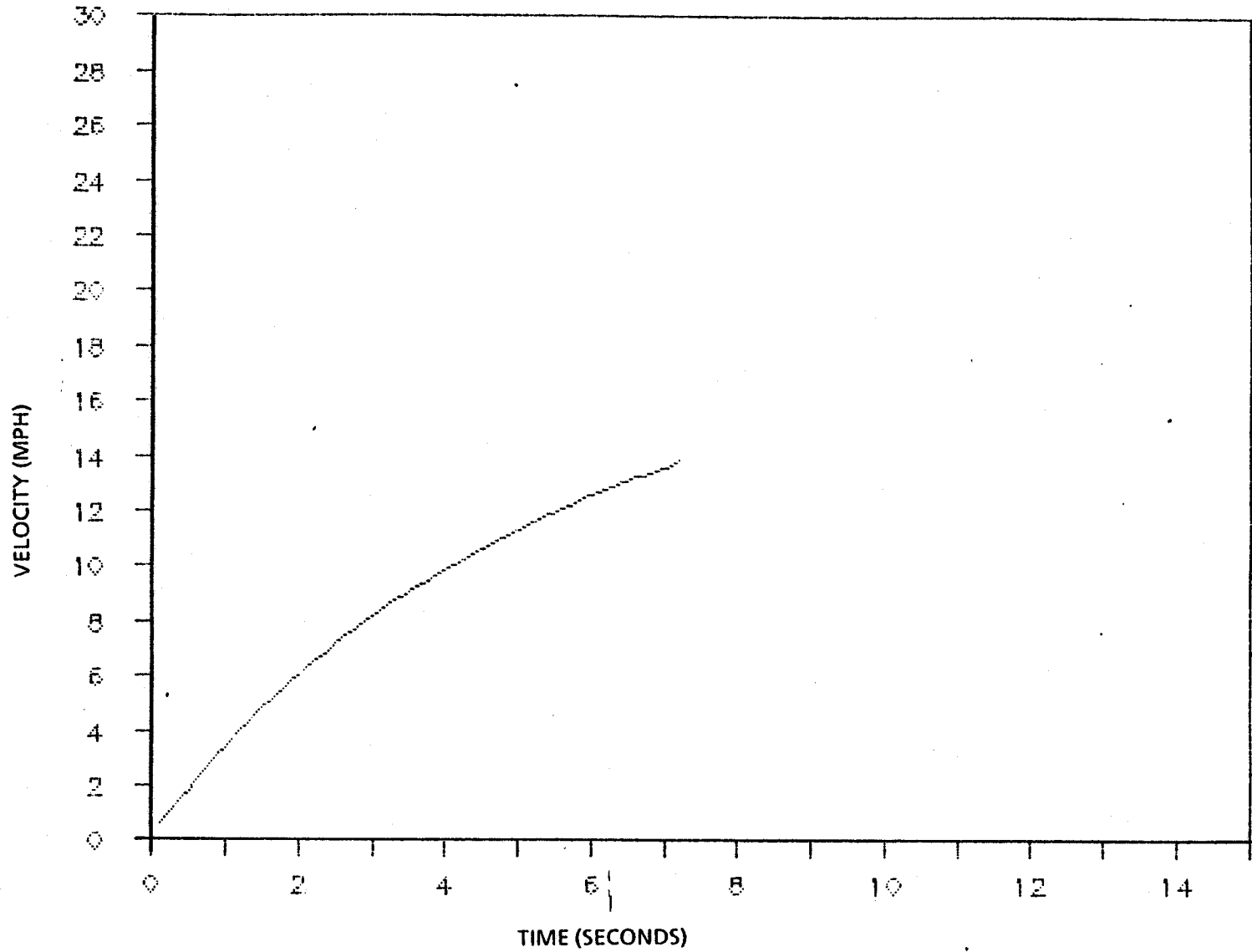

FIGURE B-13. VEHICLE VELOCITY VERSUS TIME, 1986 AUDI 5000 CS TURBO, REVERSE GEAR, IDLE-STABILIZER VALVE FULLY OPEN

UNFILTERED DATA

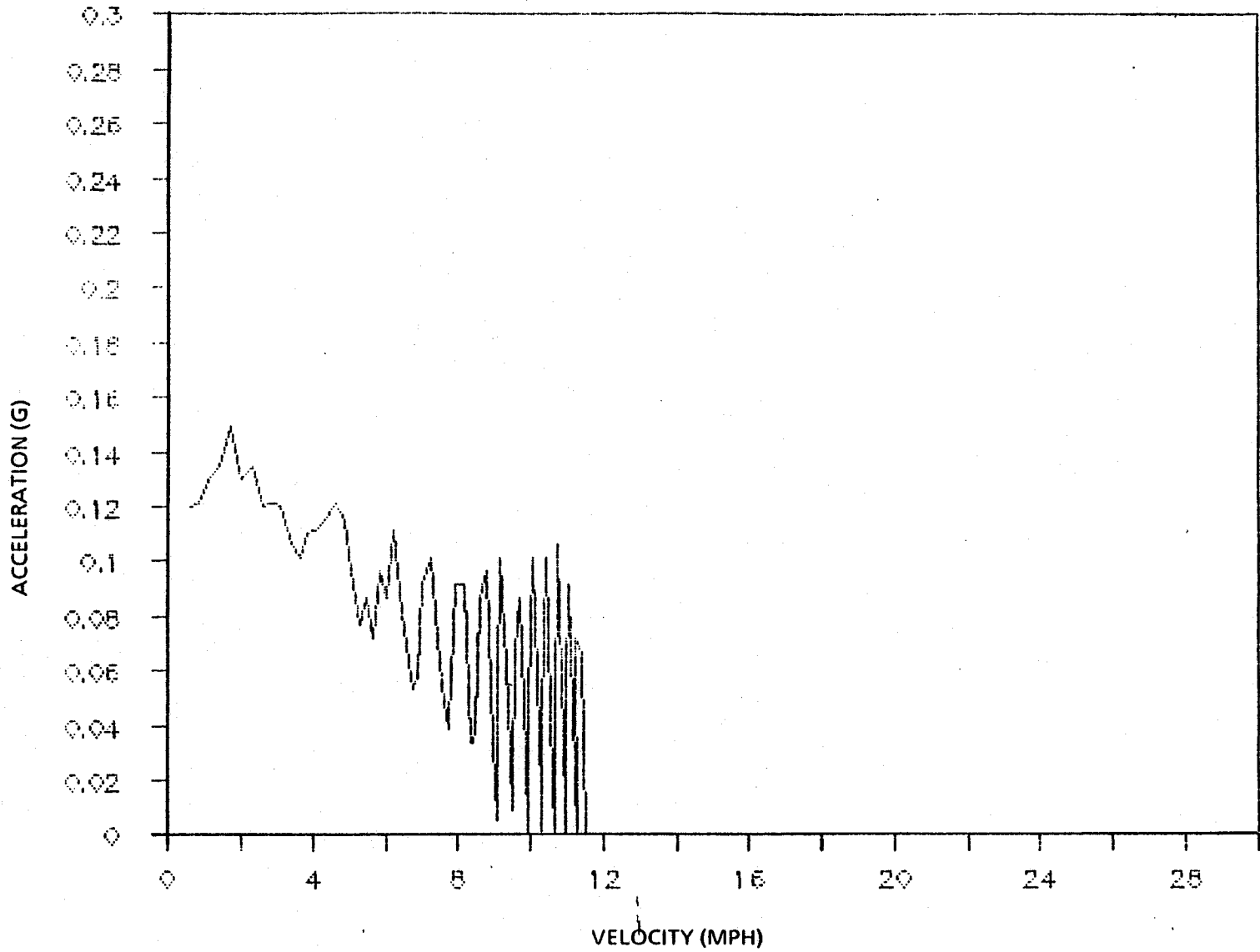

FIGURE B-14. VEHICLE ACCELERATION VERSUS VELOCITY, 1984 AUDI 5000S, REVERSE GEAR, IDLE-STABILIZER VALVE FULLY OPEN

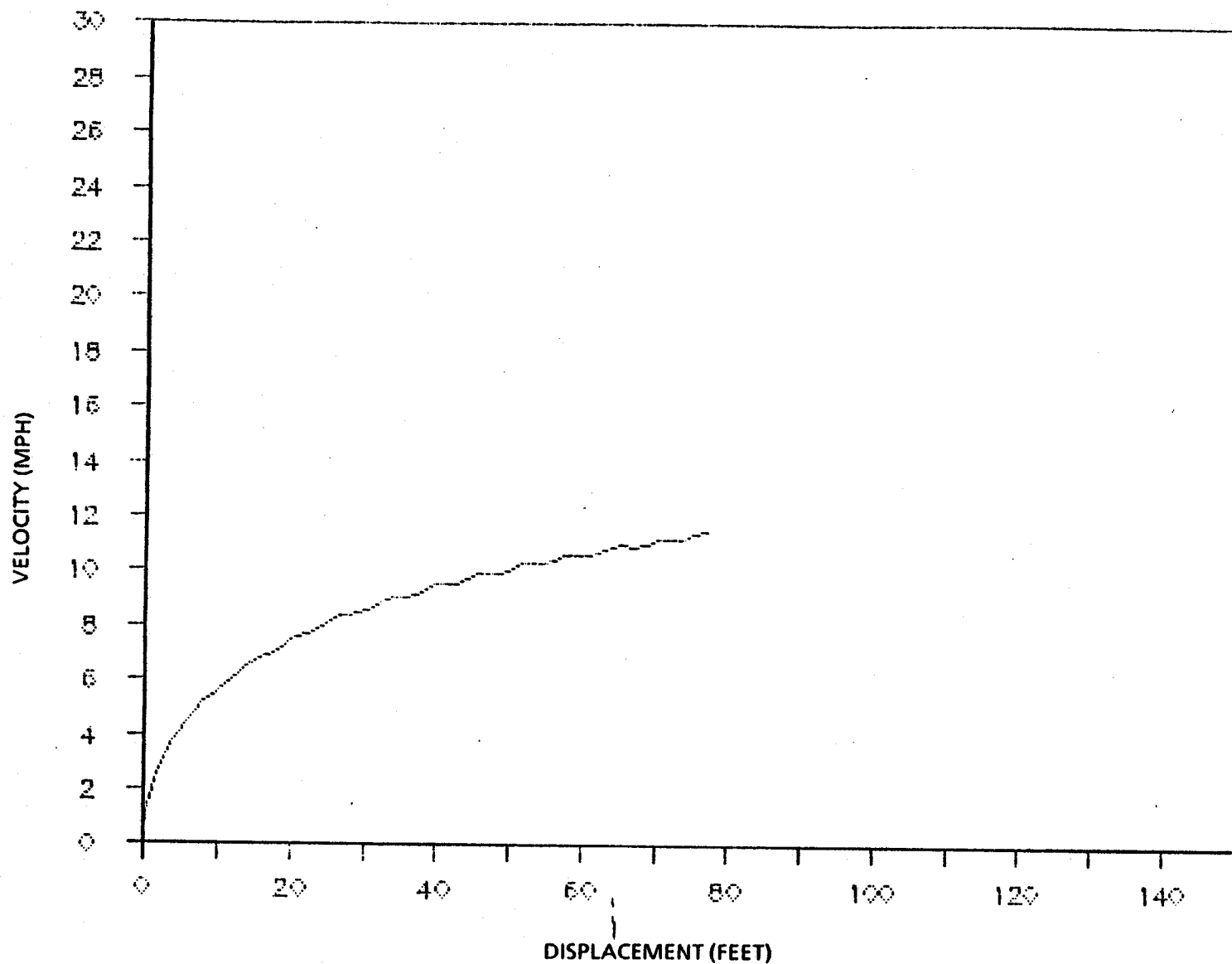

FIGURE B-15. VEHICLE VELOCITY VERSUS DISPLACEMENT, 1984 AUDI 5000S, REVERSE GEAR, IDLE-STABILIZER VALVE FULLY OPEN

B-17/B-18

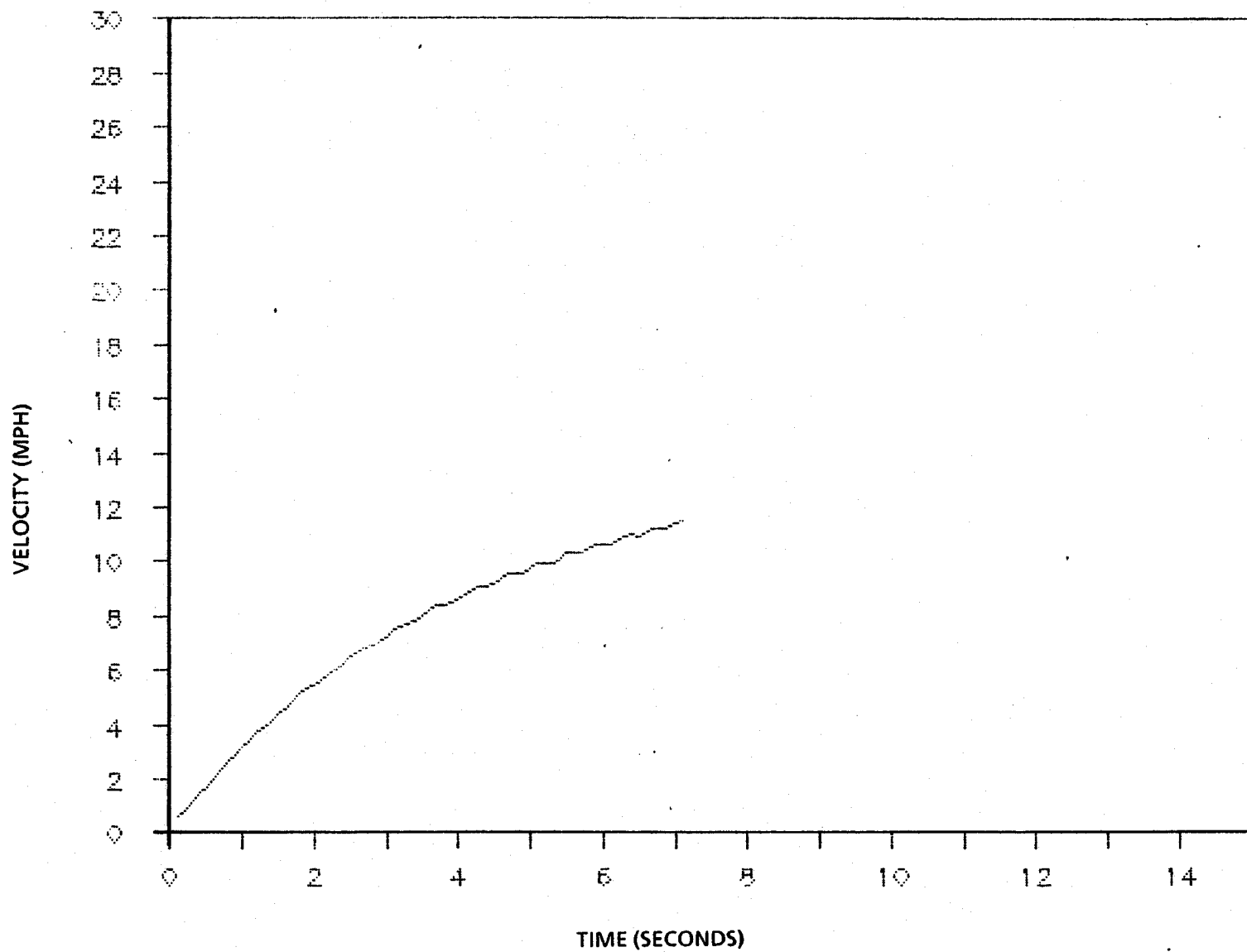

FIGURE B-16. VEHICLE VELOCITY VERSUS TIME, 1984 AUDI 5000S, REVERSE GEAR, IDLE-STABILIZER VALVE FULLY OPEN

APPENDIX C

BRAKE SYSTEM

C.1 INTRODUCTION

After the onset of an SAI, the driver should be able to stop the vehicle by braking. Drivers of Audi 5000s involved in sudden acceleration report that the brake pedal was depressed but the vehicle did not stop. On the assumption that the drivers had properly applied the brakes, the brake system was evaluated to identify any system malfunction which would prevent the driver from stopping the car.

C.2 DESCRIPTION OF THE BOOST SYSTEM COMPONENTS AND THEIR PERFORMANCE

C.2.1. Hydraulic Boost System

The hydraulic boost system, standard on all Audi 5000s built after 1983, is a power-assist mechanism that reduces the force the driver must apply on the brake pedal to stop the car. Located between the brake pedal and the master cylinder, the boost servo is actuated by depressing the brake pedal and deactivated by releasing the brake pedal. With the boost system, the pedal force required to produce .3 g of deceleration (equal to the initial surge caused by a fully open idle stabilizer) is reduced from 90 lb (400 N) to 22.5 lb (100 N), a force reduction of 75 percent (see Figure C-1).

Each time the brake pedal is depressed a high-pressure fluid is delivered to the booster servo. In the event of pumping the brake pedal, a large amount of fluid is required. The hydraulic boost system provides the high-pressure hydraulic fluid as illustrated in Figure C-2.

Hydraulic fluid is pumped by the central pump into a pressure accumulator. A fully charged accumulator stores enough pressurized fluid for about 29 moderate brake applications when the pump is shut off or disabled. The booster servo uses this fluid during braking and then passes it at low pressure to the reservoir. Two pressure-relief valves provide bypass lines directly to the reservoir when pressures exceed allowable levels. When the pump fluid pressure exceeds 155 bars, the pump pressure-relief valve allows fluid to bypass the accumulator and booster servo and return directly to the reservoir. When the accumulator pressure exceeds 150 bars, the accumulator pressure-relief valve allows fluid to bypass the booster servo and return to the reservoir. Fluid in the reservoir is the supply fluid for the pump.

C.2.2 Pump

The continuously operating hydraulic pump is a constant-displacement, eight-piston rotary pump with two independent hydraulic circuits. Six pistons on one circuit supply power steering; two pistons on the second circuit supply fluid for servo braking. The power steering and brake circuits are both supplied with hydraulic fluid from the same fluid reservoir.

The volumetric flow rate from the pump (q) is proportional to engine speed minus losses due to flow past the pump pressure-relief valve or leakages internal to the pump. The flow rate is

$$q = \left(\frac{RPM}{850} \right) q_0 (1 - \alpha P) \quad [C.1]$$

where 850 represents the engine speed at idle, q_0 is the flow rate from the pump at idle, and α is the volumetric efficiency of the pump. The pump is replaced when the flow rate at idle is below 5 cm³/sec.

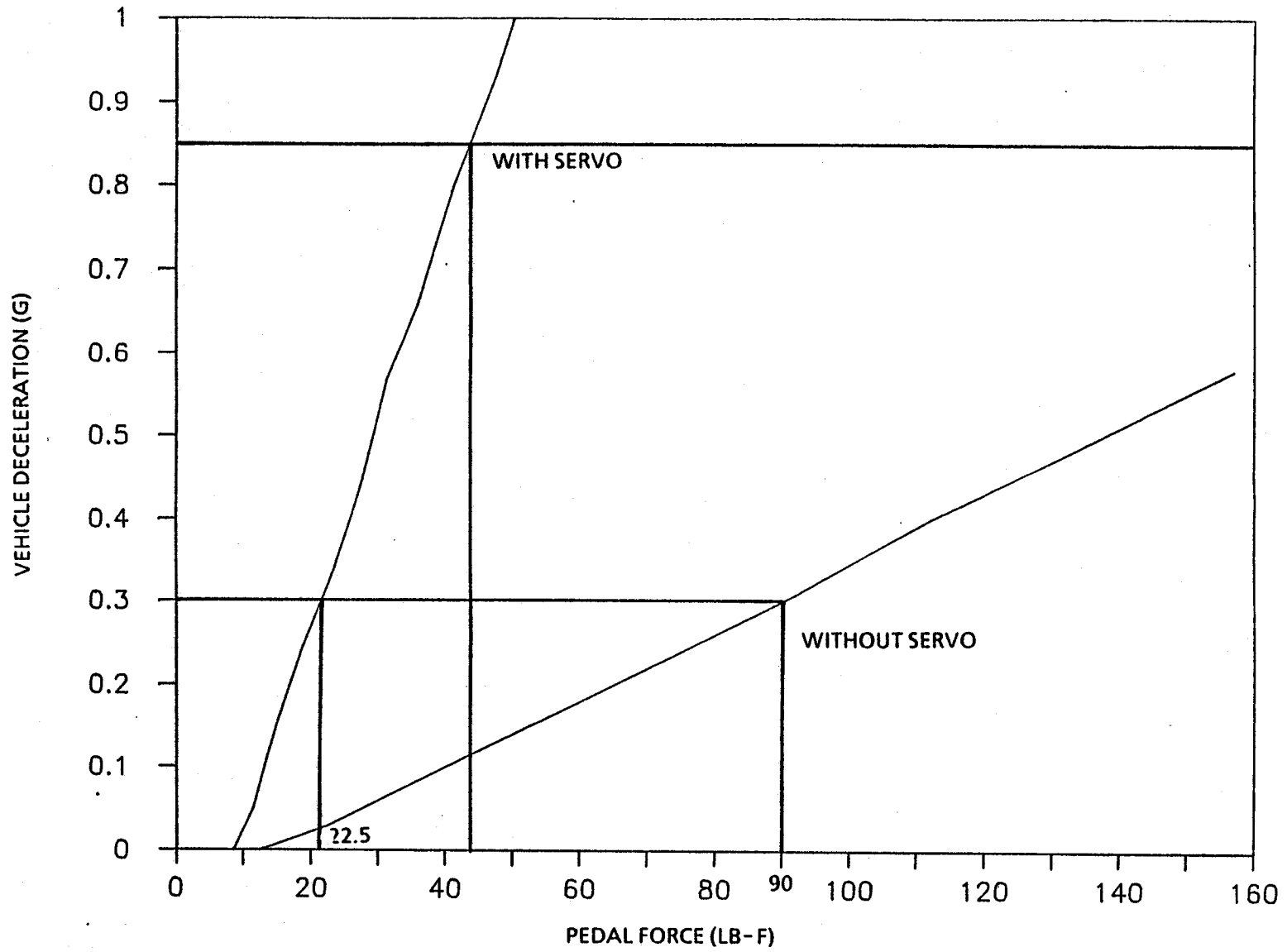

Source: Developed by TSC from VWOA data received through ODI.

FIGURE C-1. BRAKING FORCE REQUIREMENTS

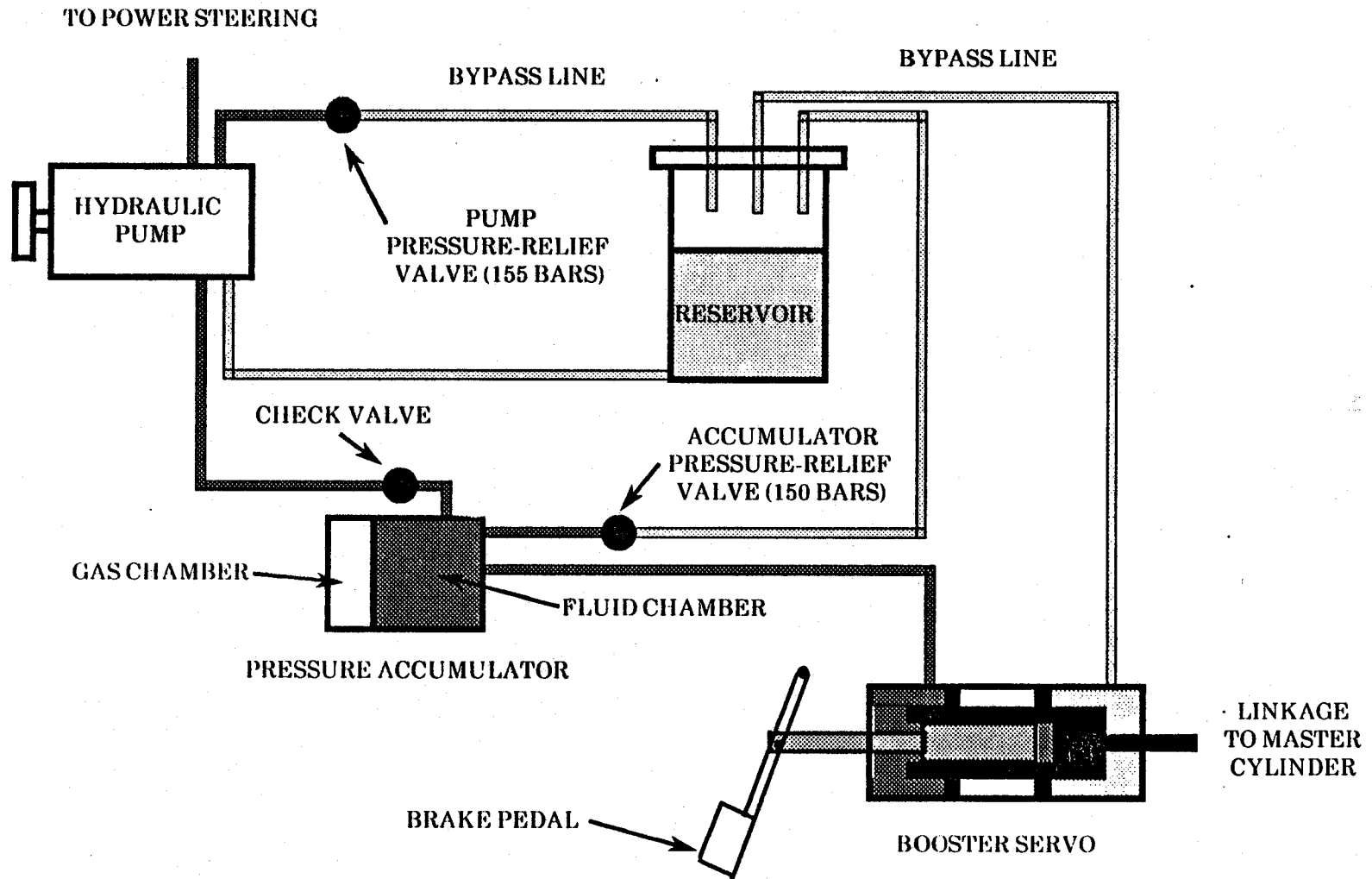

FIGURE C-2. SCHEMATIC OF HYDRAULIC POWER-ASSIST BRAKING SYSTEM

C.2.3 Accumulator

The pressure accumulator is a device that stores hydraulic fluid under pressure to be used by the booster servo. It consists of a rigid shell that encloses a diaphragm which creates two compartments, as illustrated in Figure C-3 (modeled as a moveable piston). One compartment contains a gas at high pressure that is sealed (constant mass). The second compartment is loaded and discharged with hydraulic fluid on an operational basis. Three fluid lines control the loading and discharging of the accumulator. Loading is done through the inlet from the pump; discharging is through the boost servo and pressure-relief valve. Fluid returning back to the pump is prevented by a one-way check valve.

Maximum pressure in the accumulator is limited to the pressure which opens the accumulator pressure-relief valve. The relief valve will open at 150 bars when installed and is replaced when it opens below 140 bars.

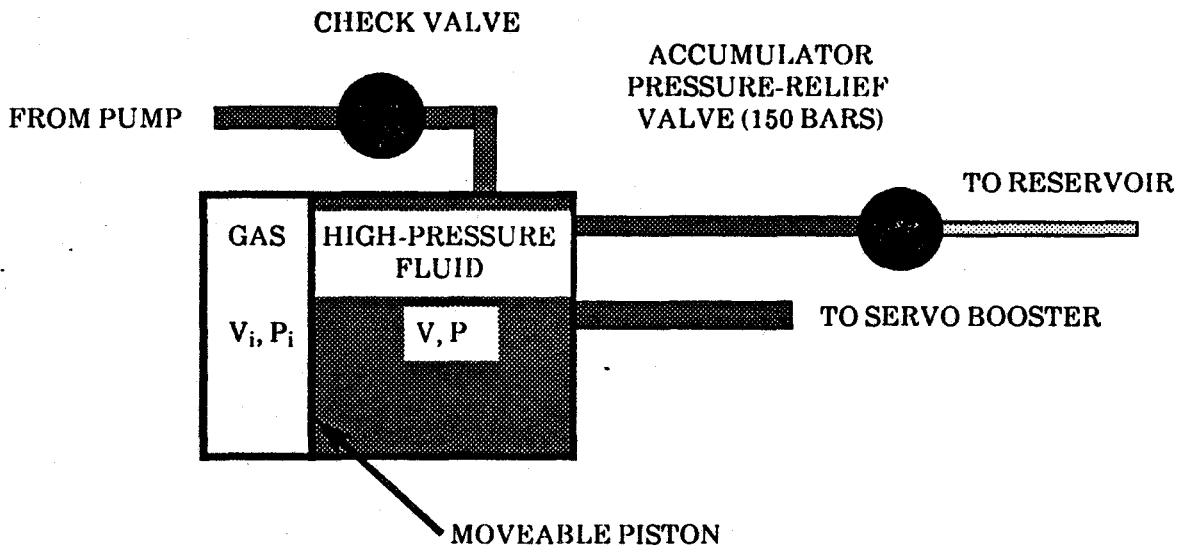

FIGURE C-3. ACCUMULATOR MODEL

Gas pressure varies between the empty pressure (gas pressure when there is no fluid supply in the accumulator) and the full pressure (pressure that opens the relief valve). At installation, the empty gas pressure (P_E) is between 88 and 92 bars. The accumulator is replaced when P_E falls below 30 bars. When the hydraulic fluid pressure is equal to or below the empty pressure, the gas will fill the entire accumulator volume. This volume of gas is the empty volume of the accumulator (V_E). The pump will deliver fluid to the accumulator as long as pressure developed by the pump is greater than the gas pressure in the accumulator. When the gas reaches full pressure (P_F), the relief valve operates continuously until pressure drops below P_F , allowing the hydraulic fluid delivered by the pump to drain into the reservoir.

Gas pressure increases as the fluid volume increases because the trapped gas is being compressed. The diaphragm moves in response to changes in fluid pressure. As fluid pressure increases, the diaphragm compresses the volume of the gas compartment. As the fluid pressure decreases, the

volume of the gas expands. The operating gas pressure (above P_E and less the P_F) depends upon the amount of hydraulic fluid in the accumulator, i.e., the difference between the amount of hydraulic fluid being delivered by the pump and the amount of that fluid required by the boost servo during braking. Assuming the gas behaves like an ideal gas, the expression for the expansion or compression of the gas is

$$P_i V_i^n = P_E V_E^n = P_F V_F^n = \text{CONSTANT} \quad [\text{C.2}]$$

The exponent represents the thermodynamic process undergone by the ideal gas (air). When ($n=1$) the process is isothermal and when ($n=1.4$) the process is adiabatic.

The fluid pressure and gas pressure are considered equal in the accumulator. This equation is valid as long as the fluid pressure is greater than the empty gas pressure. The volume of the hydraulic fluid at any pressure in the accumulator is dependent upon the initial pressure and volume of the gas. For example,

$$V_F = \left(\frac{P_E}{P_F} \right)^n V_E \quad [\text{C.3}]$$

Accumulator Discharge - Loss of fluid in the accumulator is proportional to the number of pedal depressions (N) and the volume of fluid displaced per pedal depression (Δ). The volume of gas in the accumulator during discharging can be expressed as

$$V_i = (V_F + N\Delta) \quad [\text{C.4}]$$

The amount of fluid removed from the accumulator per pedal depression is equal to the volume of fluid entering the assist chamber in the servo unit and is proportional to the pedal displacement. For example, a pedal displacement of 33 mm removes 4.5 cm³ of fluid from the accumulator and produces 20 bars of brake pressure.

Combining equations C.1 and C.2, the pressure during bleed-down (P_B) in the accumulator is

$$P_B = \frac{P_F}{\left(1 + \frac{N\Delta}{V_F} \right)^n} \quad [\text{C.5}]$$

Test data provided by VWOA show the relationship between gas pressure versus the number of 20-bar brake applications. For the test performed, the initial gas pressure was 140 bars; the brake was applied 36 times before the accumulator was emptied. The volume of the accumulator at 140 bars (V_F) is

$$\frac{V_F}{\Delta} = \frac{N}{\frac{P_F}{P} - 1} \quad [\text{C.6}]$$

assuming $n=1$, and substituting values of N and P into equation C.6. V_F/Δ is then substituted into equation C.3 and the bleed-down curve is developed and compared to the test data. When $N=29$, $P=78$; $V_F/\Delta = 36.5$ ($V_F = 164.2$ cm³), the best approximation of the bleed-down curve is achieved. (See Figure C-4.)

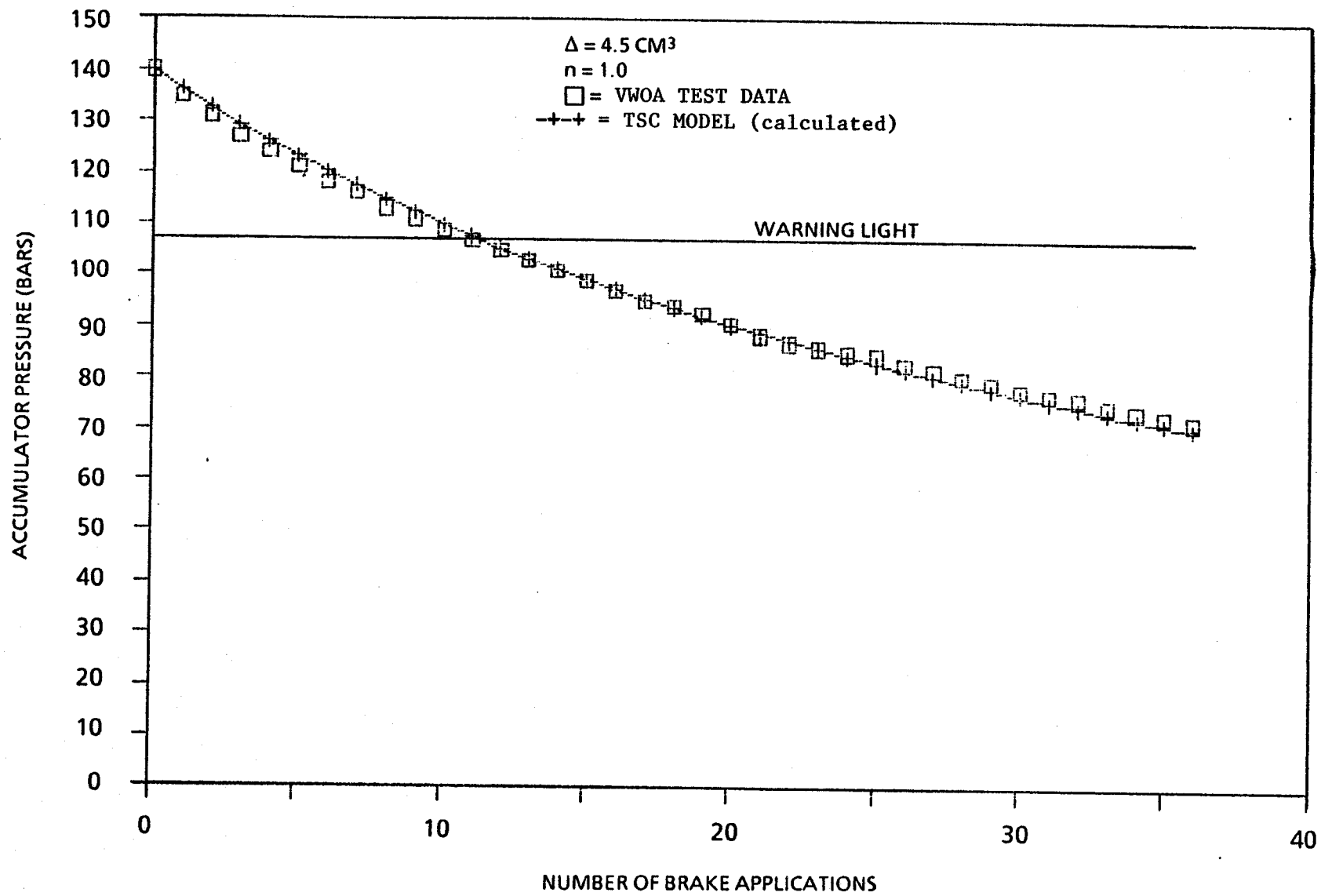

FIGURE C-4. BLEED-DOWN CURVE

For the curve shown $n = 1$, indicating the bleed-down process can be considered an isothermal expansion of an ideal gas, and the assumption to determine the volume of gas in the accumulator is justified. The parameter $\Delta = 4.5 \text{ cm}^3$, the volume of fluid associated with producing a brake line pressure of 20 bars if the empty accumulator pressure is 72 bars. The volume of the gas in an empty accumulator was then determined from equation C.2. Given the initial pressure (140 bars), which is the initial volume (164.4 cm^3) and the empty pressure (72 bars), for $n = 1$ the empty volume of the accumulator is 320 cm^3 .

Loading of the Accumulator – Loading time of the accumulator is defined as the amount of time required to raise the pressure of the gas in the accumulator from the empty pressure to any specified pressure (see Figure C-5). The empty pressure is the gas pressure when there is no hydraulic fluid present in the accumulator. This pressure can range between 92 and 30 bars.

The loading time of the accumulator at idle speed is proportional to the volumetric flow rate of fluid (q) past the check valve from the pump. The volume of gas at any time during loading is

$$V_i = (V_E - qt) \quad [C.7]$$

Combining equation C.7 and equation C.2, the pressure during loading (P_L) in the accumulator is

$$P_L = \frac{P_E}{\left(1 - \frac{qt}{V_E}\right)^n} \quad [C.8]$$

Test data supplied by VWOA show the relationship between gas pressure versus time during loading of the accumulator from empty pressures of 30 and 80 bars. In this instance, it took 19 seconds to load the accumulator from 80 to 144 bars, and 36 seconds to load it from 30 to 144 bars.

If the parameters in equation C.8 are constant, the ratio of the 80-to30-bar loading curve would then also be constant; the test data indicate, however, that this is not the case. The volumetric efficiency of the pump was assumed as $(1 - \alpha P)$ to account for internal pump leakage losses due to pressure.

The flow rate into the accumulator at idle speed is

$$q = q_0 (1 - \alpha P) \quad [C.9]$$

The parameters n , q_0 , and α were varied to achieve the best approximation of the loading curve data (see Figure C-5). For the two curves shown: $n = 1.4$, $q_0 = 8.5 \text{ cm}^3/\text{sec}$, and $\alpha = 0.0023 \text{ bar}^{-1}$.

The volumetric flow rate from the pump (q) is proportional to engine speed minus losses due to flow past the pump pressure-relief valve or leakages internal to the pump. The general expression for the flow rate to the accumulator becomes:

$$q = \left(\frac{\text{RPM}}{850}\right) q_0 (1 - \alpha P) \quad [C.10]$$

where 850 is the idle speed of the engine and $(1 - \alpha P)$ is the volumetric efficiency term.

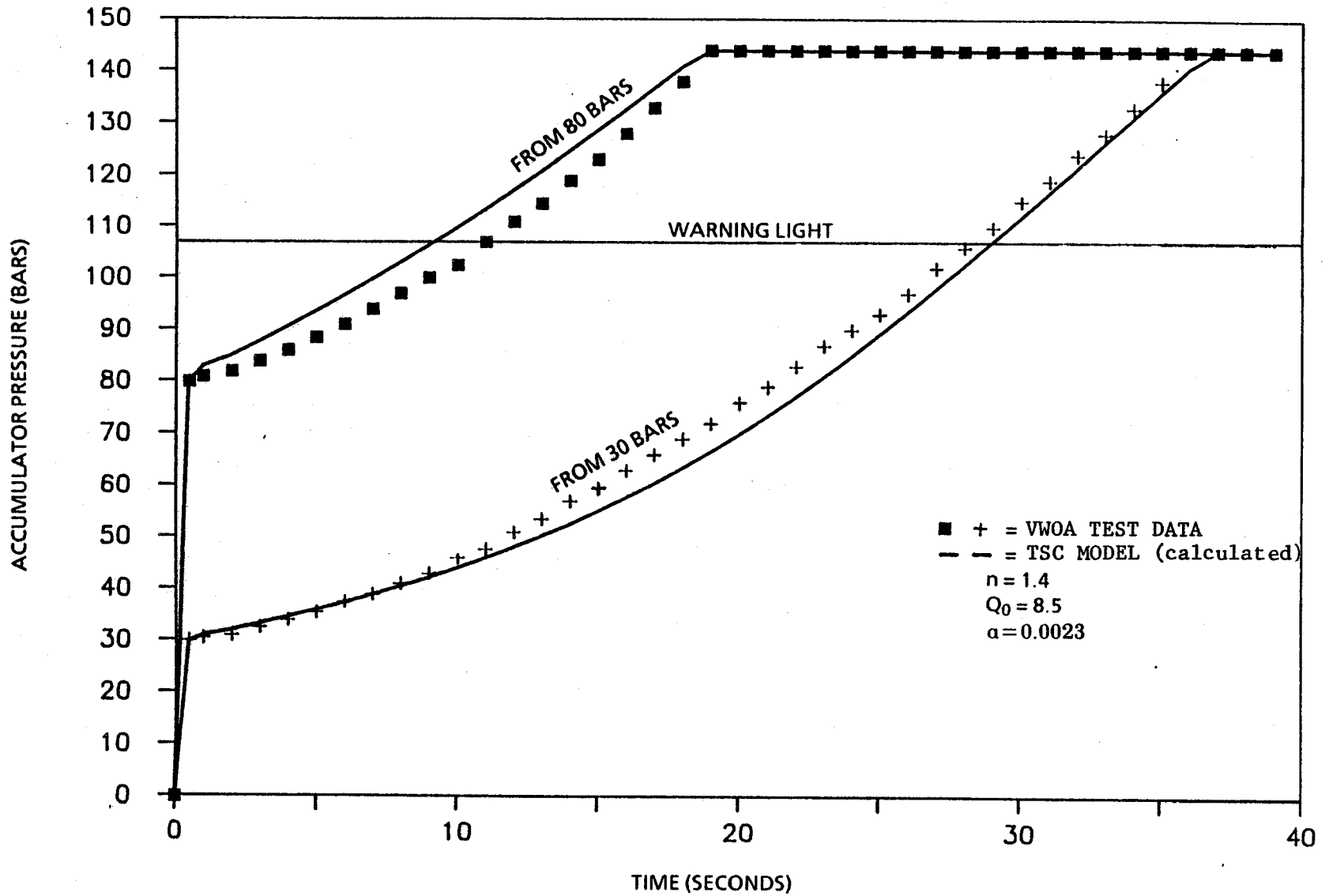

FIGURE C-5. LOADING TIME FOR BRAKE ACCUMULATOR

C.3 THE HYDRAULIC BRAKE ASSIST

Using the high-pressure fluid provided by the accumulator and pump, the boost servo reduces the pedal force required of the driver to brake the car. The hydraulic boost servo is located between the brake pedal and the master cylinder. The three primary components of the boost servo are the boost piston, the spool valve, and the housing. Figure C-6 is a schematic of the boost servo components in their relative locations in the relaxed position. The boost piston is connected to the master cylinder piston so that both pistons have the same relative displacements. The brake pressure developed by the master cylinder is therefore proportional to boost piston displacement.

The power assist is activated when the pedal is depressed by displacing the spool valve. The return spring (located between the piston and the spool valve) deactivates the servo when the pedal is released. The high- and low-pressure ports can be opened or closed depending upon the relative position between the piston and spool valve, but cannot be opened at the same time. The piston and spool valve are cylindrical in shape. Piston seals separate the regions between the piston and the housing into three fluid chambers. These are the power-assist chamber, the fluid supply chamber, and the fluid return chamber. The power-assist chamber is between the housing on the brake-pedal side where the spool valve passes through and the piston seal on the brake-pedal side of the high-pressure port. The supply chamber is between the two piston seals. The return chamber is between the piston seal on the master cylinder side of the high-pressure port and the housing on the master cylinder side where the piston shaft passes through, as shown in Figure C-6. Selected dimensions of the boost piston and spool valve are given in Figure C-7.

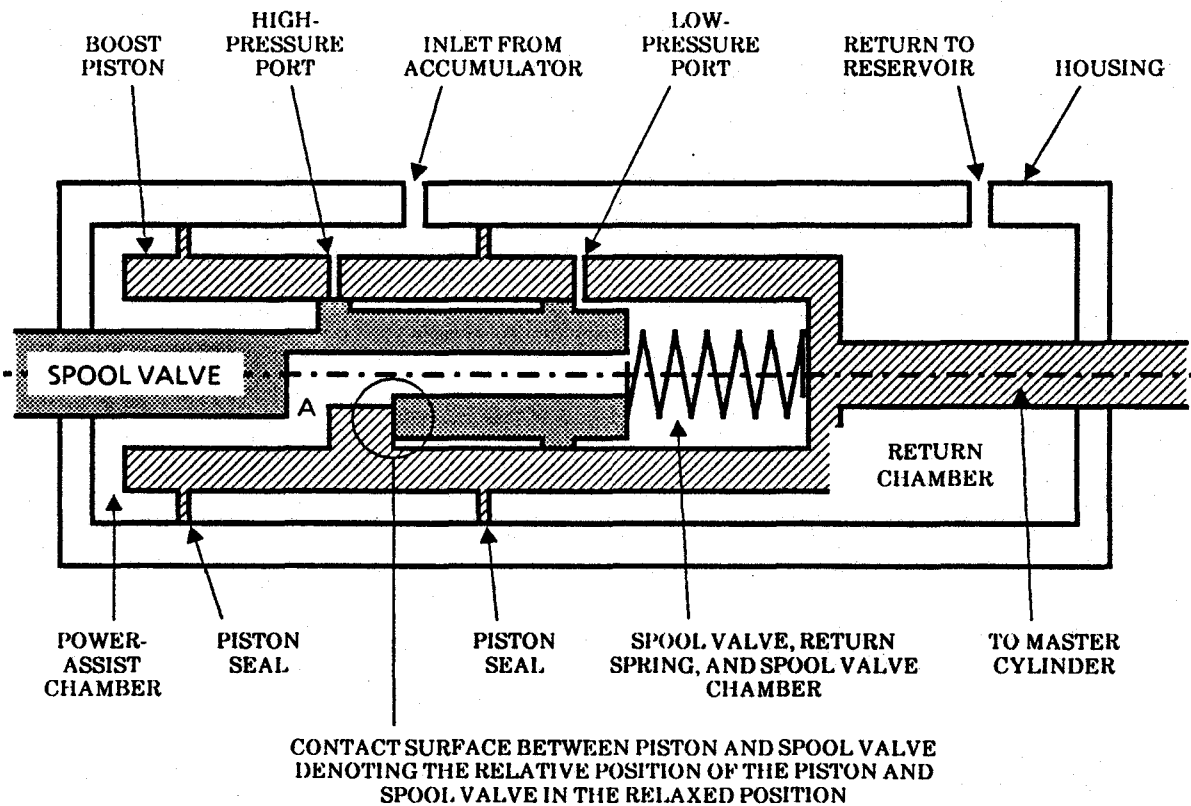

FIGURE C-6. HYDRAULIC BRAKE-ASSIST SERVO IN RELAXED POSITION

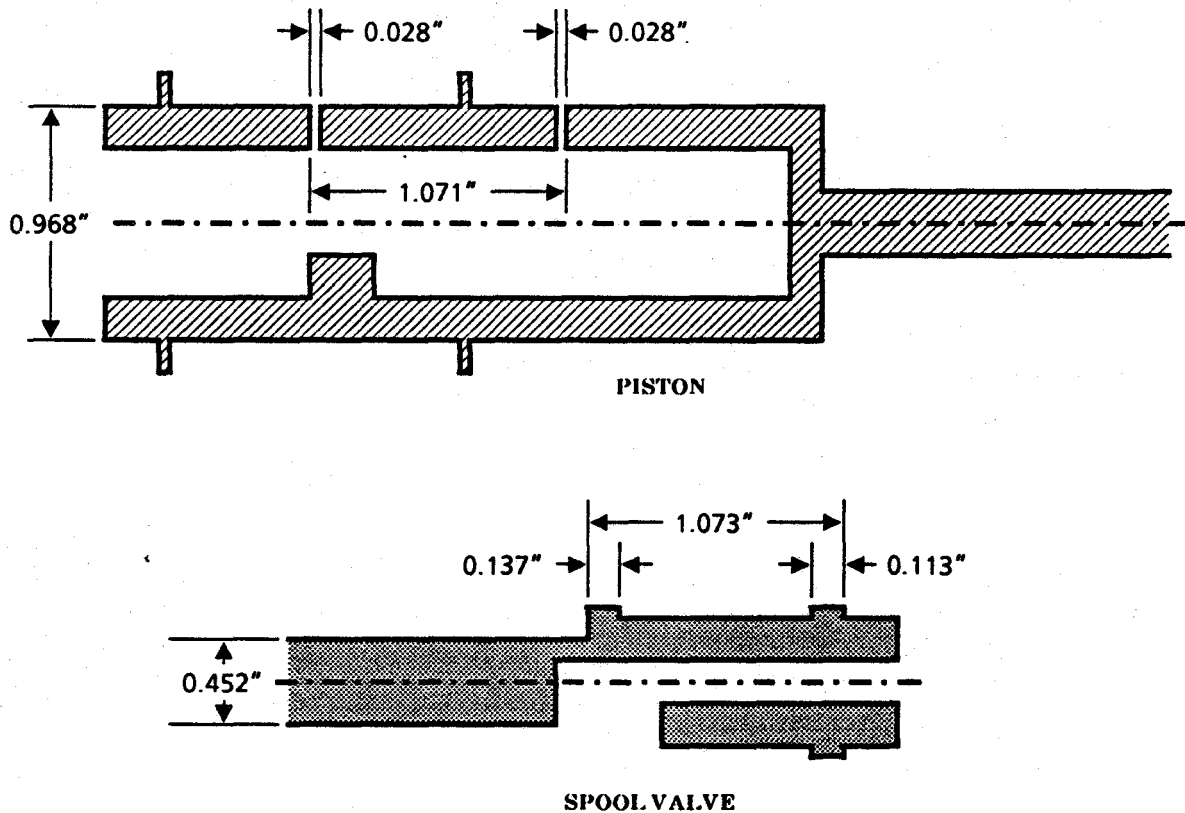

FIGURE C-7. SELECTED DIMENSIONS OF THE PISTON AND SPOOL VALVE

C.3.1 Boost Servo Operation

Before braking, the components of the servo sit in the relaxed position shown in Figure C-6. In this position, the high-pressure port is closed and the low-pressure port is open. The power-assist chamber, the spool valve chamber, and the return chamber are open to each other, through passageway A and the low-pressure port. The three chambers are open to the reservoir through the return line so the pressure in the chambers is equal to atmospheric pressure. Because no pedal force is being applied, the servo is not activated and there is no vehicle braking. The master cylinder piston is displaced as far toward the brake pedal as possible, causing no brake line pressure.

C.4 NORMAL OPERATION

C.4.1 Applying the Brakes

As the driver depresses the brake pedal, the spool valve is initially displaced within the piston, with a force F_s . F_s is proportional to the pedal force the driver applies, but is not equal to it because of the linkages between the pedal and the spool valve. As shown in Figure C-8, when the spool valve is initially displaced the high-pressure port is opened and the low-pressure port is closed.

When the low-pressure port closes, the power-assist chamber and spool valve chamber are sealed from the return chamber. High-pressure fluid from the accumulator flows into the power-assist and spool valve chambers. Since no fluid can pass the closed low-pressure port, the volume of fluid that passes

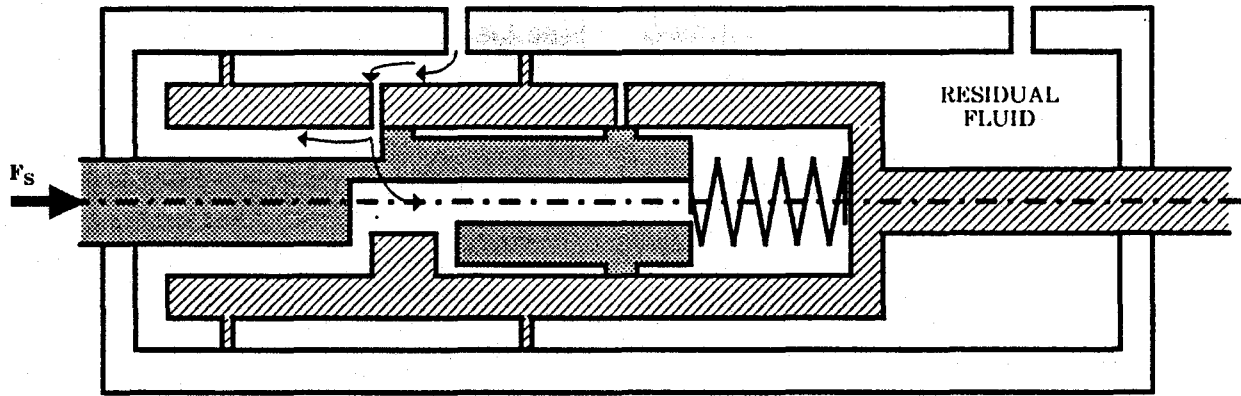

FIGURE C-8. SPOOL VALVE DISPLACEMENT

the high-pressure port is equal to the volume increase of the spool valve and power-assist chambers. Assuming a great enough fluid pressure, the high-pressure fluid forces the boost piston toward the master cylinder, which displaces the master cylinder piston and causes brake line pressure to increase. The spool valve displaces toward the master cylinder at a slower rate than the boost piston. Relative to the boost piston, the spool valve is displaced toward the relaxed position, as shown in Figure C-9. Note that as the boost piston displaces toward the master cylinder, residual fluid in the return chamber is forced back to the reservoir.

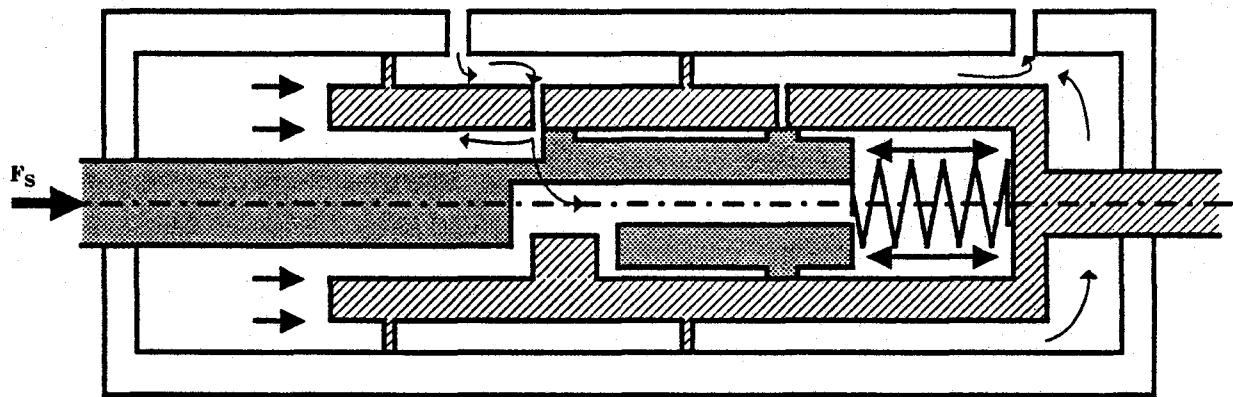

FIGURE C-9. SPOOL VALVE DURING BRAKE RELEASE

Increasing fluid pressure in the assist and spool valve chambers as the piston displaces toward the master cylinder provides the force required to increase the brake line pressure. The fluid pressure acting on the spool valve cross-sectional area provides increasing resistance to the applied pedal force. Because the piston has displaced toward the master cylinder further than the spool valve, the high-pressure port opens slightly. This relative position of the spool valve and piston occurs only when pressure force on the spool valve in the spool valve chamber (F_{sv}) is slightly less than the applied spool valve force (F_s). If the pressure was much less, F_s would have little resistance to displacement within the piston and would allow the high-pressure port to remain fully opened. Similarly, if the

pressure force F_{sv} , were much greater, it would overcome F_s , close the high-pressure port, and open the low-pressure port.

The pressure force in the spool valve chamber increases to equal the applied force to the spool valve (pedal force through linkage), stopping pedal displacement. The increased pressure in the assist chamber displaces the boost piston toward the master cylinder, increasing the brake pressure and closing the high-pressure port. When the high-pressure port closes, the flow into the assist and spool valve chambers is stopped; the forces are balanced and the boost piston no longer moves, as shown in Figure C-10. The applied spool valve force is balanced by the pressure force in the spool valve chamber. The low-pressure port remains closed because the piston displacement stops when the high-pressure port closes. The spool valve will not return to the relaxed position until the brake pedal is released; the applied force is reduced below the pressure force in the spool valve chamber. No fluid enters or leaves the assist and spool valve chambers, and neither the boost piston nor the spool valve moves (the system is in force equilibrium). Figure C-11 shows the forces acting on the piston and spool valve in the equilibrium position.

Because the assist and spool valve chambers are connected through passageway A, their fluid pressures (P_f) are equal. In the equilibrium position, the applied force through the spool valve is equal to the spool valve pressure force in the spool valve chamber, excluding the return spring force. The spool valve force is

$$F_s = F_{sv} = P_f A_s \quad [C.11]$$

where A_s is the cross-sectional area of the spool valve normal to the centerline. The spool valve pressure force (F_{sv}) plus the assist chamber pressure force (F_a) is the boost force (F_b) which produces brake pressure in the master cylinder. The boost force is

$$F_b = F_a + F_{sv} = P_f (A_a + A_s) \quad [C.12]$$

where A_a is the cross-sectional area of the assist chamber. The area of the assist chamber on which the fluid works is the cross-sectional area of the piston (A_t) minus the cross-sectional area of the spool valve (A_s). From the dimensions given in Figure C-7, the area of the assist chamber (A_a) is

$$A_a = A_t - A_s = \frac{\pi}{4} (0.968^2 - 0.452^2) = 0.575 \text{ in}^2 \quad [C.13]$$

Since $A_a + A_s$ is the cross-sectional area of the piston, A_t , the boost force is

$$F_b = P_f A_t \quad [C.14]$$

The purpose of the boost is to reduce the applied pedal force required to brake the car. Since brake pressure is proportional to the boost force (F_b) and the spool valve force (F_s) is proportional to the applied pedal force, the boost servo reduces required pedal force only if F_b is greater than F_s . Combining equations C.11 and C.14, the boost force as a function of applied spool valve force is

$$F_b = \frac{A_t}{A_s} F_s \quad [C.15]$$

The servo booster multiplies the input force by the ratio of the spool valve cross-sectional area to the piston cross-sectional area. From the dimensions given in Figure C-7,

$$F_b = \frac{A_t}{A_s} F_s = \left(\frac{0.968}{0.452} \right)^2 F_s = 4.59 F_s \quad [C.16]$$

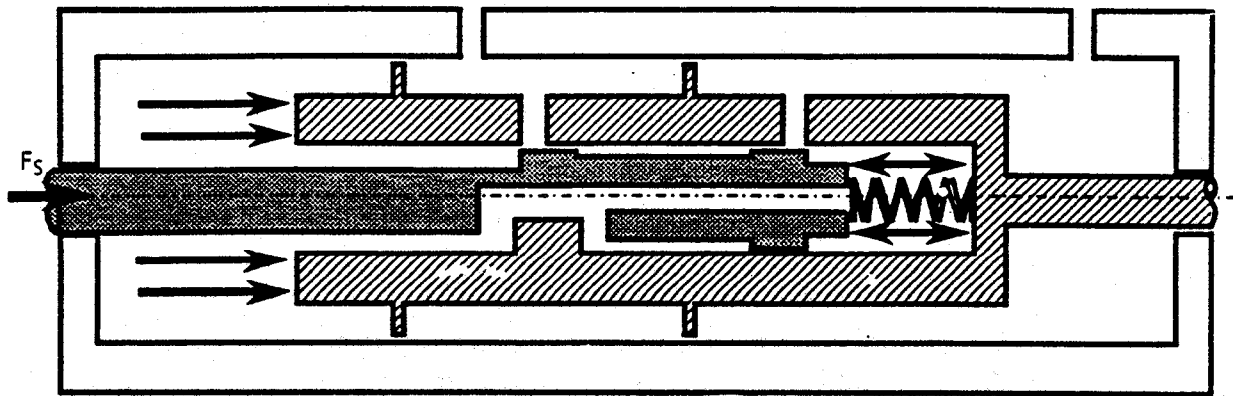

FIGURE C-10. CLOSED HIGH-PRESSURE PORT

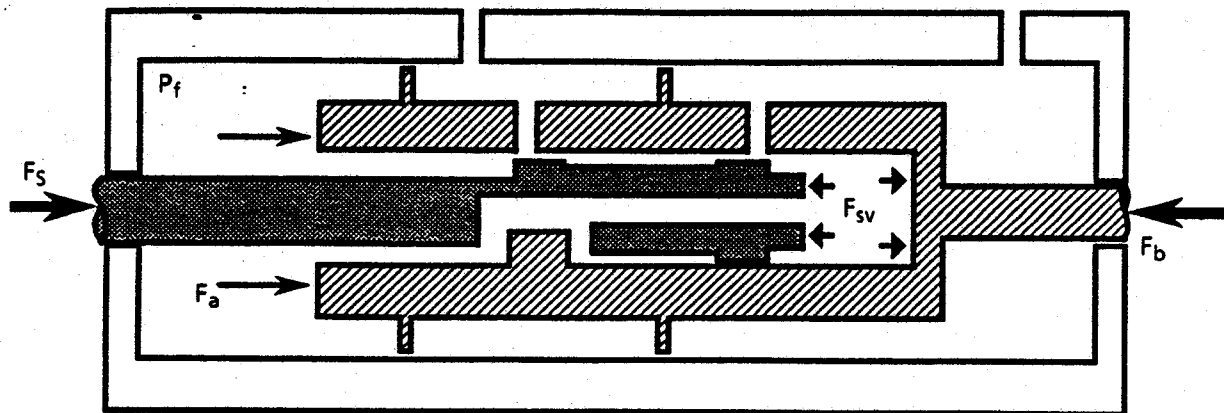
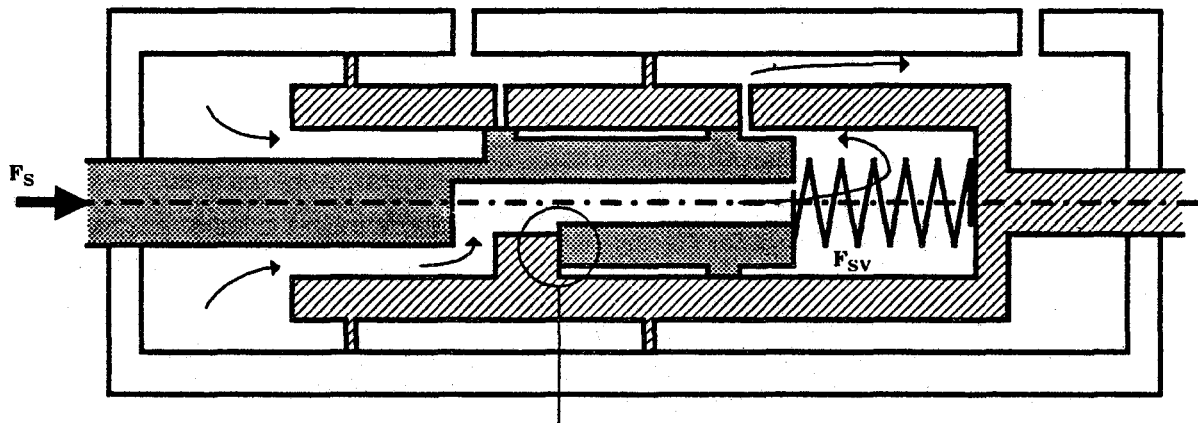

FIGURE C-11. BOOST SERVO COMPONENTS IN EQUILIBRIUM POSITION

The boost force will be 4.59 times the input force for normal operation of the boost servo. The system will remain in equilibrium as long as F_s remains constant. If F_s increases by ΔF_s , the spool valve is displaced toward the master cylinder, which opens the high-pressure port. Fluid then flows into the spool valve and assist chambers, increasing the fluid pressure. As pressure is gained, the force F_{sv} will increase to the applied force $F_s + \Delta F_s$, and stop spool valve displacement. The piston displaces toward the master cylinder, which closes the high-pressure port and increases boost force to $F_b + 4.59\Delta F_s$ at the new equilibrium. Similarly, if the driver decreases F_s by ΔF_s , the spool valve is displaced toward the brake pedal, and opens the low-pressure port. As fluid flows from the spool valve and assist chambers into the return chamber, fluid pressure decreases. As pressure is lost, the pressure force F_{sv} decreases to the applied force $F_s - \Delta F_s$. The piston displaces toward the brake pedal, decreases boost force to $F_b - 4.59\Delta F_s$, and closes the low-pressure port at the new equilibrium.

C.4.2 Releasing the Pedal

When the brake pedal is released, the applied force becomes zero. As shown in Figure C-12, the pressure force in the spool valve chamber (F_{sv}) pushes the spool valve back to the relaxed position relative to the piston, and the return spring holds the spool valve in this relaxed position. The assist and spool valve chambers open to the return chamber through the low-pressure port while the high-pressure port remains closed. Fluid at high pressure in the assist and spool valve chambers flows into the return chamber and lowers the fluid pressure. The brake pressure that was developed displaces the piston back toward the brake pedal and forces more fluid into the return chamber. Eventually, the assembly returns to the relaxed position shown in Figure C-6.



CONTACT SURFACE BETWEEN PISTON AND SPOOL VALVE
DENOTING THE RELATIVE POSITION OF THE PISTON AND
SPOOL VALVE IN THE RELAXED POSITION

FIGURE C-12. SPOOL VALVE, RELAXED POSITION (FOOT OFF PEDAL)

C.5 FAILURE OF THE BOOST SERVO

Failure of the boost servo can occur when the equilibrium fluid pressure is equal to the supply pressure, thus preventing pressure in the servo from increasing. For example, an applied force increase from F_s to $F_s + \Delta F_s$ displaces the spool valve within the piston and opens the high-pressure port. Since no potential exists across the port (because the fluid pressures are equal), no fluid enters the assist and spool valve chambers, the pressure in the servo does not increase, and no additional

fluid boost is created by increasing the applied force. The increase in the applied force (ΔF_s) that displaced the spool valve transmits from the spool valve to the piston by direct contact. The spool valve displaces full stroke within the piston due to ΔF_s because the F_{sv} cannot increase by ΔF_s to stop its displacement. At full stroke the piston and spool valve are in contact at a surface in the spool valve chamber. Since the additional force is transmitted directly to the piston, the additional force developed by the boost servo is equal to the additional force, ΔF_s . The piston displaces toward the master cylinder due to the increase in force, which increases brake pressure. The increase in brake pressure in the failure mode is proportional to F_s , not $4.59\Delta F_s$ as was the case in normal operation. A failure would occur if the fluid pressure force in the spool valve chamber, F_{sv} , was maximum before the applied force increased. When the applied force increases, F_{sv} cannot increase because fluid pressure does not increase. When F_s is greater than F_{sv} , $F_s > P_f A_s$ the boost servo cannot provide fluid boost. At or above the failure level of applied force, an increase in force raises the boost force by an amount equal to the increase in applied force. Since brake pressure increases in proportion to an increase in boost force, the increase is proportional to ΔF_s , whereas the increase in brake pressure during normal operation ($F_s < F_{sv}$) is proportional to $4.59\Delta F_s$.

The boost servo provides boost assist until the fluid pressure in the servo reaches the supply pressure. The boost force is 4.59 times the applied force. The maximum spool valve pressure force, $F_{sv\ max}$, is the spool valve pressure force when the fluid pressure in the servo is equal to the supply pressure. In equilibrium at $F_{sv\ max}$, the servo provides the maximum boost-assisted boost force of $4.59F_{sv\ max}$, the maximum boost-assisted brake pressure. As long as the pressure in the servo remains at the supply pressure, the boost servo will produce at least $4.59F_{sv\ max}$. Any applied force greater than $F_{sv\ max}$ will be produced by an additional boost force of $F_s - F_{sv\ max}$. The total boost force in the failure mode is $4.59F_{sv\ max} + (F_s - F_{sv\ max})$.

The fluid supply pressure can be between atmospheric pressure and 150 bars during normal boost servo operation. Therefore, failure of the boost servo occurs at different applied force levels depending upon the supply pressure. When the supply pressure is atmospheric pressure, there is no boost assist, and the boost-assisted brake pressure is zero. The driver must apply the entire force required to achieve any brake pressure when there is no supply pressure. Based on the data supplied by VWOA, the boost servo will provide boost-assisted brake pressure up to 150 bars when the supply pressure is 140 bars. A brake pressure of 150 bar corresponds to 0.85 g of deceleration. Figure C-13 shows the relationship between vehicle deceleration and pedal force for supply pressures of 140, 120, 100, 80, 60, and 30 bars and without servo (atmospheric pressure). This figure also illustrates the change in behavior of the braking system due to a servo-assist failure. Before the failure, vehicle deceleration increases rapidly as a function of pedal force. At the failure pressure, the curve is discontinuous; the servo cannot supply additional fluid boost. Increasing the pedal force from the failure pressure, the brake pressure increases at a rate approximately 6 times less than the prefailure rate.

C.5.1 Behavior of the Brake Pressure With and Without the Servo Booster

The shaft from the boost piston in the servo assist is connected to the piston in the master cylinder. Therefore, the brake pressure is directly proportional to the boost force (see Figure C-14). Test data supplied by VWOA (see Appendix B) show that the brake pressure is linearly proportional to pedal force with or without servo assist. Brake pressure can be developed with or without the servo booster. The servo assist allows the driver to achieve 30 bars of brake pressure with 22.5 lb (100 N) of pedal force. Without the assist, 90 lb (400 N) of pedal force is required to achieve the same brake pressure. The upper limit of servo operation corresponding to a pedal force of 72 lb (310 N) and an accumulator pressure of 140 bars is 150 bars of brake pressure. The brake pressure increases from 150 bars at the same rate as the "without servo" curve. The servo assist will multiply the pedal force by 4.59 if the pedal force is less than the pressure force in the spool valve chamber. Once the pedal force becomes greater than the spool valve pressure force, the servo force will increase equally with pedal force. Brake pressure is proportional to the servo force by a constant of proportionality, expressed as $P_b k F_b$.

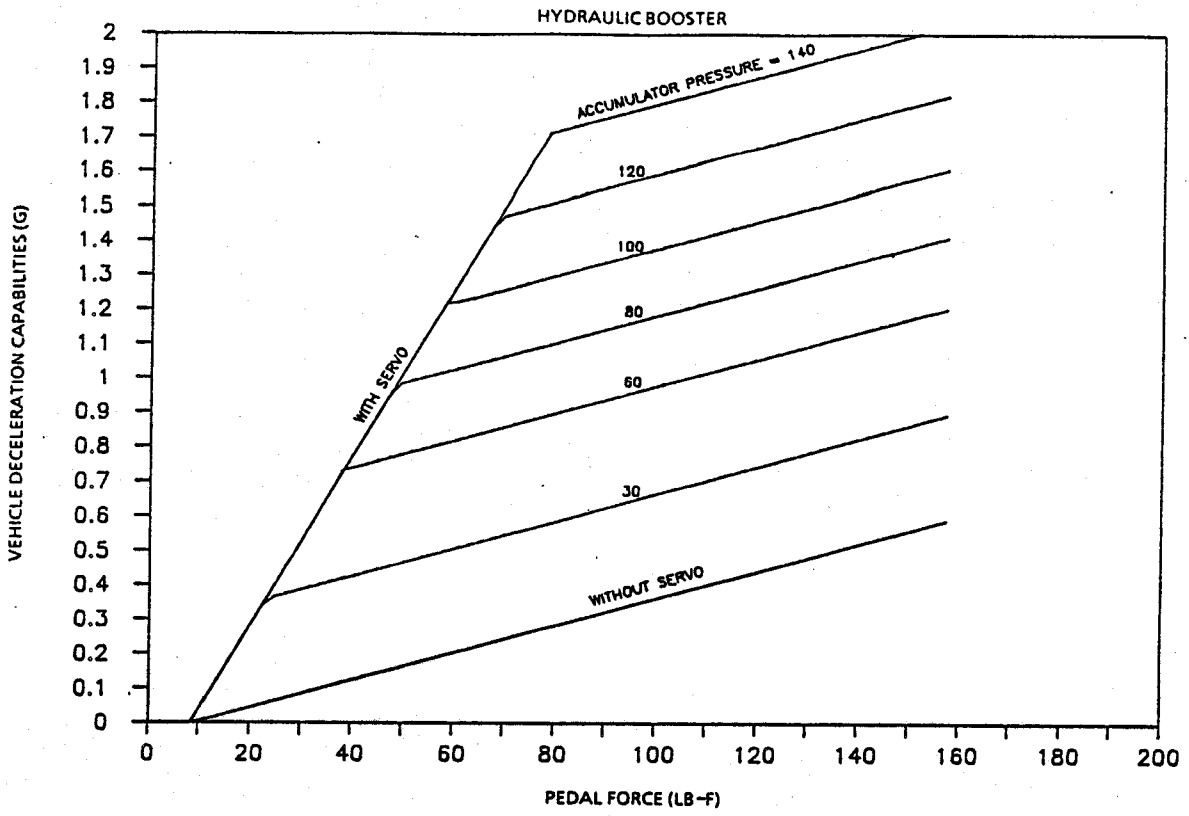

FIGURE C-13. DECELERATION CAPABILITY AS A FUNCTION OF PEDAL FORCE AND ACCUMULATOR PRESSURE

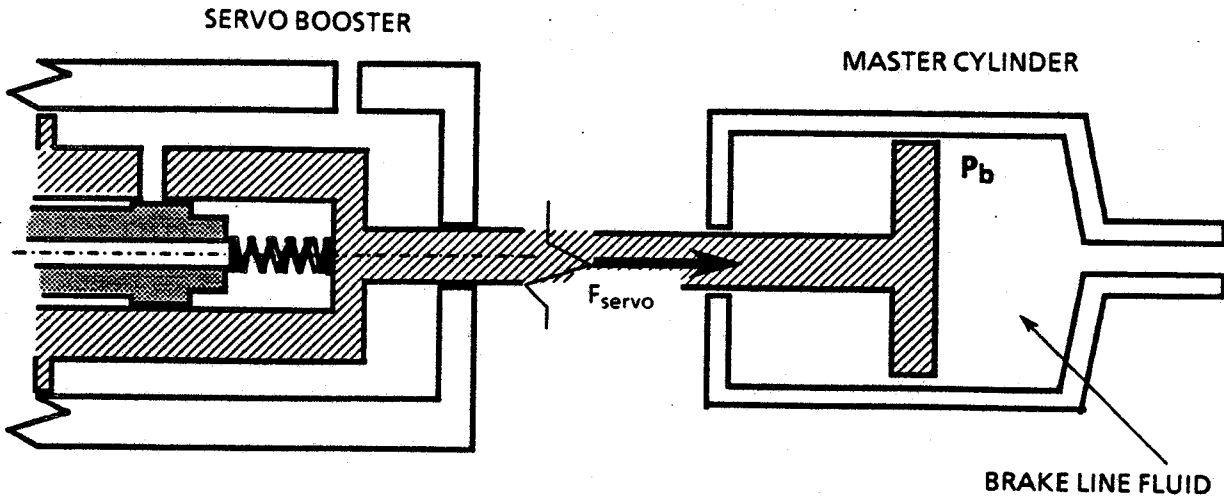

FIGURE C-14. SERVO BOOSTER-MASTER CYLINDER PISTONS

From the previous discussion, the boost force in the equilibrium can be written

$$F_b = F_s + F_a \quad [C.17]$$

where F_s is the applied spool valve force and F_a is the assist chamber pressure force. Substituting Equation C.14 into the above equation, F_s is

$$F_s = \frac{F_a}{\frac{A_t}{A_s} - 1} \quad [C.18]$$

from which the boost force is

$$F_b = F_a \left(1 + \frac{1}{\frac{A_t}{A_s} - 1} \right) = 1.28 F_a \quad [C.19]$$

The relationship between the accumulator pressure and the brake line pressure is

$$P_b = k' P_f \left[1 + \frac{1}{\frac{A_t}{A_s} - 1} \right] = 1.28 k' P_f \quad [C.20]$$

From this relationship and the data supplied by Audi, the value of k' can be determined, from which the maximum brake pressure for any given supply pressure can be calculated. The maximum boost-assisted brake pressure for several supply pressures is given in Table C-1. Pedal force compared to pedal travel is shown in Figure C-15.

TABLE C-1. MAXIMUM BOOST-ASSISTED BRAKE PRESSURE

P_f (supply pressure) Bar	P_b (brake pressure) Bar
140	150
120	129
100	107
80	86
60	64
30	32
0	0

C.6 MECHANICAL EFFECTS TO DRIVER RESPONSE

Total brake failure would be obvious after an incident. In order for the system to completely fail, the hydraulic brake fluid must leak internally to the master cylinder or leak to the environment.

Evidence of a failure would remain in such a closed hydraulic system. A low fluid level in the brake

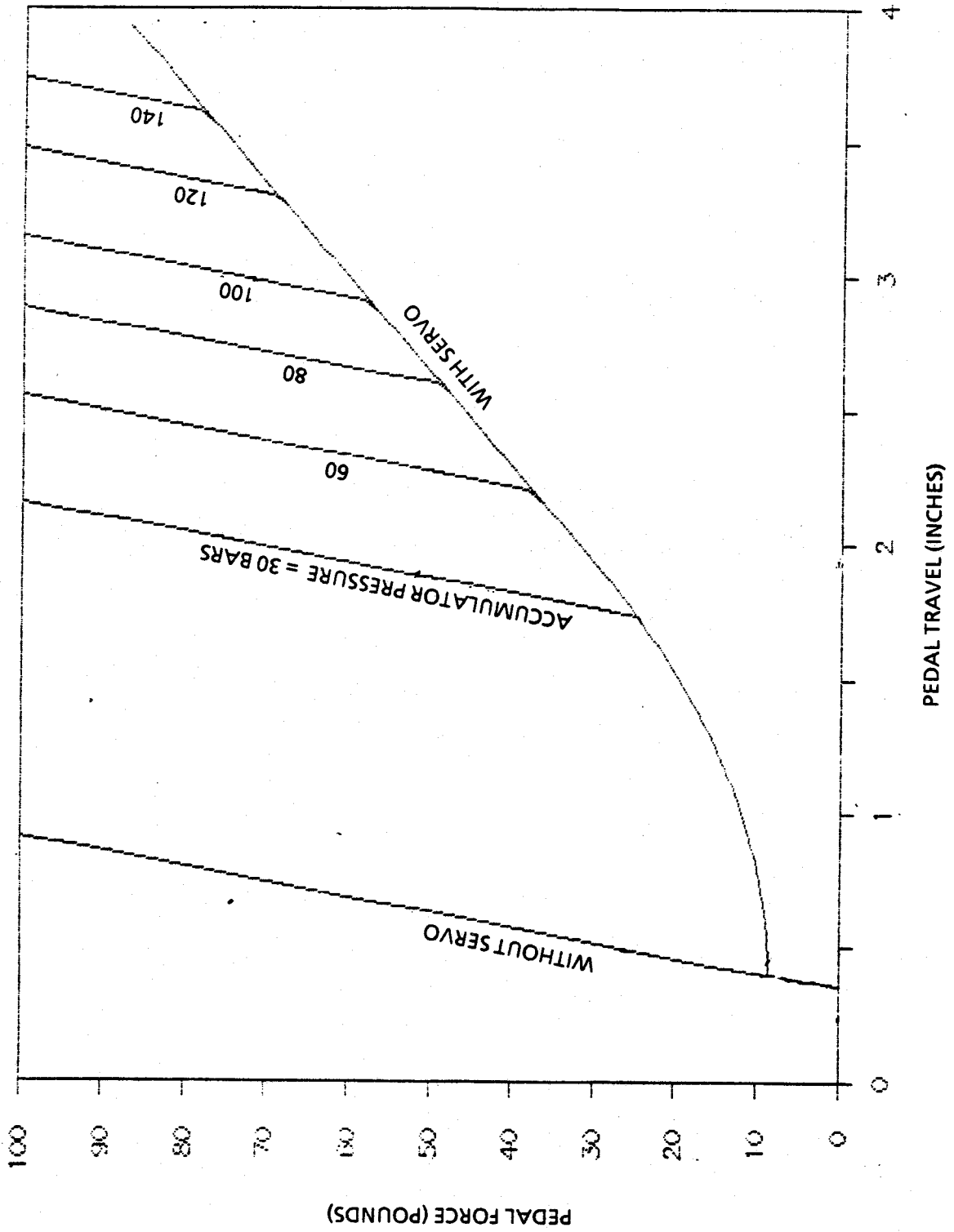

FIGURE C-15. PEDAL FORCE VERSUS PEDAL TRAVEL: HYDRAULIC BOOSTER

fluid reservoir would indicate a system leak. In the case where the master cylinder leaked internally, the failure is not reversible and the brake system would still not operate after the incident.

The brake system's hydraulic power assist is capable of temporarily malfunctioning. If the power-assist system was to malfunction, the required brake-pedal pressure would be about 4.6 times the normal (assist working) braking force required. This would make the system seemingly unresponsive, but enough force could still be applied by the driver to stop the vehicle.

C.6.1 Servo Assist Malfunction and Recovery

One type of temporary failure of the hydraulic assist is reversible. If the brake accumulator was drained fully on start-up and the driver immediately shifted the vehicle into gear and pumped the brake pedal faster than the central hydraulic pump could restore the accumulator pressure, the assist would be inoperable (degraded). However, given time, the pump would restore the fluid level and pressure in the accumulator, and the brake-assist system would operate normally. The amount of time the system needs to restore the accumulator pressure and allow the power assist to operate normally depends upon the empty accumulator gas pressure.

LIST OF SYMBOLS

α	=	Hydraulic pump volumetric efficiency
Δ	=	Volume of fluid displaced per brake-pedal depression
A_a	=	Cross-sectional area of assist chamber
A_s	=	Cross-sectional area of spool valve chamber
A_t	=	Cross-sectional area of piston, total
F_b	=	Force applied by boost servo
F_s	=	Force applied to spool valve from brake pedal
F_{sv}	=	Force due to pressure in spool valve chamber
ΔF_{sv}	=	Change in force due to pressure in spool valve chamber
k	=	Proportionality constant
n	=	Exponent in ideal gas equation
N	=	Number of brake-pedal depressions
P	=	Hydraulic fluid or gas pressure
P_B	=	Pressure of gas in accumulator during bleed-down
P_E	=	Pressure of gas in accumulator empty
P_f	=	Fluid pressure in assist chamber
P_F	=	Pressure of gas in accumulator full
P_L	=	Pressure of gas in accumulator during loading
q	=	Volume flow rate from hydraulic pump
q_o	=	Volume flow rate from hydraulic pump at idle (850 RPM)
RPM	=	Engine speed (revolutions per minute)
V_E	=	Volume of gas in accumulator empty
V_F	=	Volume of gas in accumulator full

APPENDIX D

ENGINE SURGE RESULTS OF A TEST VEHICLE

D.1 INTRODUCTION

In late March 1987, NHTSA contacted TSC concerning a phoned-in complaint of an engine surging problem in a 1984 Audi 5000S. At the request of NHTSA a meeting was arranged with the owners of the vehicle to discuss the complaint and arrange for use of the car for evaluation. The following paragraphs discuss the complaint, tests, and results that TSC observed.

D.2 SUDDEN ACCELERATION HISTORY OF THE TEST VEHICLE

In an interview by TSC the owners reported the following:

The first incident that was noticed by Driver A occurred in November 1986. An abrupt engine surge was noticed right after a "cold start." A few weeks later, Driver A came out of a dry cleaners (warm engine) and started the car in park without being near the pedals; the car surged to approximately 4000 RPM. Driver A shut off the vehicle and started it again, and it appeared normal. Since then, the surges have become more frequent and sometimes occur with the car in gear.

The latest incident occurred in April at a red light with the car in gear. The incidents happen with the engine hot or cold, but seem to happen more often when the driver's foot is on the brake.

Driver B has also experienced engine surges, and during one incident allowed the vehicle to accelerate on its own. The speed went from approximately 20 or 25 mph to 35 mph in a short time before braking was necessary for traffic. Both drivers reported that they noticed repetitious surges (up and down engine speed in short intervals). The brakes have always worked.

During service in November 1986, the Audi dealer installed the shift-interlock. After complaining of the engine surges, the idle-stabilizer valve was replaced by the dealer in January. No other service relating to this problem has been performed. The events continued and may have gotten worse after the valve replacement.

D.3 VEHICLE

TSC examined the vehicle at the home of the owners. During a warm start (the car had been sitting for approximately 1 hour), the engine surged to 2500 RPM for 2 to 3 seconds after the engine had been running for 10 or 15 seconds. The engine was losing coolant and sounded as if it had an exhaust manifold leak. We also noted that the cruise control switch was "on" although the owners stated they seldom used the cruise control and normally left it on "off." The owners agreed to let TSC borrow the vehicle for testing.

D.4 TSC TESTS AND RESULTS

On April 13, the 1984 Audi 5000 was driven to TSC. During the drive the car performed routinely. After further examination, it was determined that the vehicle was in good condition except for the water pump and exhaust leaks previously noted. All other engine systems, including brakes and cruise control, appeared to function normally. The vehicle was instrumented with a portable computer to sample and record the inputs and outputs from the idle-stabilizer electronic control unit. This idle-stabilizer control unit is located under the dashboard (driver's side), and was manufactured by VDO (Part No. 44 3907393D).

The sample and recording system is shown in block diagram in Figure D-1. In order to observe transient phenomena, the computer was set to provide one sample every 1.3 seconds. Software was written to sample the inputs, which were 1) throttle position, 2) air-conditioner clutch, 3) engine temperature, 4) cruise control, 5) engine speed, and 6) the output to the idle-stabilizer valve. Inputs 1) through 4) are basically on-off switches and are recorded as 0 or 1 respectively. Engine speed was recorded in RPM and the output to the idle-stabilizer valve was recorded in amps. Approximately 3 days were required for installation and debugging of the sampling system. During this time (April 13 to 16), no engine surges were observed while running and driving the car. On the morning of April 16th (a cloudy, rainy day) the first surge was observed and recorded. Two other surges were observed that morning but were not recorded due to system problems. Other engine surges were observed and recorded on April 17, 18, and 19 as shown in the Table D-1 summary. In total, 10 incidents were observed and 7 recorded during approximately 30 hours of driving by 3 different TSC personnel over 5 days (including a weekend). The start-and-stop driving modes were emphasized as these seemed to be the conditions under which the engine surges were most likely to occur.

All inputs and output, as well as dates and times, were continuously recorded. Table D-2 is a summary of the seven recorded incidents showing the date, time, operator, and status of the various inputs and the output.

THR = throttle valve position
1 = closed 0 = open

A/C = air-conditioner clutch
1 = on 0 = off

TSE = engine temperature sensor
1 = <40° C 0 = >40° C

CRU = cruise control
1 = on 0 = off

TACH = engine speed in RPM

STAB = amperage to stabilizer valve (232 = 2.32 amps)

Table D-3 shows a more complete record before and after each incident. In all incidents, the output current to the coil of the idle-stabilizer valve increased to approximately 2.2 amps with no change in the status of the input signals. (The valve normally requires 1.3 amps to be fully opened.) Seven of the ten incidents occurred with the engine warm and the gear selector in park. Three incidents occurred with the gear selector in drive: one while under way (Incident #8) and two while stopped at a red light (Incidents #7 and #10). The incidents varied in time from 1 to 6 seconds. Incidents #4 and #7 were double incidents in that the amperage to the valve increased to 2.2 amps and then decreased for 1 second to normal (approximately 0.5 amps), and then suddenly increased again. In park, engine speed during the incidents increased from normal idle (750 to 800 RPM) to between 2500 RPM and

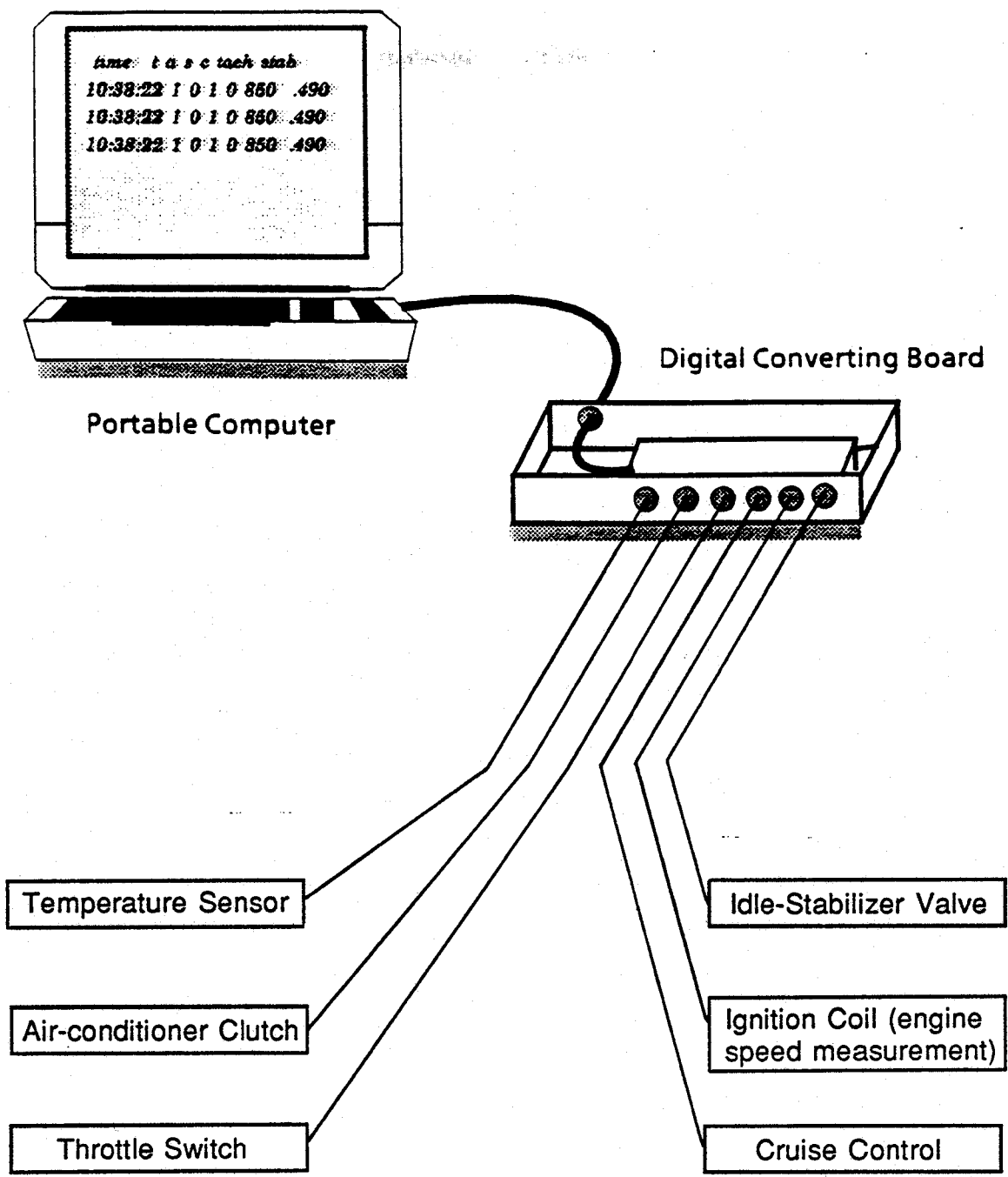

FIGURE D-1. SAMPLE AND RECORDING SYSTEM

TABLE D-1. ENGINE SURGE SUMMARY

Incident #	Date	Time	Gear	Comments
1	4/16/87	10:32:12 10:32:18	park	
2	4/16/87	14:29:00 14:29:00	park	not recorded board fault
3	4/16/87	14:29:00 14:29:00	park	not recorded board fault
4	4/16/87	14:56:17 14:56:25	park	
5	4/16/87	15:00:00 15:00:00	park	not recorded
6	4/16/87	15:20:28 15:20:29	park	
7	4/17/87	10:38:14 10:38:22	drive	stopped at red light
8	4/17/87	12:03:50 12:03:51	drive	throttle opened
9	4/18/87	15:21:56 15:21:58	park	
10	4/19/87	17:17:11 17:17:13	drive	

TABLE D-2. SUMMARY OF INCIDENTS

TIME	THR	A/C	TSE	CRU	TACH	STAB	DATE	OPERATOR
19:32:12	1	0	1	0	1128	232	04/16/87	CBW
19:32:14	1	0	1	0	2328	231	04/16/87	CBW
19:32:15	1	0	1	0	2664	231	04/16/87	CBW
19:32:16	1	0	1	0	2712	231	04/16/87	CBW
14:56:18	1	0	1	0	2304	222	04/16/87	CBW
14:56:22	1	0	1	0	1632	220	04/16/87	CBW
15:20:28	1	0	1	0	1032	226	04/16/87	CBW
10:38:17	1	0	1	0	1632	224	04/17/87	JKP
10:38:18	1	0	1	0	1752	224	04/17/87	JKP
10:38:20	1	0	1	0	1728	222	04/17/87	JKP
10:38:22	1	0	1	0	1800	221	04/17/87	JKP
12:03:51	0	0	1	0	3144	218	04/17/87	JKP
15:21:58	1	0	1	0	1032	211	04/20/87	GAC
17:17:13	1	0	1	0	840	200	04/20/87	GAC

TABLE D-3. COMPLETE RECORD BEFORE AND AFTER INCIDENT
INCIDENT #1

TIME	THR	A/C	TSE	CRU	TACH	STAB	DATE	OPERATOR
19:32:06	1	0	1	0	1152	56	04/16/87	CBW
19:32:07	1	0	1	0	1032	52	04/16/87	CBW
19:32:09	1	0	1	0	984	47	04/16/87	CBW
19:32:10	1	0	1	0	744	53	04/16/87	CBW
19:32:11	1	0	1	0	744	56	04/16/87	CBW
19:32:12	1	0	1	0	1128	232	04/16/87	CBW
19:32:14	1	0	1	0	2328	231	04/16/87	CBW
19:32:15	1	0	1	0	2664	231	04/16/87	CBW
19:32:16	1	0	1	0	2712	231	04/16/87	CBW
19:32:18	1	0	1	0	2520	50	04/16/87	CBW
19:32:19	1	0	1	0	888	56	04/16/87	CBW
19:32:20	1	0	1	0	768	68	04/16/87	CBW
19:32:22	1	0	1	0	1152	47	04/16/87	CBW
19:32:23	1	0	1	0	768	52	04/16/87	CBW
19:32:24	1	0	1	0	768	53	04/16/87	CBW
19:32:25	1	0	1	0	840	50	04/16/87	CBW
19:32:27	1	0	1	0	816	51	04/16/87	CBW
19:32:28	1	0	1	0	840	50	04/16/87	CBW
19:32:29	1	0	1	0	816	51	04/16/87	CBW
19:32:31	1	0	1	0	792	50	04/16/87	CBW
19:32:32	1	0	1	0	792	49	04/16/87	CBW
19:32:33	1	0	1	0	768	50	04/16/87	CBW
19:32:35	1	0	1	0	840	49	04/16/87	CBW
19:32:36	1	0	1	0	792	51	04/16/87	CBW
19:32:37	1	0	1	0	864	50	04/16/87	CBW
19:32:38	1	0	1	0	816	49	04/16/87	CBW
19:32:40	1	0	1	0	816	50	04/16/87	CBW

TABLE D-3. COMPLETE RECORD BEFORE AND AFTER INCIDENT (continued)
INCIDENT #4

TIME	THR	A/C	TSE	CRU	TACH	STAB	DATE	OPERATOR
14:56:00	1	0	1	0	864	52	04/16/87	CBW
14:56:01	1	0	1	0	792	52	04/16/87	CBW
14:56:02	1	0	1	0	912	50	04/16/87	CBW
14:56:04	1	0	1	0	912	51	04/16/87	CBW
14:56:05	1	0	1	0	888	51	04/16/87	CBW
14:56:06	1	0	1	0	888	50	04/16/87	CBW
14:56:08	1	0	1	0	840	52	04/16/87	CBW
14:56:09	1	0	1	0	888	51	04/16/87	CBW
14:56:10	1	0	1	0	840	52	04/16/87	CBW
14:56:12	1	0	1	0	912	51	04/16/87	CBW
14:56:13	1	0	1	0	912	52	04/16/87	CBW
14:56:14	1	0	1	0	912	50	04/16/87	CBW
14:56:16	1	0	1	0	936	49	04/16/87	CBW
14:56:17	1	0	1	0	864	135	04/16/87	CBW
14:56:18	1	0	1	0	2304	222	04/16/87	CBW
14:56:20	1	0	1	0	3072	56	04/16/87	CBW
14:56:21	1	0	1	0	1416	48	04/16/87	CBW
14:56:22	1	0	1	0	1632	220	04/16/87	CBW
14:56:24	1	0	1	0	2712	50	04/16/87	CBW
14:56:25	1	0	1	0	1272	52	04/16/87	CBW
14:56:26	1	0	1	0	816	51	04/16/87	CBW
14:56:28	1	0	1	0	840	52	04/16/87	CBW
14:56:29	1	0	1	0	888	50	04/16/87	CBW
14:56:30	1	0	1	0	936	48	04/16/87	CBW
14:56:32	1	0	1	0	912	48	04/16/87	CBW

TABLE D-3. COMPLETE RECORD BEFORE AND AFTER INCIDENT (continued)
INCIDENT #6

TIME	THR	A/C	TSE	CRU	TACH	STAB	DATE	OPERATOR
15:20:15	1	0	1	0	720	44	04/16/87	CBW
15:20:16	1	0	1	0	792	44	04/16/87	CBW
15:20:17	1	0	1	0	792	48	04/16/87	CBW
15:20:19	1	0	1	0	792	46	04/16/87	CBW
15:20:20	1	0	1	0	768	45	04/16/87	CBW
15:20:21	1	0	1	0	744	45	04/16/87	CBW
15:20:23	1	0	1	0	768	45	04/16/87	CBW
15:20:24	1	0	1	0	720	45	04/16/87	CBW
15:20:25	1	0	1	0	720	46	04/16/87	CBW
15:20:27	1	0	1	0	816	44	04/16/87	CBW
15:20:28	1	0	1	0	1032	226	04/16/87	CBW
15:20:29	1	0	1	0	2832	46	04/16/87	CBW
15:20:31	1	0	1	0	912	46	04/16/87	CBW
15:20:32	1	0	1	0	792	45	04/16/87	CBW
15:20:33	1	0	1	0	744	45	04/16/87	CBW
15:20:34	1	0	1	0	768	44	04/16/87	CBW
15:20:36	1	0	1	0	720	45	04/16/87	CBW
15:20:37	1	0	1	0	744	45	04/16/87	CBW
15:20:39	1	0	1	0	720	43	04/16/87	CBW
15:20:40	1	0	1	0	744	45	04/16/87	CBW
15:20:41	1	0	1	0	720	44	04/16/87	CBW
15:20:42	1	0	1	0	744	46	04/16/87	CBW
15:20:44	1	0	1	0	720	46	04/16/87	CBW
15:20:45	1	0	1	0	744	45	04/16/87	CBW

TABLE D-3. COMPLETE RECORD BEFORE AND AFTER INCIDENT (continued)
 INCIDENT #7

TIME	THR	A/C	TSE	CRU	TACH	STAB	DATE	OPERATOR
10:38:00	1	0	1	0	936	57	04/17/87	JKP
10:38:01	1	0	1	0	936	57	04/17/87	JKP
10:38:02	1	0	1	0	936	56	04/17/87	JKP
10:38:04	1	0	1	0	912	56	04/17/87	JKP
10:38:05	1	0	1	0	936	55	04/17/87	JKP
10:38:06	1	0	1	0	936	55	04/17/87	JKP
10:38:08	1	0	1	0	936	57	04/17/87	JKP
10:38:09	1	0	1	0	912	56	04/17/87	JKP
10:38:10	1	0	1	0	936	57	04/17/87	JKP
10:38:12	1	0	1	0	912	58	04/17/87	JKP
10:38:13	1	0	1	0	960	56	04/17/87	JKP
10:38:14	1	0	1	0	984	55	04/17/87	JKP
10:38:16	1	0	1	0	960	148	04/17/87	JKP
10:38:17	1	0	1	0	1632	224	04/17/87	JKP
10:38:18	1	0	1	0	1752	224	04/17/87	JKP
10:38:20	1	0	1	0	1728	222	04/17/87	JKP
10:38:21	1	0	1	0	1680	56	04/17/87	JKP
10:38:22	1	0	1	0	1800	221	04/17/87	JKP
10:38:24	0	0	1	0	2472	72	04/17/87	JKP
10:38:25	0	0	1	0	1944	47	04/17/87	JKP
10:38:26	0	0	1	0	1488	47	04/17/87	JKP
10:38:28	0	0	1	0	1416	53	04/17/87	JKP
10:38:29	1	0	1	0	1104	48	04/17/87	JKP
10:38:30	1	0	1	0	960	49	04/17/87	JKP
10:38:32	1	0	1	0	840	52	04/17/87	JKP
10:38:33	1	0	1	0	912	52	04/17/87	JKP
10:38:34	0	0	1	0	2232	47	04/17/87	JKP
10:38:36	0	0	1	0	2088	49	04/17/87	JKP
10:38:37	0	0	1	0	1776	48	04/17/87	JKP
10:38:38	0	0	1	0	1872	48	04/17/87	JKP
10:38:39	0	0	1	0	2016	47	04/17/87	JKP
10:38:41	0	0	1	0	2352	47	04/17/87	JKP
10:38:42	0	0	1	0	2328	45	04/17/87	JKP
10:38:43	0	0	1	0	2304	46	04/17/87	JKP
10:38:45	0	0	1	0	1536	51	04/17/87	JKP

TABLE D-3. COMPLETE RECORD BEFORE AND AFTER INCIDENT (continued)
INCIDENT #8

TIME	THR	A/C	TSE	CRU	TACH	STAB	DATE	OPERATOR
12:03:35	1	0	1	0	960	58	04/17/87	JKP
12:03:37	1	0	1	0	912	59	04/17/87	JKP
12:03:38	1	0	1	0	936	59	04/17/87	JKP
12:03:39	1	0	1	0	912	58	04/17/87	JKP
12:03:40	1	0	1	0	1200	47	04/17/87	JKP
12:03:42	0	0	1	0	2424	47	04/17/87	JKP
12:03:43	0	0	1	0	2784	48	04/17/87	JKP
12:03:44	0	0	1	0	2976	47	04/17/87	JKP
12:03:46	0	0	1	0	2808	48	04/17/87	JKP
12:03:47	0	0	1	0	2952	48	04/17/87	JKP
12:03:48	0	0	1	0	3024	45	04/17/87	JKP
12:03:50	0	0	1	0	3096	46	04/17/87	JKP
12:03:51	0	0	1	0	3144	218	04/17/87	JKP
12:03:52	0	0	1	0	2760	47	04/17/87	JKP
12:03:54	0	0	1	0	2592	47	04/17/87	JKP
12:03:55	0	0	1	0	2448	46	04/17/87	JKP
12:03:56	0	0	1	0	2352	48	04/17/87	JKP
12:03:58	0	0	1	0	1992	48	04/17/87	JKP
12:03:59	0	0	1	0	1872	47	04/17/87	JKP
12:04:00	0	0	1	0	1848	47	04/17/87	JKP
12:04:02	0	0	1	0	1896	47	04/17/87	JKP
12:04:03	0	0	1	0	1848	46	04/17/87	JKP
12:04:04	0	0	1	0	2184	47	04/17/87	JKP

TABLE D-3. COMPLETE RECORD BEFORE AND AFTER INCIDENT (continued)
 INCIDENT #9

TIME	THR	A/C	TSE	CRU	TACH	STAB	DATE	OPERATOR
15:21:55	1	0	1	0	888	52	04/20/87	GAC
15:21:56	1	0	1	0	912	53	04/20/87	GAC
15:21:58	1	0	1	0	1032	211	04/20/87	GAC
15:21:59	1	0	1	0	912	55	04/20/87	GAC
15:22:00	1	0	1	0	888	53	04/20/87	GAC
15:22:02	1	0	1	0	960	56	04/20/87	GAC
15:22:03	1	0	1	0	888	53	04/20/87	GAC
15:22:04	1	0	1	0	912	52	04/20/87	GAC
15:22:06	1	0	1	0	936	51	04/20/87	GAC
15:22:07	1	0	1	0	888	52	04/20/87	GAC
15:22:08	1	0	1	0	816	50	04/20/87	GAC
15:22:10	1	0	1	0	888	51	04/20/87	GAC

TABLE D-3. COMPLETE RECORD BEFORE AND AFTER INCIDENT (continued)
INCIDENT #10

TIME	THR	A/C	TSE	CRU	TACH	STAB	DATE	OPERATOR
17:17:01	1	0	1	0	744	53	04/20/87	GAC
17:17:02	1	0	1	0	816	54	04/20/87	GAC
17:17:03	1	0	1	0	792	56	04/20/87	GAC
17:17:05	1	0	1	0	744	54	04/20/87	GAC
17:17:06	1	0	1	0	816	55	04/20/87	GAC
17:17:07	1	0	1	0	864	57	04/20/87	GAC
17:17:09	1	0	1	0	816	55	04/20/87	GAC
17:17:10	1	0	1	0	816	56	04/20/87	GAC
17:17:11	1	0	1	0	792	57	04/20/87	GAC
17:17:13	1	0	1	0	840	200	04/20/87	GAC
17:17:14	1	0	1	0	816	55	04/20/87	GAC
17:17:15	1	0	1	0	840	57	04/20/87	GAC
17:17:17	1	0	1	0	864	55	04/20/87	GAC
17:17:18	1	0	1	0	768	54	04/20/87	GAC
17:17:19	1	0	1	0	840	54	04/20/87	GAC
17:17:21	1	0	1	0	1008	49	04/20/87	GAC
17:17:22	0	0	1	0	1032	49	04/20/87	GAC
17:17:23	1	0	1	0	744	55	04/20/87	GAC
17:17:25	1	0	1	0	792	54	04/20/87	GAC
17:17:26	0	0	1	0	1128	48	04/20/87	GAC

3000 RPM. During Incident #8 with the throttle open, the engine speed increased only slightly, and in fact, was not noticeable to the driver as he was accelerating up a hill. An increase of approximately 50 RPM was recorded during Incident #10, which was also hardly noticeable. In both of these "drive" incidents, the current increase was for only 1 second. The third "drive" incident (#7), however, was very apparent and occurred just before the driver accelerated from a red light.

TSC performed further tests to evaluate the effect of a fully opened idle-stabilizer valve on vehicle performance. For these tests, 1.3 amps of current were supplied to the stabilizer valve by a battery pack. A fully open valve caused this Audi to reach speeds of 45 mph in drive and 25 mph in reverse within 30 to 40 seconds. When the valve was opened at 60 mph the vehicle speed increased quickly to 65 mph and felt as if the cruise control had engaged. The electronic control box was examined and the components were found to be discolored, possibly due to excess heat; these components also exhibited a burnt odor.

APPENDIX E

DRIVER COMPARTMENT MEASUREMENTS: 1975-1981

DOMESTIC VEHICLES

NU	YR	MODEL	MILES	SER	ENG.	CRCT	A1	A2	A4	A5
1	81	PACER	16634	1AMCA0851BK146032	L-6	N	N	.	.	.
2	74	AMB	102591	A4A851H526158	V-8	N	N	.	.	.
3	74	MAT	98267	A4A161A767810	L-6	N	N	.	.	.
4	79	NY	4695	TH42K9B921306	V-8	Y	N	.	.	.
5	80	NEWP	21576	TM41GAF106715	V-8	N	N	.	.	.
6	80	CORD	33891	5H22GAD089541	V-8	Y	C/V	S	B	N
7	78	LEBARON	52681	FH22G8B523151	V-8	N	N	.	.	.
8	76	IMP.	60001	VH22T6A542168	V-8	Y	C/V	S	B	N
9	74	N.Y	72136	CH42M4C671890	A	N	N	.	.	.
10	76	NEWP	91561	CM41M6C207152	V-8	N	N	.	.	.
11	80	ST.R	25725	EH43KAB210501	V-8	N	N	.	.	.
12	78	DIP	41861	GH22086126814	L-6	N	N	.	.	.
13	75	MONO	110423	DM41G5B532178	V-8	N	N	.	.	.
14	75	CORO	121011	WM21K5P115812	V-8	N	N	.	.	.
15	76	CHAR	62552	X522KGR113654	V-8	N	N	.	.	.
16	77	MONA	68562	DM41G7B891062	V-8	N	N	.	.	.
17	79	VOL	40415	HL41G9F123171	V-8	N	N	R	B	.
18	75	DART	98686	LM21C5F697541	L-6	N	N	.	.	.
19	77	FURY	82318	PH22G7A765126	V-8	N	N	.	.	.
20	73	FURY	145691	RL41M3A951232	V-8	N	N	.	.	.
21	78	CONT.	23414	8Y815876016	V-8	Y	N	.	.	.
22	79	MARK V	26322	F94895619344F	V-8	Y	N	.	.	.
23	79	VERS	33739	F9W84F654390F	V-8	Y	C/R	S	B	.
24	75	MK.IV	72652	F5Y894089F	V-8	Y	C	S	B	.
25	79	GAL	52302	F9A63F144853F	V-8	N	N	.	.	.
26	73	LTD	89088	F97B63S276874F	V-8	N	N	.	.	.
27	76	GAL	103352	6B765194932	V-8	N	N	.	.	.
28	80	LTD2	39651	BE71BA678125	V-8	N	N	.	.	.
29	80	TBIR	41565	FT71BA153478	V-8	Y	N	.	.	.
30	74	TBIR	125678	4Y87A115130	V-8	N	N	.	.	.
31	73	TOR	78028	44425218914F	V-8	N	N	.	.	.
32	76	MAV	61478	FOE91612625	L-6	N	N	.	.	.
33	80	FRMT	42589	OE91A126801	L-4	N	N	.	.	.
34	79	GRAN	48961	OF9191160895	L-6	N	N	.	.	.
35	81	MARQ	10291	1MEBP83F9CZ625031	V-8	N	N	.	.	.
36	76	MARQ	50248	6274S527622	V-8	N	N	.	.	.
37	73	MONT	138164	3B62A514151	V-8	N	N	.	.	.
38	73	MONT	116688	3401L340962	V-8	N	N	.	.	.
39	79	COUG	57950	9H93H942332	V-8	N	N	.	.	.
40	78	DEV	67118	6D6958Q111516	V-8	Y	V	S	B	N
41	79	SEV	51233	6569B9Q243571	V-8	Y	V/C	F	B	N
42	79	ELD	81679	6L47T9Q235141	V-8	Y	V/C	F	R	N
43	77	FLW	41115	6F2357Q688115	V-8	Y	V/C	S	B	N
44	73	ELD	121677	6EL67R3Q221541	V-8	Y	N	.	.	.
45	73	CALA	101533	6CC49R39198215	V-8	N	N	.	.	.
46	80	CAP	35069	1N47GAF268105	V-8	N	N	.	.	.
47	79	IMP	42567	L47G95293881	V-8	N	N	.	.	.
48	79	MALI	27570	IT27M9B067881	V-8	N	N	.	.	.
49	80	M.C	51727	1M477AF952110	V-6	N	N	.	.	.
50	73	CAP	101067	1H47K5P174999	V-8	Y	N	.	.	.
51	73	IMP	130711	1I44H3P067118	V-8	N	N	.	.	.
52	76	M.C	57276	1H57U6B6078081	V-8	N	N	.	.	.

NU	YR	MODEL	B1	B2	B3	B4	C1	C2	P1	P2	P3	A
1	81	PACER	20	17	19	20	.	.	5.1	6	6.8	22
2	74	AMB	19	16	17	22	.	.	5.4	6.1	6.9	15
3	74	MAT	18	14	16	16	.	.	5.3	6.1	7	20
4	79	NY	25	27	27	26	.	.	5	8.1	10	25
5	80	NEWP	21	14	13	19	.	.	6.1	8.1	10.2	35
6	80	CORD	20	20	19	16	N	N	4.2	5.6	7	11
7	78	LEBARON	20	20	16	18	N	N	5	5.8	7.1	12
8	76	IMP.	28	28	24	26	N	N	6.8	7.9	9	24
9	74	N.Y	20	20	12	19	.	.	6	7.3	8.6	25
10	76	NEWP	15	15	15	15	.	.	6.1	7	7.9	25
11	80	ST.R	19	19	22	26	.	.	5	8	9.4	25
12	78	DIP	14	14	12	13	.	.	4.2	5	6.1	23
13	75	MONO	0	0	16	13	.	.	4.7	5.9	6.5	20
14	75	CORO	9	9	9	12	.	.	4.5	6	6.9	25
15	76	CHAR	13	13	13	13	.	.	3.8	5	6.7	-45
16	77	MONA	16	16	14	12	.	.	4.6	5.8	6.9	5
17	79	VOL	16	12	13	13	N	N	3	3.8	4.2	15
18	75	DART	15	14	16	16	.	.	4.8	5.9	7	15
19	77	FURY	18	15	15	16	.	.	6.7	9	11.1	15
20	73	FURY	0	0	0	0	.	.	5	6.5	8.2	0
21	78	CONT.	25	25	26	30	.	.	5.7	8	11	20
22	79	MARK V	28	28	27	36	.	.	6	6.8	7.9	20
23	79	VERS	20	22	22	21	Y4	Y4	4.2	5.1	5.9	20
24	75	MK. IV	21	21	21	25	.	.	5.4	7.1	8	20
25	79	GAL	0	0	0	16	.	.	3.9	4.9	6.1	25
26	73	LTD	16	16	15	13	.	.	5.1	6.8	9	15
27	76	GAL	0	0	0	0	.	.	4	5.9	7.8	20
28	80	LTD2	30	32	30	31	.	.	3	5	8	9
29	80	TBIR	30	32	30	31	.	.	4	7	9	9
30	74	TBIR	28	78	26	31	.	.	6.8	9	11	15
31	73	TOR	18	18	17	19	.	.	5.4	6.7	8.1	68
32	76	MAV	26	27	25	26	.	.	4	6	7	9
33	80	FRMT	26	26	29	28	.	.	4	5.5	9	10
34	79	GRAN	25	25	18	28	.	.	6.7	8.1	9.3	10
35	81	MARQ	30	31	31	33	.	.	6	8.1	9.4	-20
36	76	MARQ	19	19	22	22	.	.	6.7	9.1	10	73
37	73	MONT	13	13	15	16	.	.	7	8.3	9.8	76
38	73	MONT	20	20	20	19	Y4	Y4	5	7.1	8.6	54
39	79	COUG	22	22	19	19	.	.	5.8	7	8.3	76
40	78	DEV	32	32	33	34	Y4	Y4	6.8	8	9.9	32
41	79	SEV	0	0	0	24	Y5	Y5	7.3	9.8	12.4	80
42	79	ELD	0	0	0	22	Y5	Y5	8	9.6	14.1	80
43	77	FLW	0	0	29	34	Y5	Y5	8.1	9.3	10.9	41
44	73	ELD	0	0	0	31	.	.	8.6	10.2	13.9	81
45	73	CALA	0	0	0	19	.	.	8.5	9.8	11	0
46	80	CAP	0	0	0	13	.	.	5.3	6.8	9.1	45
47	79	IMP	0	0	0	10	.	.	6	8.3	9.5	45
48	79	MALI	14	15	14	14	.	.	3.1	4	5.2	-35
49	80	M.C	16	16	15	19	.	.	3.3	4.1	5.5	-35
50	73	CAP	12	12	13	15	.	.	5.1	6	7.6	80
51	73	IMP	0	0	0	13	.	.	4.9	5.5	6.2	45
52	76	M.C	0	0	0	15	.	.	5	6.2	8	40

NU	YR	MODEL	B	C	D1	D2	E	F	G1	G2
1	81	PACER	47	47	18	14	142	59	90	40
2	74	AMB	54	48	11	21	121	57	86	52
3	74	MAT	55	48	14	19	121	57	90	50
4	79	NY	70	40	5	10	100	40	40	22
5	80	NEWP	85	40	20	5	100	40	39	25
6	80	CORD	70	50	5	6	100	40	40	21
7	78	LEBARON	70	50	10	11	100	40	48	23
8	76	IMP.	72	90	20	21	99	40	40	17
9	74	N.Y	70	80	20	21	100	40	40	19
10	76	NEWP	70	40	20	21	100	40	39	13
11	80	ST.R	70	50	0	8	100	40	43	18
12	78	DIP	70	40	0	5	100	40	46	21
13	75	MONO	70	50	9	0	100	40	47	23
14	75	CORO	70	50	6	7	100	40	55	9
15	76	CHAR	70	50	0	6	100	40	50	25
16	77	MONA	70	50	4	2	100	40	45	30
17	79	VOL	70	50	0	0	100	40	50	5
18	75	DART	70	50	0	6	100	40	43	28
19	77	FURY	70	40	6	7	100	40	40	8
20	73	FURY	70	50	6	7	100	40	50	19
21	78	CONT.	49	40	5	11	155	39	76	35
22	79	MARK V	48	40	10	11	155	40	80	43
23	79	VERS	48	40	0	0	155	39	58	33
24	75	MK. IV	48	40	11	16	155	39	70	42
25	79	GAL	60	23	10	11	155	38	77	22
26	73	LTD	60	23	10	9	155	39	76	15
27	76	GAL	48	40	25	12	155	39	80	38
28	80	LTD2	51	30	11	6	135	65	73	58
29	80	TBIR	52	30	11	6	135	65	76	52
30	74	TBIR	51	40	22	12	155	39	65	41
31	73	TOR	56	40	29	26	155	39	48	21
32	76	MAV	72	30	16	12	135	49	96	65
33	80	FRMT	73	40	25	17	155	39	82	70
34	79	GRAN	68	40	28	26	155	39	88	52
35	81	MARQ	67	40	16	10	155	50	77	29
36	76	MARQ	67	40	28	11	155	39	81	42
37	73	MONT	68	40	28	14	155	50	78	45
38	73	MONT	67	40	10	9	155	39	72	49
39	79	COUG	65	40	9	12	135	50	83	51
40	78	DEV	73	79	18	12	233	61	69	56
41	79	SEV	64	78	61	52	195	67	69	33
42	79	ELD	63	78	66	58	195	67	66	38
43	77	FLW	69	68	25	14	231	46	48	32
44	73	ELD	61	65	50	10	231	42	48	21
45	73	CALA	60	65	50	10	233	47	45	15
46	80	CAP	67	70	0	10	233	60	63	20
47	79	IMP	67	70	0	10	150	60	63	20
48	79	MALI	56	37	10	12	135	47	64	3
49	80	M.C	56	37	10	12	135	47	65	5
50	73	CAP	45	70	6	6	150	65	59	28
51	73	IMP	79	67	10	10	150	65	50	30
52	76	M.C	76	47	10	0	137	57	58	23

NU	YR	MODEL	G3	G1A	G2A	G3A	BRK
1	81	PACER	10	.	.	.	M*
2	74	AMB	16	.	.	.	M
3	74	MAT	19	.	.	.	M
4	79	NY	7	40	5	-10	.
5	80	NEWP	10	39	10	-7	.
6	80	CORD	6	40	12	0	.
7	78	LEBARON	10	48	8	-11	.
8	76	IMP.	2	40	5	-9	.
9	74	N.Y	3	40	6	-10	.
10	76	NEWP	5	37	4	-10	.
11	80	ST.R	2	43	3	-13	.
12	78	DIP	6	46	21	6	.
13	75	MONO	0	47	12	-11	.
14	75	CORO	-5	55	9	-40	.
15	76	CHAR	19	50	25	-30	.
16	77	MONA	0	45	30	0	.
17	79	VOL	-50	50	-5	-90	.
18	75	DART	2	0	0	0	M
19	77	FURY	-20	40	0	-35	.
20	73	FURY	-8	50	0	-48	.
21	78	CONT.	15	76	21	7	.
22	79	MARK V	26	80	38	15	.
23	79	VERS	18	58	24	8	.
24	75	MK. IV	28	70	31	11	.
25	79	GAL	-7	77	-1	-32	.
26	73	LTD	-10	76	-5	-30	.
27	76	GAL	10	80	21	-21	.
28	80	LTD2	28	73	32	-1	.
29	80	TBIR	30	76	33	0	.
30	74	TBIR	28	65	32	19	.
31	73	TOR	11	48	13	4	.
32	76	MAV	33
33	80	FRMT	51	82	59	35	.
34	79	GRAN	30	88	43	21	.
35	81	MARQ	12	77	10	-11	.
36	76	MARQ	21	81	32	10	.
37	73	MONT	28	78	31	16	.
38	73	MONT	29	72	38	18	.
39	79	COUG	29	83	43	29	.
40	78	DEV	39	69	41	21	.
41	79	SEV	8	69	14	-6	.
42	79	ELD	10	66	19	-2	.
43	77	FLW	14	48	23	6	.
44	73	ELD	0	48	3	-21	.
45	73	CALA	-20	45	0	-45	.
46	80	CAP	-8	63	14	-35	.
47	79	IMP	-5	63	-11	-30	.
48	79	MALI	-20	64	-10	-40	.
49	80	M.C	-22	65	5	-22	.
50	73	CAP	-5	59	10	-35	.
51	73	IMP	-10	50	17	-40	.
52	76	M.C	0	58	6	-25	.

NU	YR	MODEL	MILES	SER	ENG.	CRCT	A1	A2	A4	A5
53	76	CHEV	89115	1629U6F331215	V-8	N	N	.	.	.
54	76	NOVA	84582	1X27U6W431542	V-8	N	N	.	.	.
55	76	CAM	82066	1Q87Q681372	V-8	N	N	.	.	.
56	73	CORV	85610	1767H3D	V-8	N	R	S	R	MO
57	79	LESAB	91327	4N69R9X301210	V-8	N	N	.	.	.
58	77	ELEC	56166	4U69R7Q871162	V-8	N	C/V	S	B	N
59	79	RIVI	32324	4257R9E139282	V-8	Y	N	.	.	.
60	81	CENTU	3721	1G4AH69A1BH106081	V-6	N	V	S	R	N
61	79	REGAL	57822	4J47G9X267110	V-6	N	N	.	.	.
62	75	LESAB	102716	4DN3955Q300715	V-8	N	N	.	.	.
63	76	ELEC	88177	4U39S6X277132	V-8	N	N	.	.	.
64	76	RIV	108701	4287T6X321892	V-8	N	R	S	B	HO
65	76	CENT	83216	4D29C6X452634	V-6	N	N	.	.	.
66	78	CR88	47110	3Q35N8X190261	V-8	N	R	S	D	N
67	80	98	33383	3X69RAX391232	V-8	N	N	.	.	.
68	76	98	100671	3L39R6M197651	V-8	N	N	.	.	.
69	75	98	135688	3U39T5M100677	V-8	N	N	.	.	.
70	78	CUTL	59701	3R47A8240701	V-6	N	N	.	.	.
71	76	CUTL	129073	3J57R6G221310	V-8	N	R	S	D	MH
72	79	TOR	51161	3257R9X729761	V-8	Y	N	.	.	.
73	73	TOR	160715	3Y57W3M297301	V-8	Y	N	.	.	.
74	79	BONN	67781	2N69R9P102136	V-8	N	N	.	.	.
75	80	CAT	20001	2L69RAP865123	V-8	N	R	S	R	MO
76	75	BONN	99109	2P47R5P388671	V-8	N	R	S	B	SO
77	75	CAT	74910	2L69R5P526911	V-8	N	V	S	R	MO
78	73	GP	101433	2K57T3A187945	V-8	N	N	.	.	.
79	80	GP	25111	2H37TAP327101	V-8	N	V	S	R	SO
80	79	LEMAN	14025	2F27A91539920	V-6	N	N	.	.	.
81	75	LEMAN	53519	2D29H5P306519	V-8	N	R	S	R	SO
82	77	OMEGA	50121	3B27G7M371940	V-8	N	N	.	.	.
83	73	APOLL	85514	4XC69D5X220749	L-6	N	N	.	.	.
84	76	STARF	75960	3D0766X292465	L-6	N	R	S	B	N

AVERAGE	68521.2
COUNT	85
MAX	160715
MIN	0
STD	36206.4
SUM	5824308
VAR	1E+09

NU	YR	MODEL	B1	B2	B3	B4	C1	C2	P1	P2	P3	A
53	76	CHEV	0	0	0	18	.	.	6.7	8.1	9.7	27
54	76	NOVA	15	15	13	19	Y4	Y4	3	4	5.1	33
55	76	CAM	11	10	11	12	.	.	2	4	4.5	40
56	73	CORV	16	16	17	17	.	.	5	6.2	8	-40
57	79	LESAB	0	0	0	21	.	.	7.3	8.6	10	27
58	77	ELEC	0	0	0	33	Y4	Y4	7.6	9.1	12.3	71
59	79	RIVI	0	15	0	0	.	.	7.5	9	15	80
60	81	CENTU	11	19	18	21	.	.	4.1	7	8.5	8
61	79	REGAL	21	19	18	18	.	.	6.8	8.1	9.8	8
62	75	LESAB	0	0	0	21	.	.	7.8	9.2	10.1	73
63	76	ELEC	0	0	0	24	.	.	7.6	9.3	10.6	73
64	76	RIV	0	0	0	27	Y3	Y3	8	10.1	13.8	5
65	76	CENT	0	18	0	19	.	.	5	7.2	8.6	42
66	78	CR88	0	0	0	34	Y1	Y3	7	10.5	14	0
67	80	98	0	0	0	28	.	.	6.7	8.9	12.1	0
68	76	98	14	13	14	15	Y2	Y2	7	9.6	11.1	88
69	75	98	0	0	0	26	.	.	8.1	9.7	10.1	78
70	78	CUTL	21	13	21	15	.	.	2	4.5	9	8
71	76	CUTL	16	14	15	16	Y4	Y4	4.2	6.7	8.9	35
72	79	TOR	0	0	0	16	.	.	7.8	9.1	12	80
73	73	TOR	0	0	0	21	.	.	6.7	5.8	13	33
74	79	BONN	0	0	0	19	.	.	6.2	7.5	9.1	25
75	80	CAT	0	0	0	31	Y3	Y3	6.5	9.1	12.8	5
76	75	BONN	18	18	21	18	Y3	Y3	8.7	10.1	12.1	60
77	75	CAT	0	0	18	19	Y3	Y3	4.8	7.6	8.5	25
78	73	GP	0	0	17	19	.	.	5	8	9	20
79	80	GP	20	21	19	23	Y3	Y3	6.3	8.1	9.1	22
80	79	LEMAN	0	0	0	24	.	.	6.7	9.1	11	22
81	75	LEMAN	15	16	16	18	Y3	Y2	5	7.1	9	41
82	77	OMEGA	18	18	18	22	.	.	4.6	6.9	8.6	-7
83	73	APOLL	16	16	16	19	.	.	6.1	8.6	11.1	70
84	76	STARF	17	17	18	21	2	2	4.5	7	9.1	-8

AVERAGE	12.1	12.8	12.6	19.9		5.6	7.2	9.0	28.0
COUNT	85	85	85	85		85	85	85	85
MAX	32	78	33	36		8.7	10.5	15	88
MIN	0	0	0	0		0	0	0	-45
STD	10.3	12.3	10.0	7.6		1.6	1.9	2.5	29.8
SUM	1026	1091	1075	1692		472.3	611.8	765.6	2384
VAR	106.4	151.5	99.7	58.6		2.7	3.4	6.2	886.2

NU	YR	MODEL	B	C	D1	D2	E	F	G1	G2
53	76	CHEV	68	73	74	0	152	60	58	38
54	76	NOVA	70	40	6	11	135	47	69	10
55	76	CAM	58	47	5	5	142	55	36	10
56	73	CORV	60	47	0	0	155	57	55	30
57	79	LESAB	71	68	75	0	152	60	62	21
58	77	ELEC	67	79	0	11	248	61	67	33
59	79	RIVI	63	77	66	58	195	67	60	28
60	81	CENTU	71	56	11	0	137	63	80	33
61	79	REGAL	71	56	15	6	137	63	75	46
62	75	LESAB	60	75	26	9	225	67	56	32
63	76	ELEC	60	75	23	11	225	67	60	35
64	76	RIV	76	79	8	68	233	61	62	39
65	76	CENT	75	68	14	12	155	59	63	38
66	78	CR88	73	79	32	40	233	61	63	25
67	80	98	72	79	15	8	227	61	67	30
68	76	98	45	70	6	7	150	65	62	38
69	75	98	57	77	22	11	248	60	55	33
70	78	CUTL	61	55	16	0	135	61	75	53
71	76	CUTL	75	70	10	10	155	59	55	32
72	79	TOR	63	77	66	58	195	67	64	33
73	73	TOR	74	79	10	0	248	60	60	24
74	79	BONN	177	70	11	13	150	59	68	49
75	80	CAT	72	80	56	37	248	61	65	29
76	75	BONN	86	62	5	7	163	60	60	12
77	75	CAT	176	68	0	3	152	60	60	47
78	73	GP	180	55	0	6	155	60	59	45
79	80	GP	156	68	15	16	155	55	68	33
80	79	LEMAN	156	79	15	16	248	60	68	39
81	75	LEMAN	75	47	15	13	137	59	61	39
82	77	OMEGA	85	30	14	15	98	59	63	41
83	73	APOLL	101	56	12	16	137	47	80	39
84	76	STARF	42	20	14	15	98	59	59	42

AVERAGE	70.7	54.1	17.1	13.24	152.69	51.05	61.6	31.4
COUNT	85	85	85	85	85	85	85	85
MAX	180	90	75	68	248	67	96	70
MIN	0	0	0	0	0	0	0	0
STD	27.6	17.9	17.8	13.57	48.006	11.71	15.4	14.4
SUM	6013	4601	1451	1126	12979	4340	5239	2671
VAR	762.3	321.0	317.6	184.3	2304.6	137.2	237.7	206.9

NU	YR	MODEL	G3	G1A	G2A	G3A	BRK
53	76	CHEV	20	58	27	9	.
54	76	NOVA	5	69	5	-8	.
55	76	CAM	-21	36	0	-21	.
56	73	CORV	0	55	10	-25	.
57	79	LESAB	-5	62	11	-30	.
58	77	ELEC	14	67	18	5	.
59	79	RIVI	8	60	0	-17	.
60	81	CENTU	21	80	21	0	.
61	79	REGAL	19	75	35	5	.
62	75	LESAB	21	56	22	11	.
63	76	ELEC	21	60	28	17	.
64	76	RIV	22	62	26	14	.
65	76	CENT	16	63	21	-2	.
66	78	CR88	-8	63	0	-57	.
67	80	98	12	67	16	0	.
68	76	98	18	62	27	5	.
69	75	98	20	55	21	12	.
70	78	CUTL	35	75	26	-2	.
71	76	CUTL	5	55	26	-1	.
72	79	TOR	11	64	10	-8	.
73	73	TOR	9	60	16	-3	.
74	79	BONN	29	68	29	3	.
75	80	CAT	12	65	14	-3	.
76	75	BONN	-21	60	4	-29	.
77	75	CAT	26	60	31	8	.
78	73	GP	21	59	24	9	.
79	80	GP	16	68	19	0	.
80	79	LEMAN	13	68	23	-4	.
81	75	LEMAN	12	61	27	3	.
82	77	OMEGA	18	63	32	6	.
83	73	APOLL	18	80	26	4	.
84	76	STARF	20	.	.	.	M

AVERAGE	9.8	56.1	16.1	-7.0
COUNT	85	85	85	85
MAX	51	88	59	35
MIN	-50	0	-11	-90
STD	16.2	20.8	14.0	20.5
SUM	832	4773	1366	-593
VAR	262.1	433.0	195.5	419.5

APPENDIX F

DRIVER COMPARTMENT MEASUREMENTS: 1984-1985
VEHICLES

MAKE	MODEL	YR	VINNO	LOCATION	DATE	CYL	SEAT
AUDI	4000S	82	WAUFA081XCA046192	CONCORD	10/22/86	4	BUC
AUDI	4000S	84	WAUFA0817EA041826	CONCORD	10/15/86	4	BUC
AUDI	400S	83	WAUFA0811DA136056	CONCORD	11/12/86	5	BUC
AUDI	5000	84	WAUFB0444EN112406	CONCORD	10/20/86	5	BUC
AUDI	5000S	84	WAUFB0449ENO80617	.	12/15/86	5	BUC
AUDI	5000 TURBO	82	WAUGH0436CN065158	CONCORD	10/14/86	5	BUC
AUDI	5000 TURBO	86	WAUHDO449GNO69462	CONCORD	12/05/86	5	BUC
BUICK	RIVERA	85	IG4EZ5745FE400664	CONCORD	.	8	BUC
CADILLAC	COUPE DEVL	85	1G6CD4781F4203083	.	.	8	BEN
CADILLAC	ELDORADO	85	1G6EL6789FE609954	CONCORD	11/25/86	6	BUC
CADILLAC	FLEETWOOD	85	1G6CB6980F4252905	CONCORD	.	8	BUC
CHEVY	CAMARO	85	1G1FP87S5FN106508	CONCORD	11/26/86	6	BUC
CHEVY	CAMARO	85	1G1FP87S6FL457231	CONCORD	11/5/86	6	BUC
CHEVY	CAMARO	85	1G1FP8757FH118614	CONCORD	11/10/86	6	BUC
CHEVY	CAPRICE CLAS	85	1G1BN69Z7FH118614	CONCORD	10/21/86	6	BUC
CHEVY	CAVALIER	85	1G1JC69P9FJ212700	CONCORD	11/18/86	4	BUC
CHEVY	CAVALIER	85	1G1JD69P1FJ165188	CONCORD	11/12/86	5	BUC
CHEVY	CAVALIER	85	IGIJD35PIFJ129098	CONCORD	12/14/86	4	BUC
CHEVY	CAVALIER	85	1G1JB69P2FJ159870	CONCORD	11/18/86	4	BUC
CHEVY	CELEBRITY	85	IGIAWI9RXFG147557	CONCORD	.	4	BEN
CHEVY	CELEBRITY	85	IGIAW19R2FG138593	CONCORD	.	4	BEN
CHEVY	CELEBRITY	85	1G1AW19X7FG130780	CONCORD	11/5/86	6	BUC
CHEVY	CELEBRITY	85	1G1AW19R7F6120218	CONCORD	10/22/86	4	BUC
CHEVY	CELEBRITY	85	1G1AW19R7FG117893	CONCORD	11/18/86	4	BEN
CHEVY	MONTE CARLO	85	1G1GZ37Z0FR199560	CONCORD	11/12/86	6	BUC
CHEVY	MONTE CARLO	85	1G1GZ37Z4FR142178	CONCORD	12/2/86	6	BUC
CHEVY	MONTE CARLO	85	1G1G237G7FR170247	CONCORD	10/20/86	8	BUC
CHEVY	MONTE CARLO	85	1G1GZ37Z9FR142760	CONCORD	12/1/86	6	BUC
CHEVY	NOVA	85	1Y1SK19486Z109452	CONCORD	11/12/86	4	BUC
CHEVY	CAMARO	85	IGIFP8759FN132433	CONCORD	.	6	BUC
FORD	ESCORT	85	2FABP0941FB103158	CONCORD	11/10/86	4	BUC
FORD	ESCORT	85	IFABPI347FTJI5667	CONCORD	.		BUC
FORD	ESCORT	85	1FABP0422FR154061	CONCORD	11/10/86	4	BUC
FORD	LTD	85	1FAB393366140697	CONCORD	11/17/86	6	BUC
FORD	LTD	85	1FABP3937FG176570	CONCORD	11/3/86	6	BUC
FORD	LTD	85	1FABP3932GG137516	CONCORD	11/11/86	6	BUC
FORD	LTD	85	1FABP3934GG142608	CONCORD	11/11/86	6	BUC
FORD	MARK IV	85	1MRBP98FY742943	CONCORD	11/3/86	8	BUC
FORD	MARK IV	85	1MRBP98F2FY742943	CONCORD	11/4/86	8	BUC
FORD	MUSTANG	85	FABP2737GF278939	CONCORD	.	6	BUC
FORD	MUSTANG LX	85	1FABPZ6A26F178019	CONCORD	11/5/86	4	BUC
FORD	MUSTANG LX	85	IFABP28A3FF197805	CONCORD	10/21/86	4	BUC
FORD	TEMPO	85	1FABP22XXFK143583	CONCORD	10/27/86	4	BUC
FORD	TEMPO	85	1FABP23XXFK237798	CONCORD	11/4/86	4	BUC
FORD	TEMPO	85	2FABPZZX4FB211001	CONCORD	11/13/86	4	BUC
FORD	TEMPO	85	.	CONCORD	11/17/86	4	BUC
FORD	THUNDERBIRD	85	1FABP46F5FH197285	CONCORD	11/12/86	8	BUC
FORD	THUNDERBIRD	85	1FARP4637GH144417	CONCORD	10/27/86	6	BUC

MAKE	MODEL	YR	FUEL	BDYSTL	TIL	ODO	TRAN	PBRAK	PSTR
AUDI	4000S	82	INJ	4DR	N	80057	AUT	?	?
AUDI	4000S	84	INJ	4DR	N	59470	MAN	Y	Y
AUDI	400S	83	INJ	4DR	N	77202	AUT	.	.
AUDI	5000	84	INJ	4DR	N	68814	MAN	Y	Y
AUDI	5000S	84	INJ	4DR	N	55825	AUT	Y	Y
AUDI	5000 TURBO	82	INJ	4DR	N	84198	AUT	Y	Y
AUDI	5000 TURBO	86	INJ	4DR	N	11509	AUT	Y	Y
BUICK	RIVERA	85	CARB	2DR	Y	35569	AUT	Y	Y
CADILLAC	COUPE DEVILL	85	INJ	2DR	Y	36731	AUT	Y	Y
CADILLAC	ELDORADO	85	INJ	2DR	Y	26208	AUT	Y	Y
CADILLAC	FLEETWOOD	85	INJ	4DR	Y	35887	AUT	Y	Y
CHEVY	CAMARO	85	INJ	2DR	Y	13898	AUT	Y	Y
CHEVY	CAMARO	85	INJ	2DR	N	21197	AUT	Y	Y
CHEVY	CAMARO	85	INJ	2DR	N	21627	MAN	Y	Y
CHEVY	CAPRICE CLAS	85	INJ	4DR	Y	69265	AUT	Y	Y
CHEVY	CAVALIER	85	INJ	4DR	N	70279	AUT	Y	Y
CHEVY	CAVALIER	85	INJ	4DR	N	10326	AUT	Y	Y
CHEVY	CAVALIER	85	INJ	WAG	N	31604	AUT	Y	Y
CHEVY	CAVALIER	85	INJ	4DR	N	47755	AUT	Y	Y
CHEVY	CELEBRITY	85	INJ	4DR	Y	30697	AUT	Y	Y
CHEVY	CELEBRITY	85	INJ	4DR	N	45488	AUT	Y	Y
CHEVY	CELEBRITY	85	CARB	4DR	N	62230	AUT	Y	Y
CHEVY	CELEBRITY	85	INJ	4DR	Y	54776	AUT	Y	Y
CHEVY	CELEBRITY	85	INJ	4DR	N	37903	AUT	Y	Y
CHEVY	MONTE CARLO	85	INJ	2DR	Y	40253	AUT	Y	Y
CHEVY	MONTE CARLO	85	INJ	2DR	Y	41478	AUT	Y	Y
CHEVY	MONTE CARLO	85	CARB	2DR	Y	19448	AUT	Y	Y
CHEVY	MONTE CARLO	85	INJ	2DR	Y	38888	AUT	Y	Y
CHEVY	NOVA	85	CARB	4DR	N	5697	AUT	Y	Y
CHEVY	CAMARO	85	INJ	2DR	N	27095	AUT	Y	Y
FORD	ESCORT	85	CARB	WAG	N	43209	AUT	N	Y
FORD	ESCORT	85	INJ	4DR	.	37090	AUT	Y	Y
FORD	ESCORT	85	CARB	2DR	N	19187	MAN	N	Y
FORD	LTD	85	INJ	4DR	Y	37740	AUT	Y	Y
FORD	LTD	85	INJ	4DR	Y	20862	AUT	Y	Y
FORD	LTD	85	INJ	4DR	Y	29537	AUT	Y	Y
FORD	LTD	85	INJ	4DR	Y	35212	AUT	Y	Y
FORD	MARK IV	85	INJ	2DR	Y	32588	AUT	Y	Y
FORD	MARK IV	85	INJ	2DR	Y	36492	AUT	Y	Y
FORD	MUSTANG	85	INJ	2DR	Y	11643	AUT	Y	Y
FORD	MUSTANG LX	85	CARB	2DR	N	7907	MAN	Y	Y
FORD	MUSTANG LX	85	CARB	2DR	Y	27121	MAN	Y	Y
FORD	TEMPO	85	CARB	4DR	N	27526	AUT	Y	Y
FORD	TEMPO	85	CARB	4DR	Y	34544	AUT	N	Y
FORD	TEMPO	85	CARB	4DR	N	2927	AUT	Y	Y
FORD	TEMPO	85	INJ	2DR	N	20981	AUT	Y	Y
FORD	THUNDERBIRD	85	INJ	2DR	Y	9988	AUT	Y	Y
FORD	THUNDERBIRD	85	INJ	2DR	Y	21841	AUT	Y	Y

MAKE	MODEL	YR	AC	CRCON	SHIFT	PV	SWT
AUDI	4000S	82	N	N	CENCON	POOR	YES
AUDI	4000S	84	Y	?	CENCON	FAIR	YES
AUDI	400S	83	Y	N	CENCON	FAIR	N
AUDI	5000	84	Y	Y	CENCON	POOR	YES
AUDI	5000S	84	Y	Y	CENCON	GOOD	LEFT
AUDI	5000 TURBO	82	Y	Y	CENCON	POOR	YES
AUDI	5000 TURBO	86	Y	N	CENCON	POOR	LEFT, 1"
BUICK	RIVERA	85	Y	Y	STCOL	GOOD	N
CADILLAC	COUPE DEVILL	85	Y	Y	STCOL	FAIR	N
CADILLAC	ELDORADO	85	Y	Y	STCOL	GOOD	N
CADILLAC	FLEETWOOD	85	Y	Y	STCOL	GOOD	N
CHEVY	CAMARO	85	Y	N	CENCON	GOOD	N
CHEVY	CAMARO	85	Y	N	CENCON	FAIR	N
CHEVY	CAMARO	85	N	N	CENCON	FAIR	N
CHEVY	CAPRICE CLAS	85	Y	N	STCOL	GOOD	YES
CHEVY	CAVALIER	85	Y	N	CENCON	FAIR	LEFT, 26/32
CHEVY	CAVALIER	85	Y	N	CENCON	FAIR	N
CHEVY	CAVALIER	85	Y	N	CENCON	FAIR	LEFT 1+4/32
CHEVY	CAVALIER	85	Y	N	CENCON	FAIR	LEFT, 15/32
CHEVY	CELEBRITY	85	Y	N	STCOL	UNK	N
CHEVY	CELEBRITY	85	Y	N	STCOL	GOOD	LEFT 16/32
CHEVY	CELEBRITY	85	Y	N	STCOL	GOOD	N
CHEVY	CELEBRITY	85	Y	N	STCOL	GOOD	N
CHEVY	CELEBRITY	85	Y	N	STCOL	GOOD	N
CHEVY	MONTE CARLO	85	Y	N	STCOL	FAIR	N
CHEVY	MONTE CARLO	85	Y	Y	STCOL	GOOD	N
CHEVY	MONTE CARLO	85	Y	Y	CENCON	FAIR	N
CHEVY	MONTE CARLO	85	Y	Y	STCOL	EXCELLENT	LEFT 27/32
CHEVY	NOVA	85	N	N	CENCON	GOOD	N
CHEVY	CAMARO	85	Y	N	CENCON	GOOD	LEFT 18/32
FORD	ESCORT	85	N	N	CENCON	POOR	N
FORD	ESCORT	85	N	N	CENCON	POOR	LEFT 21/32
FORD	ESCORT	85	N	N	CENCON	FAIR	N
FORD	LTD	85	Y	Y	STCOL	GOOD	N
FORD	LTD	85	Y	Y	STCOL	GOOD	N
FORD	LTD	85	Y	Y	STCOL	GOOD	N
FORD	LTD	85	Y	Y	STCOL	GOOD	N
FORD	MARK IV	85	Y	Y	CENCON	FAIR	N
FORD	MARK IV	85	N	Y	CENCON	FAIR	N
FORD	MUSTANG	85	Y	Y	CENCON	GOOD	LEFT 29/32
FORD	MUSTANG LX	85	N	Y	CENCON	GOOD	N
FORD	MUSTANG LX	85	Y	Y	CENCON	FAIR	YES
FORD	TEMPO	85	Y	N	CENCON	POOR	YES
FORD	TEMPO	85	Y	Y	CENCON	POOR	N
FORD	TEMPO	85	Y	N	CENCON	FAIR	N
FORD	TEMPO	85	Y	N	CENCON	POOR	LEFT, 1+5/32
FORD	THUNDERBIRD	85	Y	Y	STCOL	GOOD	N
FORD	THUNDERBIRD	85	Y	Y	STCOL	FAIR	N

MAKE	MODEL	YR	SOF	C1T	C1M	C1B	E2	F3
AUDI	4000S	82	N	1.84	1.84	1.84	3.69	2.09
AUDI	4000S	84	N	1.84	1.84	1.84	4.19	2.59
AUDI	400S	83	N	1.81	1.81	1.81	3.09	2.09
AUDI	5000	84	N	2.00	2.00	2.00	3.62	3.00
AUDI	5000S	84	N	2.06	2.06	2.06	4.12	2.69
AUDI	5000 TURBO	82	N	2.00	2.03	1.28	3.25	2.56
AUDI	5000 TURBO	86	LEFT	2.00	2.12	2.00	4.00	2.66
BUICK	RIVERA	85	N	1.94	2.50	2.84	7.47	2.59
CADILLAC	COUPE DEVILL	85	N	1.81	2.06	2.22	5.00	2.06
CADILLAC	ELDORADO	85	N	2.00	2.50	2.87	7.50	2.56
CADILLAC	FLEETWOOD	85	N	1.87	2.12	2.25	4.97	2.00
CHEVY	CAMARO	85	N	1.37	1.97	1.37	5.34	2.34
CHEVY	CAMARO	85	N	2.00	1.94	1.56	5.37	2.37
CHEVY	CAMARO	85	N	1.66	1.94	1.53	5.31	2.41
CHEVY	CAPRICE CLAS	85	N	2.31	2.50	2.72	6.25	2.37
CHEVY	CAVALIER	85	N	1.78	2.00	2.12	4.88	2.37
CHEVY	CAVALIER	85	LEFT	1.78	1.97	2.12	4.94	1.87
CHEVY	CAVALIER	85	YES, TO LEFT	1.75	2.00	2.19	4.97	1.78
CHEVY	CAVALIER	85	LEFT	1.69	2.00	2.75	4.91	2.25
CHEVY	CELEBRITY	85	N	2.12	2.53	2.72	5.19	2.31
CHEVY	CELEBRITY	85	N	2.19	2.50	2.72	5.16	2.28
CHEVY	CELEBRITY	85	N	2.22	2.75	2.50	5.25	2.31
CHEVY	CELEBRITY	85	N	2.25	2.53	2.69	5.19	2.31
CHEVY	CELEBRITY	85	N	2.19	2.50	2.72	5.12	2.31
CHEVY	MONTE CARLO	85	N	1.62	1.97	2.12	5.25	2.37
CHEVY	MONTE CARLO	85	N	1.66	1.94	2.09	5.28	2.28
CHEVY	MONTE CARLO	85	N	1.72	1.91	2.16	5.31	2.47
CHEVY	MONTE CARLO	85	N	1.69	1.91	2.12	5.37	2.37
CHEVY	NOVA	85	N	1.16	1.72	1.16	3.75	2.06
CHEVY	CAMARO	85	N	1.59	1.94	1.56	5.37	2.37
FORD	ESCORT	85	LEFT	1.47	1.47	1.47	3.37	1.94
FORD	ESCORT	85	N	1.50	1.50	1.50	3.37	1.94
FORD	ESCORT	85	N	1.37	1.37	1.37	3.37	1.91
FORD	LTD	85	N	1.19	1.19	1.09	5.25	2.50
FORD	LTD	85	N	1.16	1.16	1.09	5.28	2.53
FORD	LTD	85	N	1.19	1.19	1.06	5.28	2.44
FORD	LTD	85	N	1.19	1.19	1.06	5.28	2.44
FORD	MARK IV	85	YES	1.75	1.75	1.75	5.28	2.62
FORD	MARK IV	85	N	1.75	1.75	1.75	5.34	2.47
FORD	MUSTANG	85	N	1.12	1.12	1.00	5.28	1.91
FORD	MUSTANG LX	85	N	1.22	1.09	1.22	5.28	2.00
FORD	MUSTANG LX	85	N	1.09	1.09	1.00	5.31	2.00
FORD	TEMPO	85	N	1.44	1.44	1.56	3.44	1.94
FORD	TEMPO	85	YES	1.47	1.47	1.50	3.41	1.91
FORD	TEMPO	85	YES	1.44	1.44	1.50	3.37	1.91
FORD	TEMPO	85	LEFT	1.47	1.47	1.50	3.44	1.91
FORD	THUNDERBIRD	85	N	1.19	1.19	1.06	5.37	2.50
FORD	THUNDERBIRD	85	N	1.16	1.16	1.00	5.22	2.59

MAKE	MODEL	YR	X4T	X4M	X4B	X5	X6	B7	X8	D1	D2
AUDI	4000S	82	3.16	3.16	3.00	6.75	4.62	1.72	19.00	1.94	1.75
AUDI	4000S	84	2.12	2.12	1.56	5.50	3.50	2.09	22.50	1.37	1.28
AUDI	400S	83	3.12	3.12	2.78	6.56	4.75	1.84	19.25	2.12	2.19
AUDI	5000	84	2.28	2.37	1.69	6.25	4.62	2.56	22.75	1.84	1.69
AUDI	5000S	84	3.87	3.87	2.87	6.25	4.12	2.19	20.00	2.12	2.00
AUDI	5000 TURBO	82	3.94			6.62	5.47	3.37	18.25	0.91	1.19
AUDI	5000 TURBO	86	3.81	3.94	2.87	6.00	4.34	2.56	19.50	2.44	2.19
BUICK	RIVERA	85	7.37	6.62	6.00	5.69	1.09	2.66	23.50	3.75	3.41
CADILLAC	COUPE DEVILL	85	5.28	5.09	4.62	6.22	2.94	2.50	22.50		
CADILLAC	ELDORADO	85	7.25	7.66	6.00	6.00	0.50	2.25	24.00	4.88	5.25
CADILLAC	FLEETWOOD	85	5.34	5.06	4.62	5.62	3.00	2.87	23.00		
CHEVY	CAMARO	85	5.75	5.41	4.81	4.50	2.37	2.25	20.25	3.37	1.62
CHEVY	CAMARO	85	5.75	5.44	5.00	5.25	2.22	2.50	20.00	2.72	1.31
CHEVY	CAMARO	85	3.47	3.09	2.50	4.88	2.16	2.81	20.00	2.53	1.75
CHEVY	CAPRICE CLAS	85	5.75	5.44	5.00	6.50	2.78	3.00	22.50	2.56	2.50
CHEVY	CAVALIER	85	4.34	4.00	3.59	5.56	3.00	2.37	21.25		
CHEVY	CAVALIER	85	3.87	3.75	3.31	6.00	3.00	2.75	22.00		
CHEVY	CAVALIER	85	3.75	3.47	3.12	5.50	2.87	2.62	22.00		
CHEVY	CAVALIER	85	4.34	4.06	3.97	5.37	3.00	1.78	22.00		
CHEVY	CELEBRITY	85	5.62	5.34	4.97	6.37	4.25	2.53	23.00		
CHEVY	CELEBRITY	85	5.69	5.37	4.91	6.00	3.56	2.84	23.00		
CHEVY	CELEBRITY	85	5.66	4.91	5.31	6.00	3.25	2.44	22.00		
CHEVY	CELEBRITY	85	5.78	5.37	4.97	5.91	4.00	2.81	22.00		
CHEVY	CELEBRITY	85	5.75	5.41	4.94	6.12	3.75	2.62	22.50		
CHEVY	MONTE CARLO	85	4.34	4.12	3.50	6.44	2.37	2.25	19.00	2.37	2.25
CHEVY	MONTE CARLO	85	4.31	4.03	3.53	5.94	2.09	1.75	18.25	2.19	2.12
CHEVY	MONTE CARLO	85	4.37	4.09	3.66	6.50	2.41	2.12	18.75	2.00	2.19
CHEVY	MONTE CARLO	85	4.28	4.00	3.62	6.00	1.87	1.66	18.75	2.75	2.41
CHEVY	NOVA	85	3.75	4.03	3.62	5.72	3.37	2.37	20.50	2.41	2.34
CHEVY	CAMARO	85	5.72	5.41	5.00	5.00	2.62	1.81	20.00	2.41	1.62
FORD	ESCORT	85	3.50	3.22	2.78	6.75	4.06	3.62	20.50		
FORD	ESCORT	85	3.47	3.19	2.66	6.62	4.03	3.12	21.50		
FORD	ESCORT	85	2.25	2.16	1.66	6.37	3.94	3.72	20.75		
FORD	LTD	85	3.94	3.66	3.00	5.00	2.25	2.91	18.00	0.91	1.53
FORD	LTD	85	4.00	3.66	3.25	5.31	2.37	3.72	18.25	1.09	1.16
FORD	LTD	85	3.91	3.72	3.00	5.53	2.28	3.34	17.50	1.12	1.31
FORD	LTD	85	4.00	3.75	3.00	5.12	2.25	2.78	17.75	1.09	1.62
FORD	MARK IV	85	4.03	3.72	3.16	5.00	1.91	2.69	16.75	1.03	1.22
FORD	MARK IV	85	4.06	3.72	3.00	4.75	2.12	2.59	16.75	0.84	1.00
FORD	MUSTANG	85	3.25	2.94	2.37	5.37	2.62	3.25	18.00	1.28	1.75
FORD	MUSTANG LX	85	2.28	1.91	2.19	5.66	2.37	2.75	18.00	1.25	1.78
FORD	MUSTANG LX	85	2.31	2.19	1.94	5.31	2.31	2.87	17.75	0.94	1.62
FORD	TEMPO	85	3.47	3.16	2.62	6.00	3.78	3.75	20.25		
FORD	TEMPO	85	3.41	3.25	2.75	5.72	3.69	3.28	18.75		
FORD	TEMPO	85	3.47	3.19	2.62	5.62	3.94	3.00	20.00		
FORD	TEMPO	85	3.37	3.25	2.50	5.87	3.75	3.16	20.00		
FORD	THUNDERBIRD	85	4.00	3.72	3.00	5.12	1.94	2.94	18.25	1.34	1.25
FORD	THUNDERBIRD	85	4.03	3.69	3.00	5.09	2.25	2.81	18.00	1.16	0.91

MAKE	MODEL	YR	D3	X12	A13	X14	X15	X16	G1
AUDI	4000S	82	1.56	0.69	0.12	10.19	22.75	.	2.00
AUDI	4000S	84	0.94	0.37	2.81	10.41	23.25	.	2.25
AUDI	400S	83	1.94	1.37	0.62	10.37	23.00	.	2.00
AUDI	5000	84	1.66	1.34	2.87	12.00	22.00	.	1.53
AUDI	5000S	84	1.50	1.37	0.00	11.00	23.66	.	2.25
AUDI	5000 TURBO	82	1.19	0.19	0.62	10.28	23.00	.	2.06
AUDI	5000 TURBO	86	1.34	1.34	1.34	10.44	23.75	.	1.59
BUICK	RIVERA	85	2.16	0.62	2.50	12.06	25.50	.	2.87
CADILLAC	COUPE DEVILL	85		0.19	2.50	9.37	25.94	.	3.41
CADILLAC	ELDORADO	85	2.75	0.59	3.00	11.19	25.25	.	2.87
CADILLAC	FLEETWOOD	85		0.00	2.53	9.00	26.25	.	3.00
CHEVY	CAMARO	85	1.62	0.12	0.12	9.47	26.69	.	2.69
CHEVY	CAMARO	85	1.12	0.16	1.87	9.00	26.00	.	2.50
CHEVY	CAMARO	85	1.62	0.25	0.94	8.47	25.75	.	2.25
CHEVY	CAPRICE CLAS	85	2.25	2.91	2.00	11.31	20.00	.	2.87
CHEVY	CAVALIER	85		1.47	2.47	11.62	24.25	.	3.47
CHEVY	CAVALIER	85		1.12	1.50	11.56	24.25	.	2.56
CHEVY	CAVALIER	85		1.31	3.50	11.62	24.44	.	2.12
CHEVY	CAVALIER	85		1.25	2.81	10.66	24.75	.	2.91
CHEVY	CELEBRITY	85		0.87	3.75	11.06	25.50	.	2.37
CHEVY	CELEBRITY	85		0.75	3.50	10.50	25.12	.	2.87
CHEVY	CELEBRITY	85	2.87	0.37	5.16	10.78	26.37	.	2.75
CHEVY	CELEBRITY	85		0.00	3.78	11.59	27.25	.	2.28
CHEVY	CELEBRITY	85		0.25	4.72	11.25	24.69	.	2.12
CHEVY	MONTE CARLO	85	1.87	0.00	1.25	11.50	26.87	.	2.81
CHEVY	MONTE CARLO	85	2.19	0.19	0.19	10.53	26.25	.	3.25
CHEVY	MONTE CARLO	85	1.94	1.00	0.69	12.00	26.25	.	3.00
CHEVY	MONTE CARLO	85	2.03	0.75	0.75	10.12	26.56	.	3.06
CHEVY	NOVA	85	2.37	0.37	4.25	12.62	23.50	.	1.87
CHEVY	CAMARO	85	1.53	0.78	1.00	7.87	26.94	.	2.25
FORD	ESCORT	85		0.22	2.22	10.75	24.50	.	3.00
FORD	ESCORT	85		0.62	2.12	10.78	24.75	.	2.81
FORD	ESCORT	85		0.19	3.97	10.50	25.00	.	4.62
FORD	LTD	85	1.62	0.87	1.03	10.00	25.75	.	2.91
FORD	LTD	85	1.19	1.03	0.25	9.75	25.12	.	2.50
FORD	LTD	85	1.59	0.81	0.31	10.00	27.75	.	3.00
FORD	LTD	85	1.62	0.91	0.87	9.62	24.75	.	2.62
FORD	MARK IV	85	1.22	0.75	2.47	10.00	25.25	.	4.12
FORD	MARK IV	85	1.09	0.41	0.09	10.44	25.87	.	3.22
FORD	MUSTANG	85	1.69	0.62	0.75	10.44	25.87	.	2.66
FORD	MUSTANG LX	85	1.69	0.75	0.75	10.75	25.75	.	3.00
FORD	MUSTANG LX	85	1.53	0.56	1.28	10.00	23.25	.	2.66
FORD	TEMPO	85		0.28	2.91	23.84	11.37	.	3.00
FORD	TEMPO	85	2.91	0.19	2.84	10.87	25.34	.	2.81
FORD	TEMPO	85		0.12	3.50	11.87	24.47	.	2.12
FORD	TEMPO	85		0.50	4.12	11.87	24.62	.	2.59
FORD	THUNDERBIRD	85	1.25	1.12	0.25	10.50	25.81	.	2.22
FORD	THUNDERBIRD	85	0.81	0.59	2.22	26.37	11.19	.	3.16

MAKE	MODEL	YR	G2	G3
AUDI	4000S	82	0.44	1.41 Y
AUDI	4000S	84	0.56	2.59 Y
AUDI	400S	83	1.25	2.19 Y
AUDI	5000	84	1.03	2.12 Y
AUDI	5000S	84	0.66	1.87 Y
AUDI	5000 TURBO	82	1.16	2.31 Y
AUDI	5000 TURBO	86	0.72	1.84 .
BUICK	RIVERA	85	1.50	2.78 Y
CADILLAC	COUPE DEVILL	85	1.69	2.66 Y
CADILLAC	ELDORADO	85	2.00	2.87 Y
CADILLAC	FLEETWOOD	85	1.59	1.94 Y
CHEVY	CAMARO	85	0.62	2.09 Y
CHEVY	CAMARO	85	1.00	2.09 Y
CHEVY	CAMARO	85	0.75	2.50 Y
CHEVY	CAPRICE CLAS	85	0.34	1.03 Y
CHEVY	CAVALIER	85	1.69	2.62 Y
CHEVY	CAVALIER	85	1.53	2.34 Y
CHEVY	CAVALIER	85	1.87	2.87 Y
CHEVY	CAVALIER	85	1.87	2.75 Y
CHEVY	CELEBRITY	85	1.91	2.94 Y
CHEVY	CELEBRITY	85	1.62	2.69 Y
CHEVY	CELEBRITY	85	1.62	2.91 Y
CHEVY	CELEBRITY	85	0.25	1.06 Y
CHEVY	CELEBRITY	85	1.56	3.00 Y
CHEVY	MONTE CARLO	85	1.12	2.25 Y
CHEVY	MONTE CARLO	85	1.37	2.31 Y
CHEVY	MONTE CARLO	85	1.59	2.25 .
CHEVY	MONTE CARLO	85	1.37	2.37 Y
CHEVY	NOVA	85	1.37	2.00 .
CHEVY	CAMARO	85	0.75	0.75 Y
FORD	ESCORT	85	1.56	2.37 Y
FORD	ESCORT	85	1.37	2.12 Y
FORD	ESCORT	85	1.37	2.12 Y
FORD	LTD	85	1.00	1.91 Y
FORD	LTD	85	1.12	2.50 Y
FORD	LTD	85	1.31	2.12 Y
FORD	LTD	85	1.00	2.25 Y
FORD	MARK IV	85	0.91	1.81 Y
FORD	MARK IV	85	0.94	1.78 Y
FORD	MUSTANG	85	1.12	2.12 Y
FORD	MUSTANG LX	85	1.00	1.62 Y
FORD	MUSTANG LX	85	1.25	1.91 Y
FORD	TEMPO	85	0.62	1.25 Y
FORD	TEMPO	85	1.28	2.31 Y
FORD	TEMPO	85	1.00	1.87 Y
FORD	TEMPO	85	1.00	1.81 Y
FORD	THUNDERBIRD	85	0.87	2.12 Y
FORD	THUNDERBIRD	85	1.06	2.53 Y

MAKE	MODEL	YR	VINNO	LOCATION	DATE	CYL	SEAT
LINCOLN	CONTINENTAL	85	1MRBP97F2F4743706	CONCORD	11/3/86	8	BUC
LINCOLN	CONTINENTAL	85	1MRBP97F3F4743715	CONCORD	10/27/86		BUC
NISSAN	300ZX		JNIHZ1453FX088040	CONCORD	.	6	BUC
NISSAN	300ZX	85	JNIHZ1655FX042013	CONCORD	10/15/86	6	BUC
NISSAN	300ZX TURBO	85	JNICZ1453FX064329	CONCORD	12/16/86	6	BUC
NISSAN	MAXIMA	85	JNIHUIIS2FT006485	CONCORD	11/24/86	6	BUC
OLDS	98	85	1G3CW6938F4310573	CONCORD	11/26/86	6	BUC
OLDS	98	85	1G3CW6931F4314978	CONCORD	11/26/86	6	BUC
OLDS	98	85	1G3CW693XF4325963	CONCORD	11/5/86	6	BUC
OLDS	98	85	1G3CW693XF4325963	CONCORD	.	6	BUC
OLDS	CUTLASS SUP.	85	1G3GR69A7FR388125	CONCORD	12/1/86	6	BEN
OLDS	CUTLAS SUPRE	85	2636M47AIF2326194	CONCORD	12/16/86	6	BUC
PONTIAC	FIERO	85	162PF3793FP230588	CONCORD	11/25/86	6	BUC
PONTIAC	FIERO	85	.	CONCORD	11/10/86	6	BUC
PONTIAC	FIERO	85	1G2PM37R4FP247387	CONCORD	.	4	BUC
TOYOTA	CELICA ST	85	JT2RA63C7F6236995	CONCORD	10/14/86	4	BUC

MAKE	MODEL	YR	FUEL	BDYSTL	TIL	ODO	TRAN	PBRAK	PSTR
LINCOLN	CONTINENTAL	85	INJ	4DR	Y	34924	AUT	Y	Y
LINCOLN	CONTINENTAL	85	INJ	4DR	Y		AUT	Y	Y
NISSAN	300ZX		INJ	2DR	N	23848	MAN	Y	Y
NISSAN	300ZX	85	INJ	2DR	Y	16515	AUT	Y	Y
NISSAN	300ZX TURBO	85	INJ	2DR	Y	17522	AUT	Y	Y
NISSAN	MAXIMA	85	INJ	4DR	Y	26959	AUT	Y	Y
OLDS	98	85	INJ	4DR	Y	39318	AUT	Y	Y
OLDS	98	85	INJ	4DR	Y	33727	AUT	.	Y
OLDS	98	85	INJ	4DR	Y	67018	AUT	Y	Y
OLDS	98	85	INJ	4DR	Y	67018	AUT	Y	Y
OLDS	CUTLASS SUP.	85	CARB	4DR	N	37449	AUT	Y	Y
OLDS	CUTLAS SUPRE	85	CARB	2DR	Y	24511	AUT	Y	Y
PONTIAC	FIERO	85	INJ	2DR	Y	26169	AUT	Y	N
PONTIAC	FIERO	85	INJ	2DR	Y	11521	MAN	Y	N
PONTIAC	FIERO	85	INJ	2DR	N	18188	MAN	Y	N
TOYOTA	CELICA ST	85	INJ	2DR	N	25015	MAN	Y	Y

MAKE	MODEL	YR	AC	CRCON	SHIFT	PV	SWT
LINCOLN	CONTINENTAL	85	N	Y	STCOL	FAIR	N
LINCOLN	CONTINENTAL	85	Y	Y	STCOL	FAIR	YES
NISSAN	300ZX		Y	Y	CENCON	FAIR	LEFT 21/32
NISSAN	300ZX	85	Y	Y	CENCON	POOR	N
NISSAN	300ZX TURBO	85	Y	Y	CENCON	GOOD	N
NISSAN	MAXIMA	85	Y	Y	CENCON	GOOD	LEFT 27/32
OLDS	98	85	Y	Y	STCOL	GOOD	N
OLDS	98	85	Y	Y	STCOL	GOOD	N
OLDS	98	85	Y	Y	STCOL	FAIR	N
OLDS	98	85	Y	Y	STCOL	FAIR	N
OLDS	CUTLASS SUP.	85	Y	N	STCOL	GOOD	LEFT 8/32
OLDS	CUTLAS SUPRE	85	Y	Y	STCOL	GOOD	N
PONTIAC	FIERO	85	N	N	CENCON	POOR	LEFT 30/32
PONTIAC	FIERO	85	Y	Y	CENCON	FAIR	N
PONTIAC	FIERO	85	N	N	CENCON	FAIR	N
TOYOTA	CELICA ST	85	Y	N	CENCON	FAIR	N

MAKE	MODEL	YR	SOF	C1T	C1M	C1B	E2	F3
LINCOLN	CONTINENTAL	85	N	1.72	1.72	1.72	5.34	2.59
LINCOLN	CONTINENTAL	85	YES	1.75	1.75	1.75	5.22	2.59
NISSAN	300ZX		YES, TO LEFT	1.87	1.97	1.91	5.84	2.16
NISSAN	300ZX	85	N	1.94	1.94	1.94	5.91	2.31
NISSAN	300ZX TURBO	85	N	1.91	1.94	1.87	5.91	2.25
NISSAN	MAXIMA	85	YES	1.37	2.22	1.87	5.91	2.31
OLDS	98	85	N	1.81	2.09	2.22	4.91	2.00
OLDS	98	85	N	1.81	2.09	2.25	4.88	2.00
OLDS	98	85	N	1.81	2.03	2.22	5.03	2.06
OLDS	98	85	N	1.78	2.09	2.22	5.00	2.00
OLDS	CUTLASS SUP.	85	N	1.69	2.00	2.09	5.28	2.34
OLDS	CUTLAS SUPRE	85	N	1.62	1.91	2.09	5.34	2.37
PONTIAC	FIERO	85	YES, TO RIGHT	1.94	2.12	2.28	4.94	2.37
PONTIAC	FIERO	85	RIGHT	1.94	2.12	2.25	5.00	2.25
PONTIAC	FIERO	85	RIGHT	1.91	2.12	2.25	4.88	2.34
TOYOTA	CELICA ST	85	N	1.72	1.72	1.72	4.25	2.41

MAKE	MODEL	YR	X4T	X4M	X4B	X5	X6	B7	X8	D1	D2
LINCOLN	CONTINENTAL	85	4.06	3.78	3.00	4.75	1.75	2.37	17.25	0.81	0.94
LINCOLN	CONTINENTAL	85	4.09	3.75	3.22	4.81	1.69	2.75	17.25	1.00	1.25
NISSAN	300ZX		2.66	2.56	1.87	6.00	3.47	1.87	18.75	1.78	1.66
NISSAN	300ZX	85	4.41	4.06	3.41	6.31	2.25	2.62	18.25	1.34	1.56
NISSAN	300ZX TURBO	85	4.44	4.00	3.25	6.12	3.56	2.62	18.50	1.87	2.00
NISSAN	MAXIMA	85	5.62	4.88	5.56	5.62	4.19	2.12	20.50	1.59	1.59
OLDS	98	85	5.28	5.06	4.62	6.87	2.75	2.50	23.00		
OLDS	98	85	5.28	5.09	4.62	6.81	3.34	2.78	23.00		
OLDS	98	85	5.28	5.09	4.72	6.00	4.16	2.94	23.00		
OLDS	98	85	5.34	5.09	4.59	6.34	4.00	2.66	23.25		
OLDS	CUTLASS SUP.	85	4.31	4.09	3.72	6.00	2.81	2.19	19.25	1.81	2.00
OLDS	CUTLAS SUPRE	85	4.34	4.09	3.50	6.34	2.25	2.31	18.50	2.19	1.75
PONTIAC	FIERO	85	4.25	4.00	3.94	5.50	3.25	3.12	22.50	1.37	0.75
PONTIAC	FIERO	85	2.37	2.12	1.72	5.75	3.50	2.12	15.50	1.53	1.06
PONTIAC	FIERO	85	2.37	2.09	1.62	5.47	3.28	2.19	22.75	1.50	0.91
TOYOTA	CELICA ST	85	2.25	2.16	1.69	5.81	3.72	2.62	18.25	2.53	1.53

MAKE	MODEL	YR	D3	X12	A13	X14	X15	X16	G1
LINCOLN	CONTINENTAL	85	0.62	0.75	0.41	10.81	25.75	.	3.50
LINCOLN	CONTINENTAL	85	1.25	1.72	0.81	24.75	11.94	.	3.59
NISSAN	300ZX		1.00	0.00	1.87	10.25	25.00	.	1.62
NISSAN	300ZX	85	1.28	0.00	0.00	9.87	23.50	.	1.81
NISSAN	300ZX TURBO	85	1.66	0.00	0.00	10.19	25.12	BULGE	2.03
NISSAN	MAXIMA	85	1.59	0.25	4.84	9.25	23.00	.	1.91
OLDS	98	85		0.56	3.50	10.50	26.00	.	3.00
OLDS	98	85		0.56	3.25	10.41	25.50	.	2.75
OLDS	98	85		0.37	3.00	9.87	24.75	.	2.25
OLDS	98	85		0.62	2.81	10.06	24.72	.	2.25
OLDS	CUTLASS SUP.	85	2.03	0.44	0.66	10.25	25.87	.	2.75
OLDS	CUTLAS SUPRE	85	1.62	1.12	0.62	9.91	26.50	.	2.75
PONTIAC	FIERO	85	0.84	0.00	6.50	7.31	0.00	BULGE	1.37
PONTIAC	FIERO	85	1.12	0.34	6.25	8.00	25.50	BULGE	1.84
PONTIAC	FIERO	85	0.84	0.00	6.50	7.50	25.25	BULGE	2.00
TOYOTA	CELICA ST	85	1.16	0.25	2.34	8.87	24.72	.	2.28

MAKE	MODEL	YR	G2	G3	
LINCOLN	CONTINENTAL	85	0.87	2.00	Y
LINCOLN	CONTINENTAL	85	1.12	2.12	N
NISSAN	300ZX		0.50	1.25	Y
NISSAN	300ZX	85	0.94	1.91	Y
NISSAN	300ZX_TURBO	85	0.62	2.62	Y
NISSAN	MAXIMA	85	1.25	2.00	Y
OLDS	98	85	1.75	2.62	Y
OLDS	98	85	1.59	2.72	Y
OLDS	98	85	1.62	2.50	Y
OLDS	98	85	1.47	2.37	Y
OLDS	CUTLASS_SUP.	85	1.87	2.50	Y
OLDS	CUTLAS_SUPRE	85	1.25	2.25	Y
PONTIAC	FIERO	85	1.37	2.25	Y
PONTIAC	FIERO	85	1.19	1.78	Y
PONTIAC	FIERO	85	1.50	2.06	Y
TOYOTA	CELICA_ST	85	1.00	1.81	Y

REFERENCES

1. Bentley, R. Audi 5000's Official Factory Repair Manual 1984, 1985, Robert Bentley, Inc. Cambridge, Mass., 1985
2. Audi 5000's Official Factory Repair Manual 1977- 1983, Robert Bentley, Inc., Cambridge, Mass., 1983
3. Chapanis, A., J.S. Cook III, M.W. Lund, and C.T. Morgan. Human Engineering guide to Equipment Design, McGraw-Hill, New York, NY, 1963.
4. Volkswagen of America. CIS-Electronic Fuel Injection, 2d ed., Audi of America Service Training, (Volkswagen of America Service Publications, Troy MI) #wsp 521-142-00 undated.
5. Hoxie, P. "Assessment Of Driver Inexperience With An Automobile As a Factor Which Contributes To Highway Accidents," DOT-HIS-806-593, December 1984.
6. Perel, M. "Vehicle Familiarity and Safety" DOT-HIS-806-509, July 1983
7. Rogers, S.B., W.W. Wierwille,, "The Occurrence of Accelerator and Brake Pedal Actuation Errors During Simulated Driving," Vehicle Analysis and Simulation Laboratory, Virginia Polytechnic Institute and State University, 1988
8. SAE Recommended Practice J1100,. Motor Vehicle Dimensions, Motor Vehicle Dimensions, SAE Recommended Practice J1100, Revised June 1984. Society of Automotive Engineers Handbook, 1986.
9. SAE Recommended Practice J826b, Devices for Use in Defining and Measuring Vehicle Seating Accomodations, SAE Standard J826, Revised April 1980. Society of Automotive Engineers Handbook, 1986.
10. Taylor, C.F. 1966. The Internal Combustion Engine in Theory and Practice, Vol. I Massachusetts Institute of Technology Press, Cambridge, Mass., 1966.