



CIS-Electronic Fuel Injection



**We Encourage Professionalism
Through Mechanic Certification**

Corporate Service Division

Index	1
Basic System Operation	2
Mixture Control Unit	3
Differential Pressure Regulator	8
Fuel Supply Diagram	10
Fuel Pump	11
Accumulator	12
Fuel Filters	13
Pressure Regulator	14
Cold Starting	16
Cold Running Controls	19
Electronic Control Unit	22
Sensor Plate Potentiometer	22
Temperature Sensor	23
After Start Enrichment	24
Warm-Up Enrichment	24
Acceleration Enrichment	24
Oxygen Sensor	25
Altitude Compensation	28
Full Throttle Enrichment	29
Deceleration Fuel Shut-Off	29

Test Procedures

Basic Checks and Adjustments	32
Pressure Testing	37
System Operational Checks	40
Sensor Plate Checking, Adjusting	44
Potentiometer Checking, Adjusting	48
Cold Start Valve/Thermo-time Switch Checking	50
Auxiliary Air Regulator Checking	51
Throttle Valve Position Checking	52
Fuel Pump Delivery	53
Injector Bench Testing	53
Injector Quality Testing	54
Idle Air Stabilization Valve Checking	56
Electrical Testing	57
Functional Diagrams	60
Glossary	63

All rights reserved. All information contained in this publication is based on the latest product information available at the time of printing. The right is reserved to make changes at any time without notice. No part of this publication may be reproduced, stored in a retrieval system, or transmitted in any form or by any means, electronic, mechanical, photocopying, recording, or otherwise, without the prior written permission of the publisher. This includes text, figures and tables. This information is simultaneously published in Canada. All rights reserved under Bern and Pan-American Copyright Conventions.

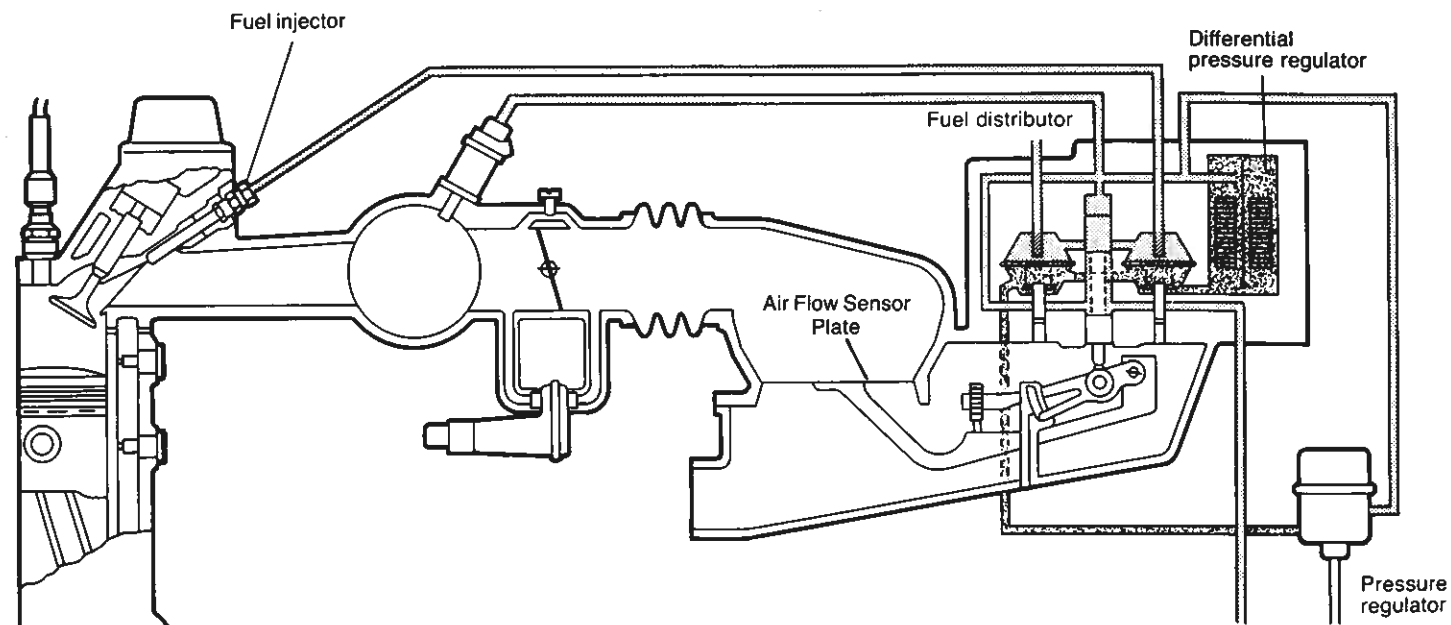

CIS electronic is a further development of the familiar CIS system and shares many of the same basic principles of operation. The following changes have been made to further refine the system:

- Elimination of the frequency valve and control pressure regulator. These two components have been replaced by a differential pressure regulator (electro-hydraulic actuator) which is attached to the fuel distributor and operated by an electronic control unit.
- A separate fuel pressure regulator to govern system pressure. This resulted in a redesigned fuel distributor and elimination of the pressure relief valve in the fuel distributor.
- A single electronic control unit that incorporates all the fuel system functions and includes the oxygen sensor system.
- Expanded functions of the fuel system which, on many cars, include:
 - Starting enrichment
 - After-start enrichment
 - Warm-up enrichment
 - Acceleration enrichment
 - Full load enrichment
 - Altitude correction
 - Deceleration fuel shut-off

MIXTURE CONTROL UNIT

The mixture control unit is located between the air cleaner and the throttle valve. It consists of the air sensor and the fuel distributor.

The air sensor measures the amount of air entering the engine and controls the amount of fuel injected by moving the control plunger in the fuel distributor.

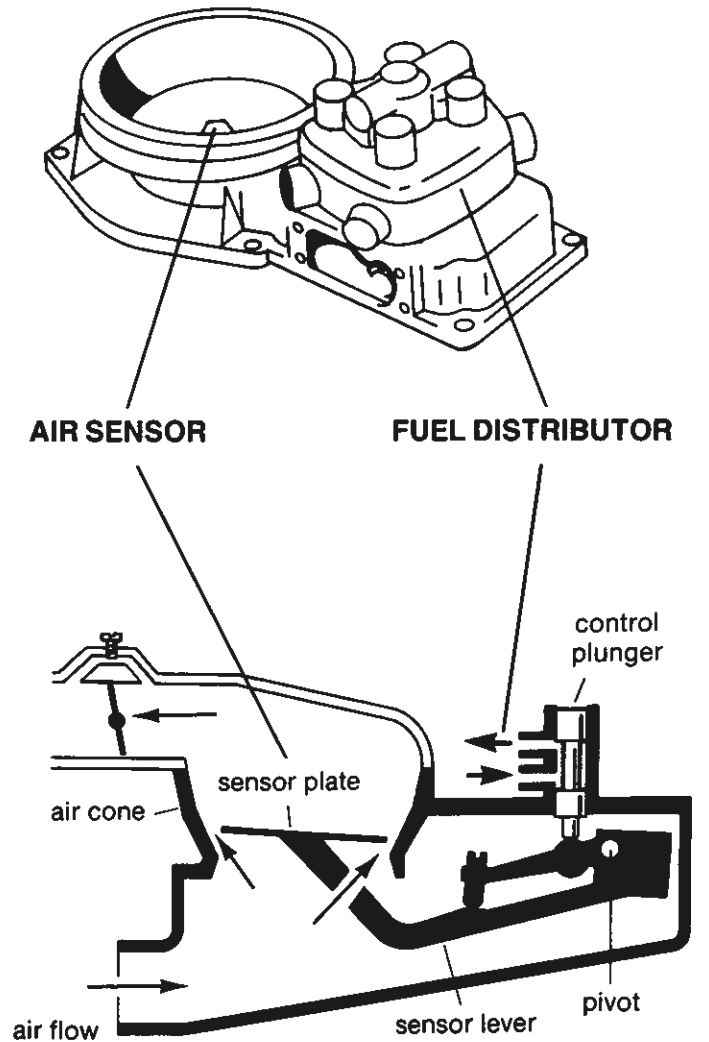

The flow of intake air through the air cone will lift the sensor plate causing the sensor lever to lift the control plunger in the fuel distributor.

As the control plunger rises, it allows more fuel to be delivered to the injectors.

Since the air sensor is constantly measuring the intake air and controlling the amount of fuel by raising or lowering the control plunger, the basic air/fuel mixture is always correct.

The pictures below show the relationship between air flow and fuel flow:

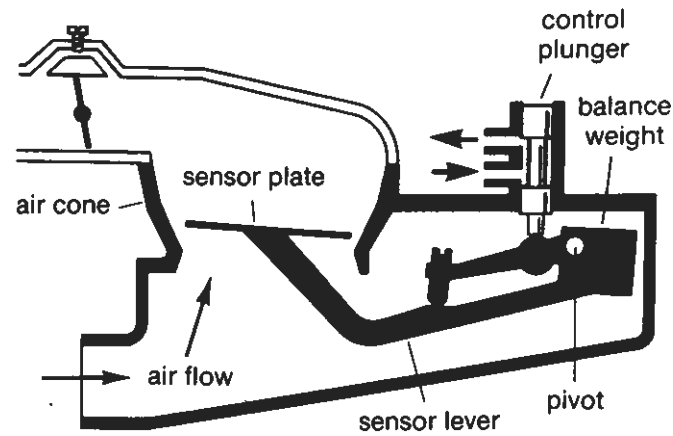

The operation of the air sensor is based on the "floating body principle" which says that a floating body suspended in a cone moves in a straight line according to the rate of air flow through the cone.

The CIS electronic "floating body" is the circular sensor plate bolted to the sensor lever which moves freely around a pivot point. The movement of the sensor plate, lever and control plunger are controlled and dampened by a balance weight at the end of the lever and system pressure acting on the top of the control plunger.

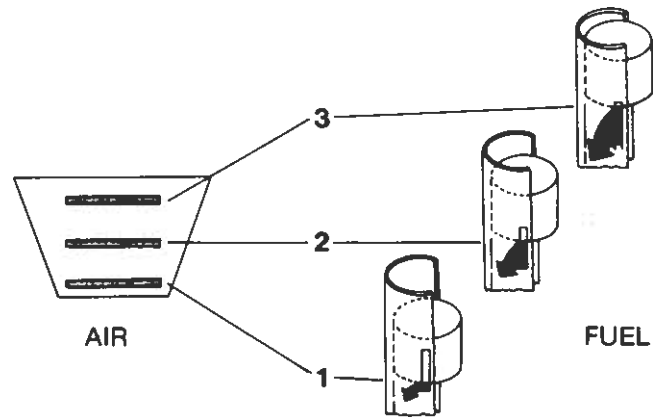

At (1), the slight air flow at idle lifts the sensor plate enough to raise the control plunger slightly. The metering slit in the fuel distributor is opened to allow enough fuel for idle.

As air flow increases, more of the metering slit is exposed (2) until at full throttle (3), the fuel flow is at maximum.

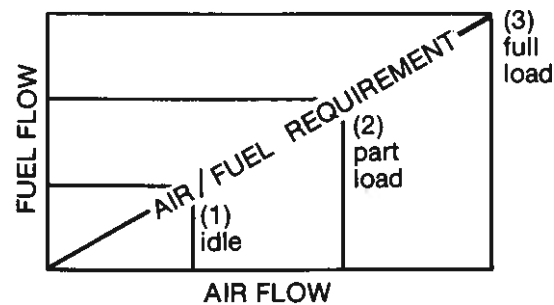

The graph represents an engine's basic air-fuel requirement.

Notice that with CIS electronic fuel injection the fuel flow is automatically corrected for any volume of air flow from idle throughout the full load range.

The sensor plate position has been changed because of the new fuel distributor. The control plunger now seats on an O-ring. There is now a small gap between the sensor lever and the control plunger when the sensor lever is at rest position. This is necessary to insure that the plunger seals completely against the O-ring when the engine is shut off. This results in the sensor plate resting below the edge of the sensor housing. When the engine is not running, the sensor plate and lever rest on a spring loaded stop.

The control plunger sits low enough to uncover the top edge of the metering slits. This allows residual system pressure to work directly on the injectors to eliminate fuel vaporization.

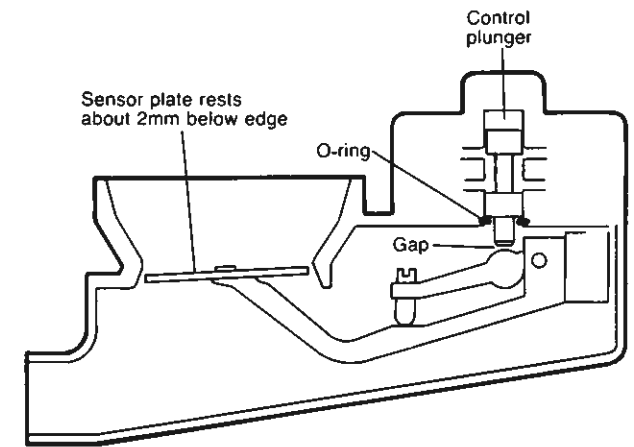

Should a backfire occur in the intake manifold, the sensor plate will be forced down against the spring loaded stop. This creates a larger opening around the sensor plate to reduce pressure and to prevent damage to the air sensor assembly.

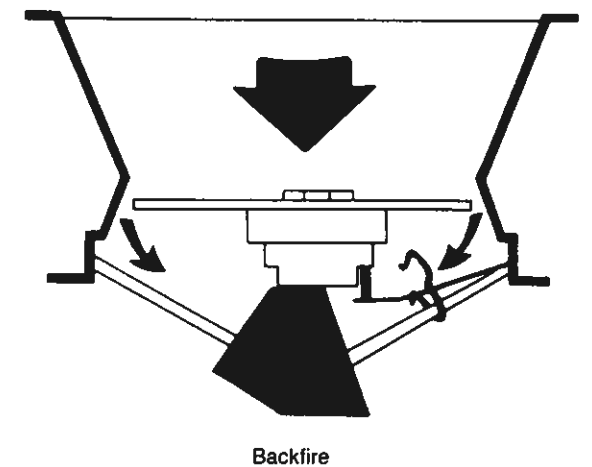

FUEL INJECTORS

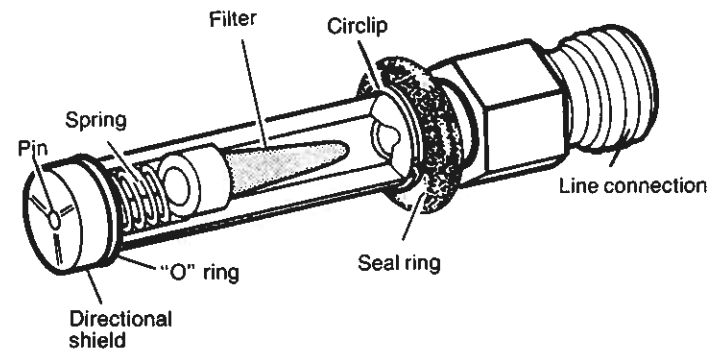

CIS injectors open at a pre-set pressure and spray atomized fuel continuously into the intake port near each intake valve.

When the engine is stopped, the fuel pressure is reduced and the pin and spring assembly at the end of the injector closes. This traps fuel under pressure in the system to prevent vapor lock and to insure quick hot starting.

All engines are now equipped with air shrouded injectors. Air flows through a passage in the cylinder head, through the injector insert and exits near the tip of the injector. The fuel leaving the injector is better atomized, reducing fuel condensation in the intake manifold.

There is now a second generation of air shrouded injectors. The changes consist of: A circlip added to the injector to hold the sealing "O" ring in position; a new brass injector insert; a separate plastic injector shroud; and a fluted air directional shield attached to the end of the injector to improve air flow around the injector nozzle. These changes enhance the fuel atomization and provide even smoother engine performance.

The new style 2 piece insert assembly must only be used together with the new injectors that have the directional shield attached to the nozzle. This complete assembly may be installed in earlier vehicles with air shrouded injectors.

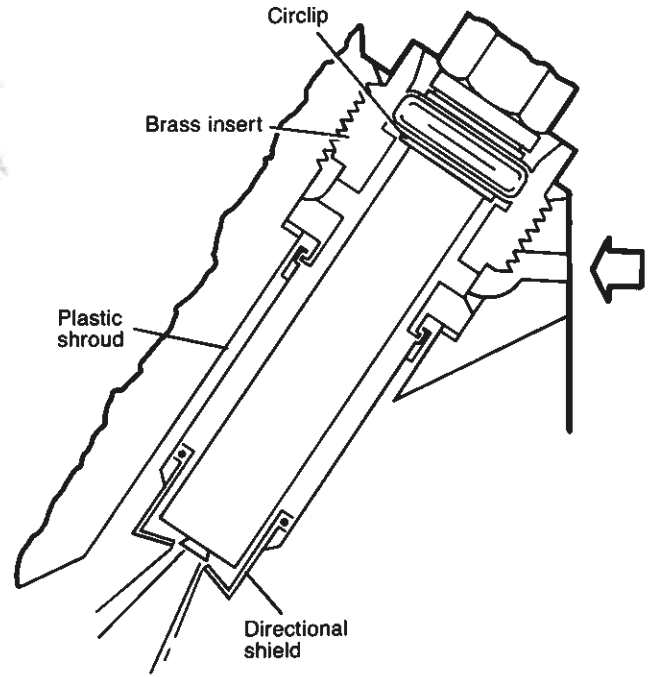

FUEL DISTRIBUTOR

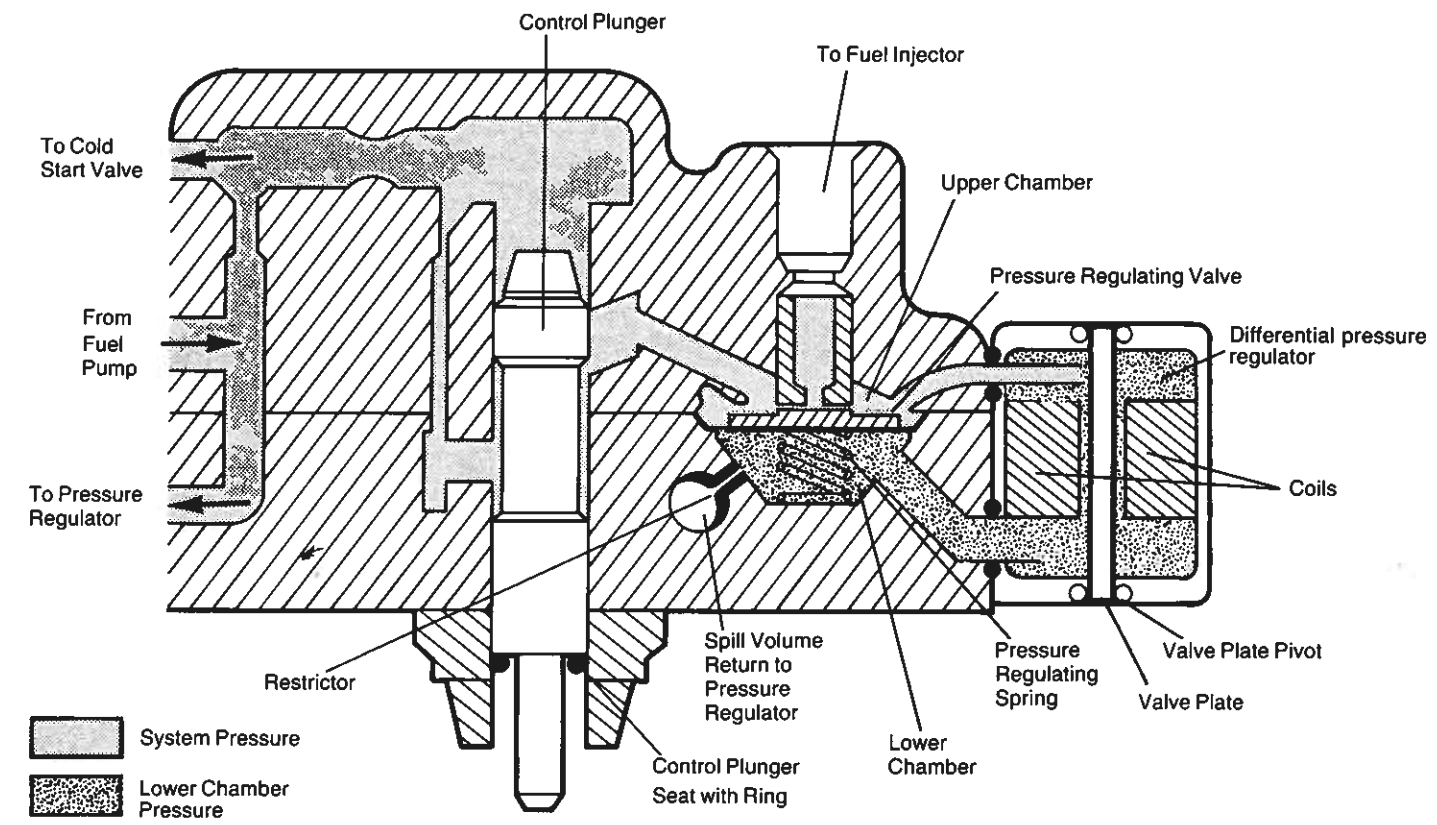

The fuel distributor has many changes to adapt it to CIS electronic. It is now made of aluminum and is slightly smaller than previous versions. Some of the changes are:

- Deletion of pressure relief valve.
- The pressure regulating springs are now in the lower chambers and the differential pressure regulator (electro-hydraulic actuator) is mounted directly to the fuel distributor.
- The volume of the upper chamber is smaller, resulting in quicker response and good hot starting.

- The control plunger now seats on an O-ring with the engine shut-off. There is now a few millimeters play between the sensor plate arm and the control plunger with the engine shut-off.

System pressure is always present in the upper chamber of the fuel distributor. The metering slit in the control barrel regulates the amount of fuel delivered to the upper chamber based on air sensor position and control plunger position. The amount of fuel delivered to the injectors, and consequently the fuel mixture, is adjusted by the differential pressure regulator.

**DIFFERENTIAL PRESSURE REGULATOR
(ELECTRO-HYDRAULIC ACTUATOR)**

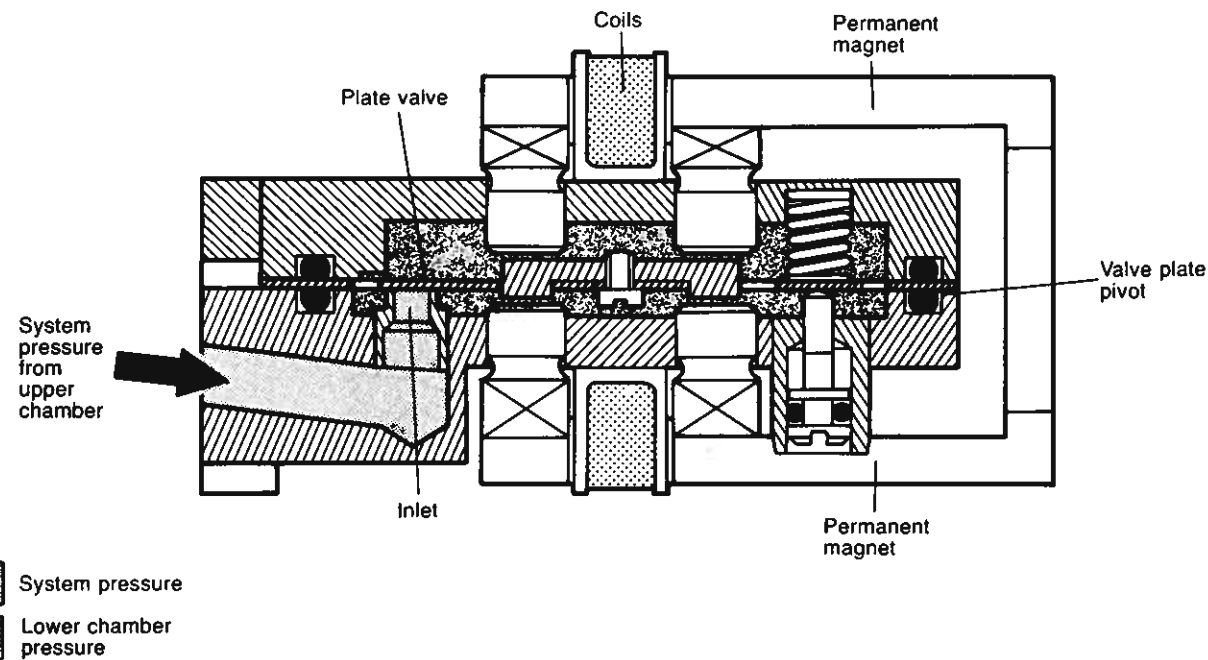

The differential pressure regulator is bolted to the side of the fuel distributor. It consists of a plate valve fastened between two electromagnets. The plate valve regulates the fuel flow into the lower chamber of the fuel distributor. This determines the differential pressure, which is the difference in pressure between the upper and lower chambers in the fuel distributor.

By varying the electric current to the differential pressure regulator and changing the strength of the magnets, the plate valve can be moved. By changing the opening, the quantity of fuel allowed into the lower chamber of the fuel distributor can be regulated. This in turn changes differential pressure.

The differential pressure regulator operating current is supplied by the control unit and is measured in milliamps.

The operating range is from -50 to +150mA. Differential pressure will be from 0 bar to about 1.6 bar (24 PSI) less than system pressure.

The differential pressure regulator is constructed so that without any operating current, such as in an electrical failure, the plate valve would deflect enough under system pressure to maintain a differential pressure of about 0.4 bar. This combined with the 0.2 bar difference caused by the pressure regulating springs in the fuel distributor will result in a difference of 0.2 bar between the upper and lower chambers in the fuel distributor. Since this pressure difference is the same as on the earlier CIS system, the car will still be driveable in the event of an electrical failure. However, it will run roughly because of the resultant lean air/fuel mixture.

Mixture control works like this: based on electrical current supplied to the differential pressure regulator, the valve plate deflects, thereby regulating differential pressure. The pressure difference controls the amount of fuel delivered to the injectors.

When the current supplied to the differential pressure regulator is increased, the plate valve deflects to the right and restricts the flow of fuel to the lower chamber causing the pressure regulating valves to deflect downward. The result is increased fuel flow to the injectors and a richer air/fuel ratio.

When the current supplied to the differential pressure regulator is reduced, the plate valve moves to the left and allows more fuel into the lower chamber. The pressure in the lower chamber increases and deflects the pressure regulating valves upward. The quantity of fuel to the injectors is consequently reduced resulting in a leaner air/fuel mixture.

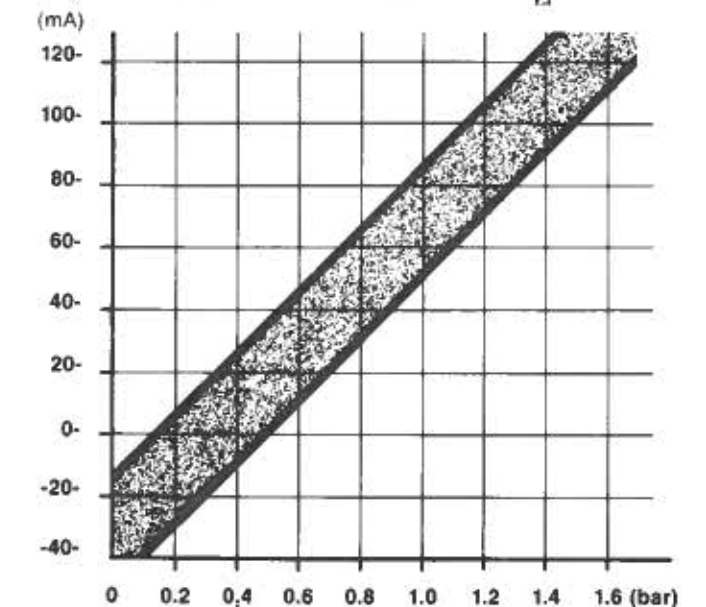
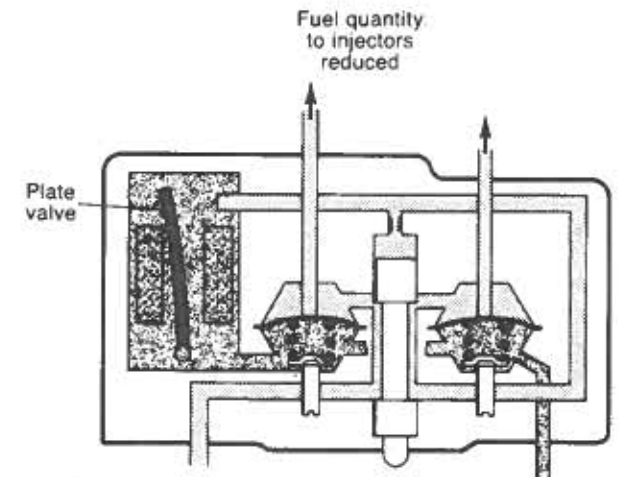
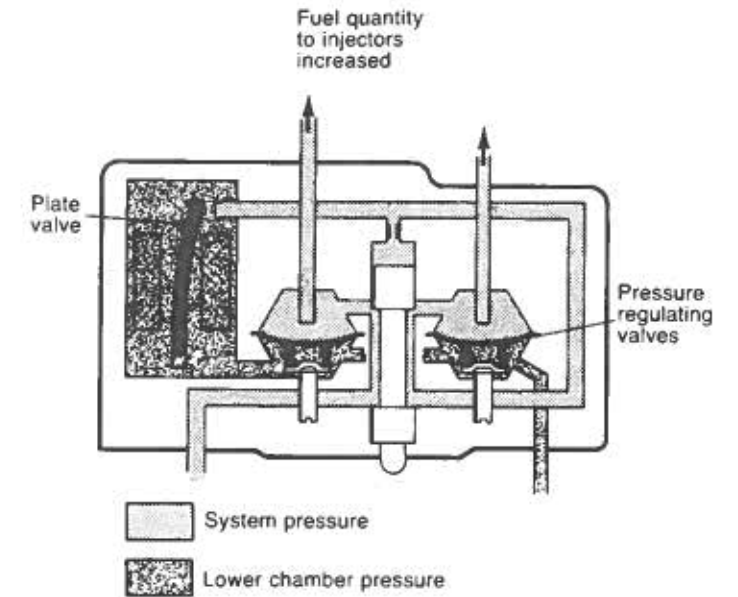

The graph shows the relationship between differential pressure regulator current and the pressure in the lower chamber of the fuel distributor. As current is increased or reduced, the lower chamber pressure is controlled to regulate the fuel flow to the injectors.

The pressure shown is the *difference* between system pressure in the upper chamber of the fuel distributor, and the pressure in the lower chamber.

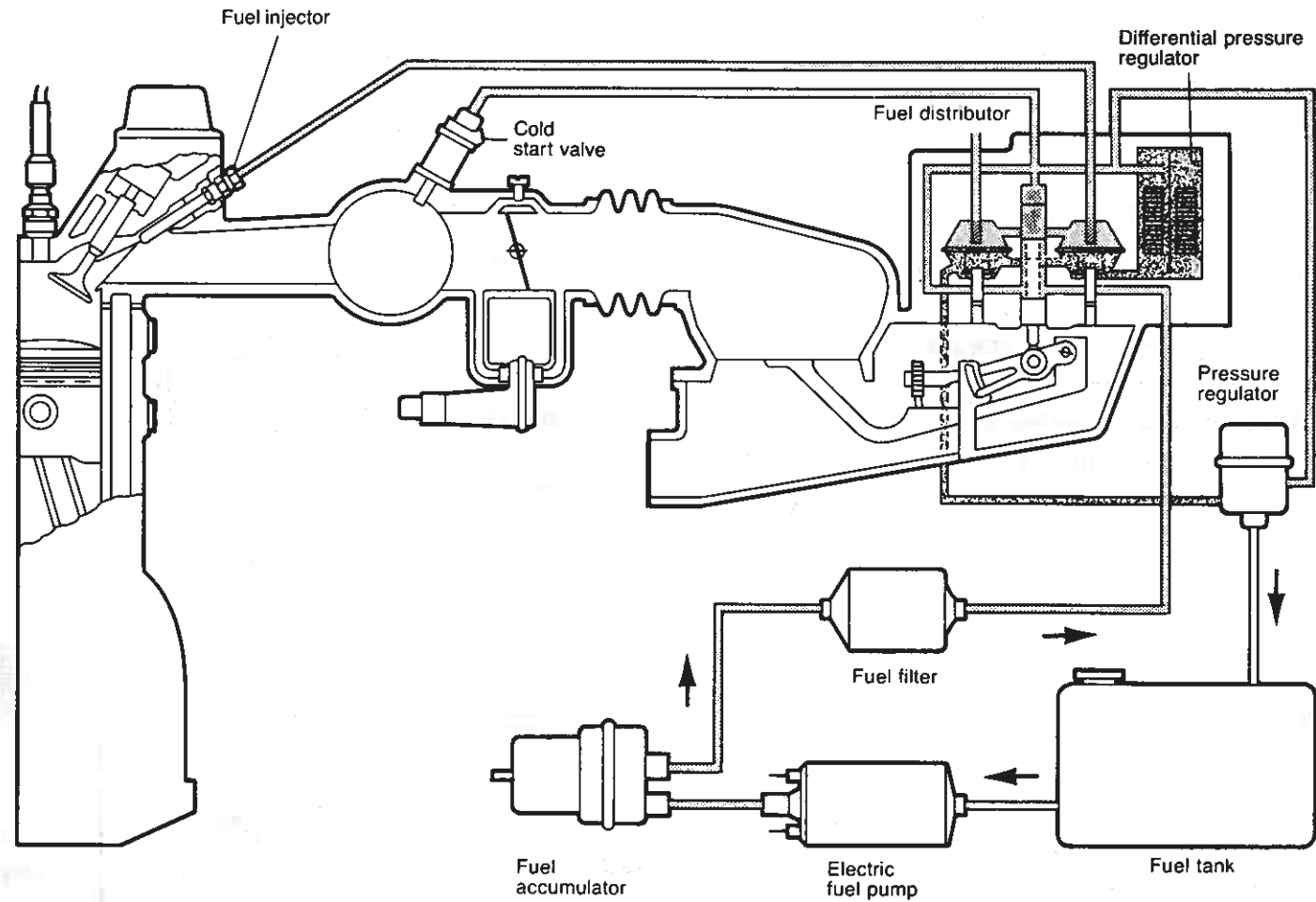

The fuel supply for the CIS electronic system consists of a fuel tank, fuel pump, accumulator, fuel filter, and fuel distributor. The pump delivers fuel from the tank, through a fuel accumulator and filter to the fuel distributor.

The fuel system pressure is determined by a diaphragm type fuel pressure regulator. Differential pressure in the lower chamber of the fuel distributor is determined by differential pressure regulator plate valve position. Excess fuel from the fuel distributor returns to the fuel tank through return lines at a very low pressure.

FUEL PUMP

The roller-cell fuel pump is driven by a permanent magnet electric motor that is located near or inside the fuel tank.

Steel rollers are held in "cut-outs" on the rotor. Centrifugal force seals the rollers against the walls of the pressure chamber as the rotor spins. Fuel that is trapped between the rollers is then forced out the delivery port.

The pump is designed to be both cooled and lubricated by the fuel flowing through it.

Since there is never a combustible mixture inside the pump, there is no possibility of fire.

The pump is subject to damage if it is ever allowed to run "dry."

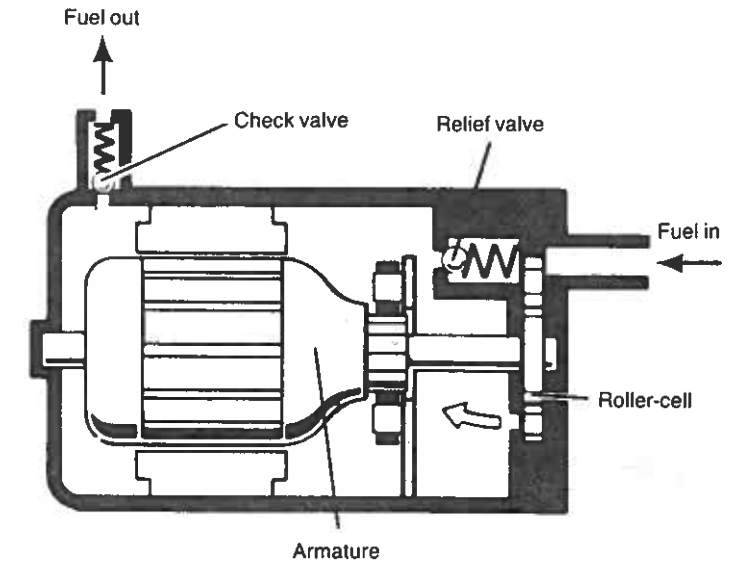

A non-replaceable relief valve is designed to vent fuel back to the intake side of the pump if pressure ever exceeds the normal pressure range.

A replaceable check-valve holds about 2 bar of residual pressure in the system with the engine shut off and seals in conjunction with the pressure regulator to insure quick hot-starting.

Since the pump delivers a greater amount of fuel than is required by the engine at any given time, excess fuel is diverted back to the tank via the pressure regulator, which is located near the fuel distributor.

Some vehicles are equipped with a transfer pump located in the fuel tank and attached to the fuel tank sending unit. This pump delivers fuel to a separate reservoir which supplies the fuel for the main fuel pump.

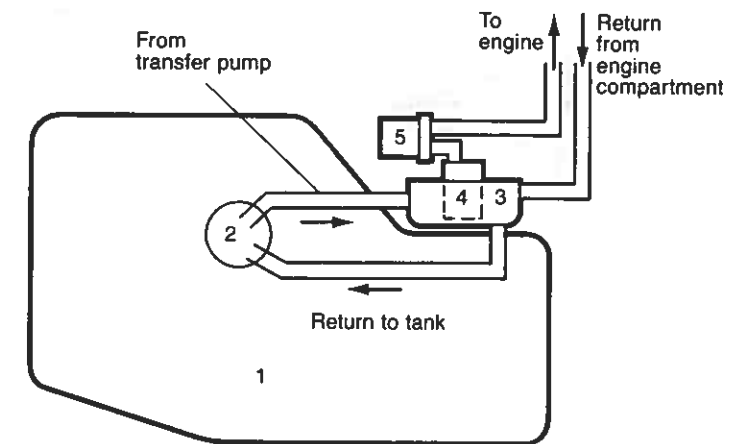
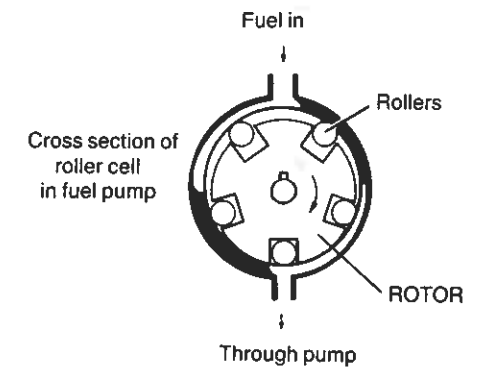

1. Fuel tank
2. Sending unit with transfer pump
3. Fuel supply reservoir
4. Fuel pump
5. Accumulator

ACCUMULATOR

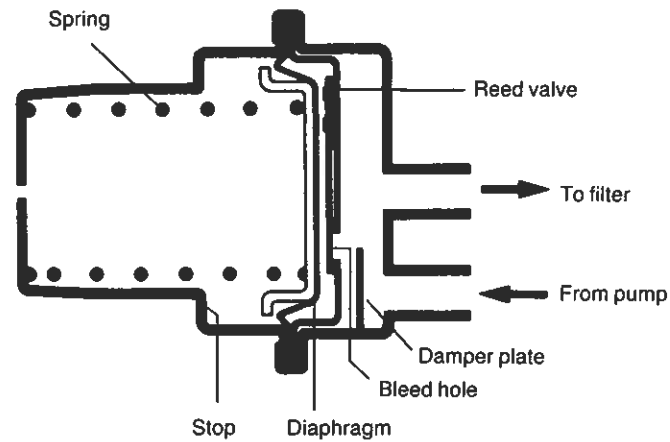

The accumulator is located between the fuel pump and the fuel filter. When the fuel pump is running, the diaphragm moves to the stop against spring pressure. When the fuel pump is off, the fuel is stored under pressure in the accumulator thereby maintaining residual fuel pressure.

The accumulator reduces fuel pump noise as well as protecting the metal diaphragm in the fuel distributor from rapid pressure build-up when the pump begins to run.

SYSTEM PRESSURE

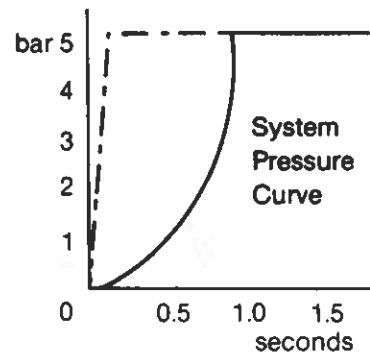

When the fuel pump begins running, the fuel chamber inside the accumulator is filled through the one-way reed valve, and the diaphragm is forced to the left against the spring until it reaches the stop. Only after the diaphragm reaches the stop does system pressure reach its operating limit.

RESIDUAL PRESSURE

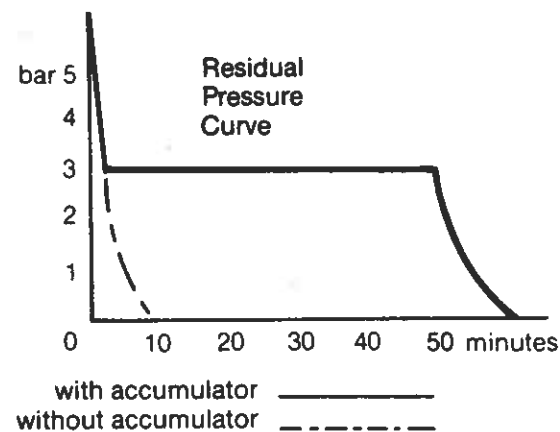

After the engine is turned off, the spring slowly pushes the diaphragm to the right, forcing about 20cc of fuel through a small hole in the reed valve to help maintain residual fuel pressure and avoid fuel vapor lock.

FUEL FILTERS

The fuel filter removes particles from the fuel that might otherwise clog the fuel distributor or injectors.

It is located on the pressure side of the pump so that a possible clogged filter will not damage the pump by causing it to run "dry."

The nylon-paper element inside the filter housing is designed to work best with the fuel flowing in one direction. An arrow on the fuel filter housing denotes the correct installation.

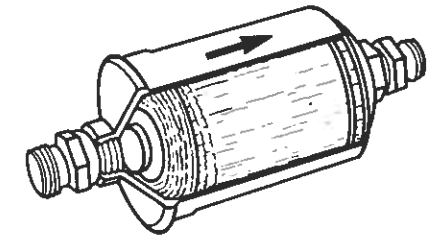

A filter/strainer is also located on the fuel pick-up inside the tank. On vehicles with the transfer pump in the fuel tank, there is a strainer attached to the end of the pump.

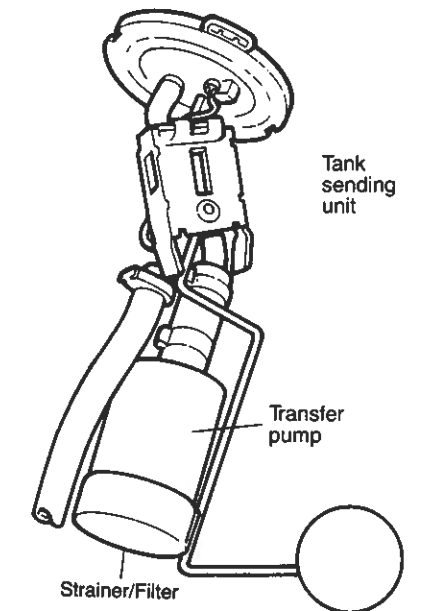

There is a mini fuel filter located in the hollow bolt that connects the pressure line to the fuel distributor.

For replacement intervals for all filters, refer to the maintenance schedule for each particular vehicle.

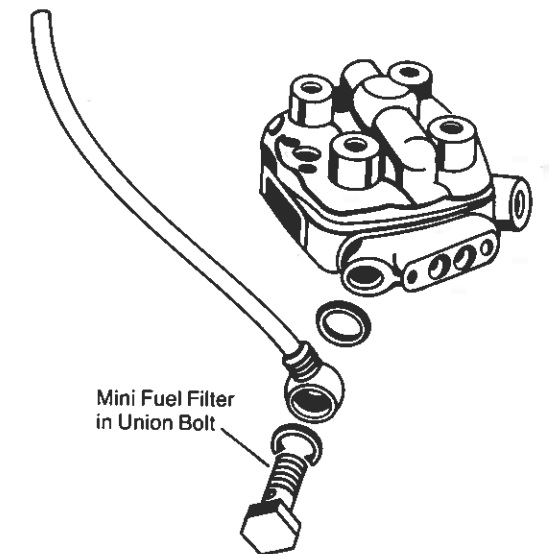

PRESSURE REGULATOR/ENGINE RUNNING

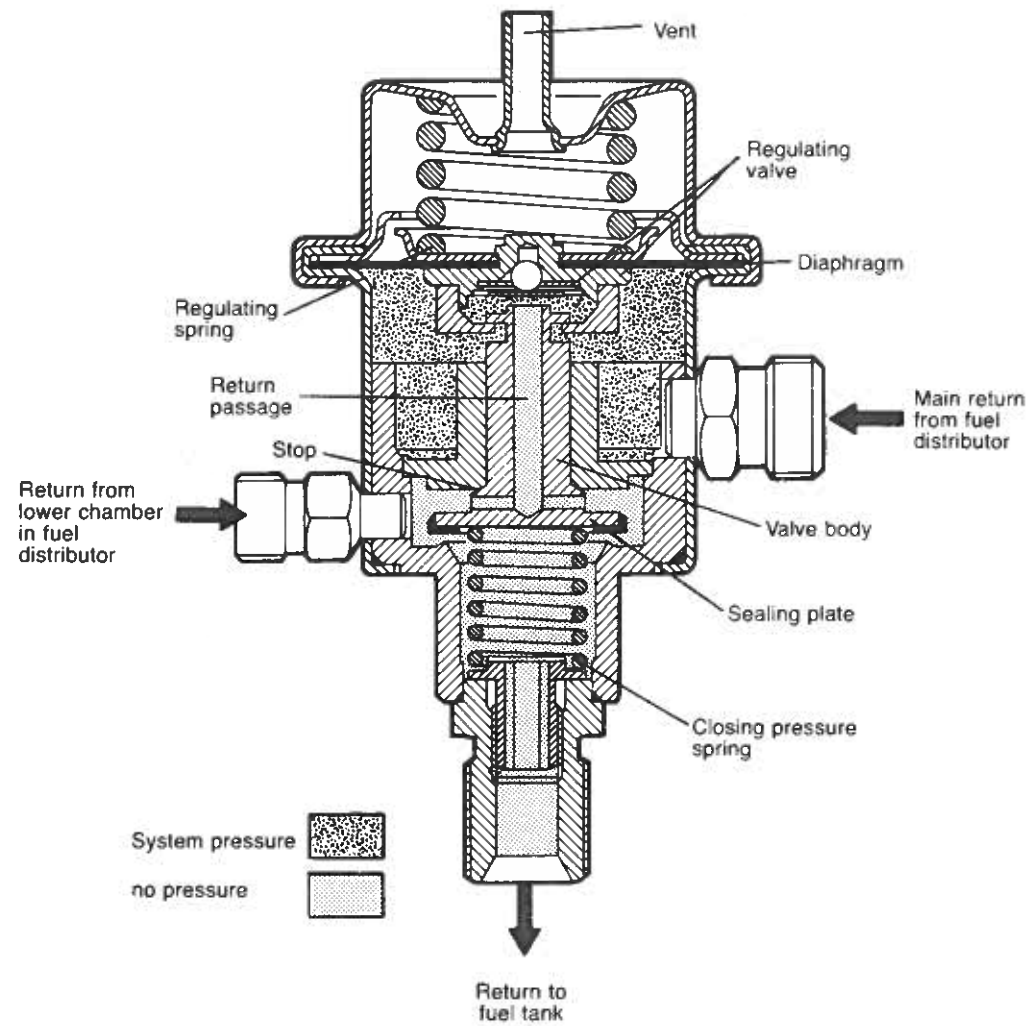

Because of the additional electronic controls a control pressure regulator and pressure relief valve are no longer needed. Instead, a diaphragm type pressure regulator is used to maintain system pressure at approximately 5.4 bar (78.3 PSI).

When the engine is started fuel enters from the main return of the fuel distributor and works against the regulating spring. The

diaphragm assembly moves up along with the valve body which is moved by the closing pressure spring to open the sealing plate. The valve body then contacts its stop and the regulation of system pressure will begin via the regulating valve. The excess fuel along with the spill volume from the lower chamber in the fuel distributor is now returned back to the fuel tank via the opened sealing plate.

PRESSURE REGULATOR/ENGINE SHUT-OFF

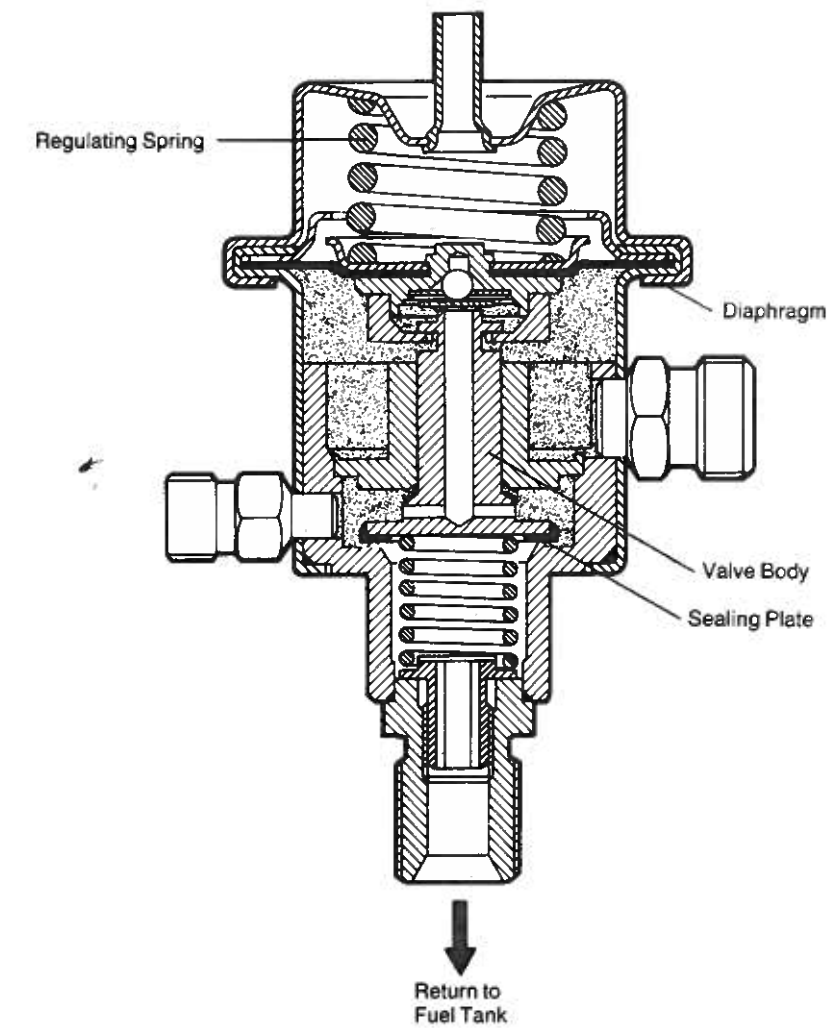

The pressure regulator also acts as one way check valve to maintain pressure in the system once the engine has been shut off. It works like this.

When the engine is shut off the regulating spring will push the diaphragm and valve body down. This will close the sealing plate and shut off the return passageway to the tank thereby maintaining residual pressure in the system.

ALL 4 CYLINDER ENGINES

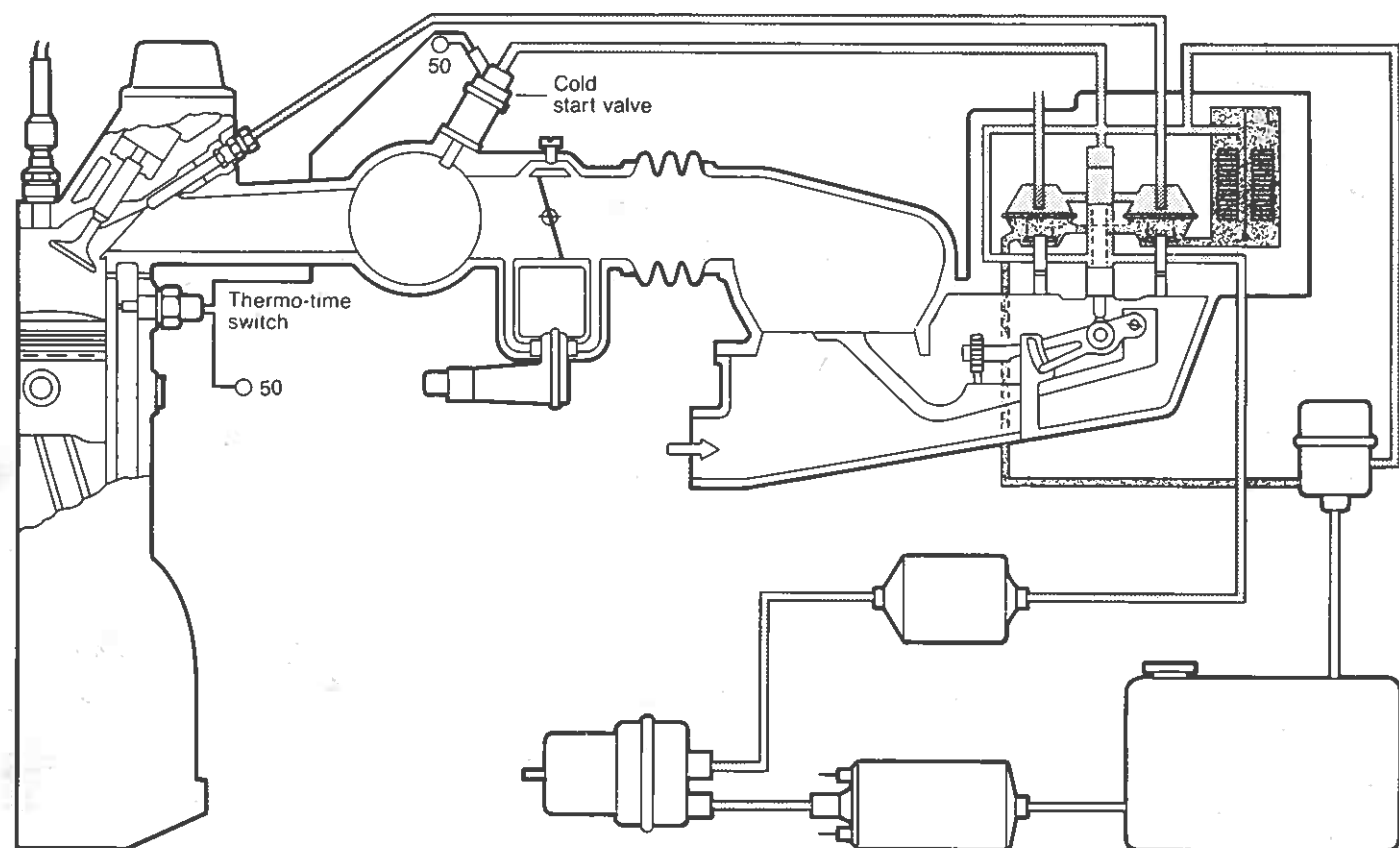

During cold starting a cold start valve, which is located in the intake manifold, provides necessary fuel enrichment to all cylinders. The electro-magnetic coil in the cold start valve receives current from the starter. It is

grounded by the thermo-time switch so that the injector sprays only during cranking. The thermo-time switch controls the cold start valve so that the engine will not flood if it fails to start immediately.

COLD START VALVE

The cold start valve is an electrically operated solenoid valve.

When voltage is applied, fuel is sprayed directly into the intake manifold.

When the valve is **not** energized, it closes and seals.

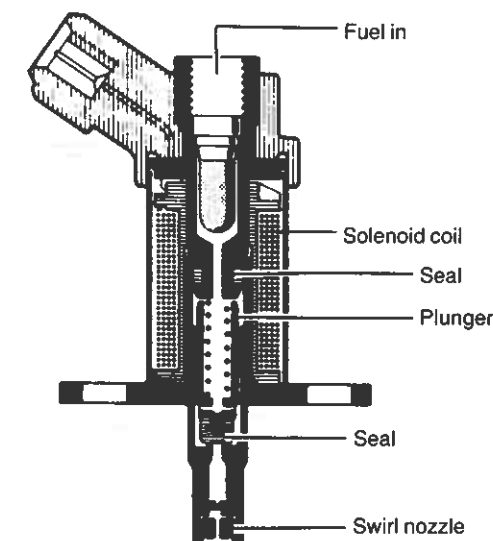

THERMO-TIME SWITCH

The thermo-time switch senses engine temperature and controls the cold start valve according to **temperature and time**.

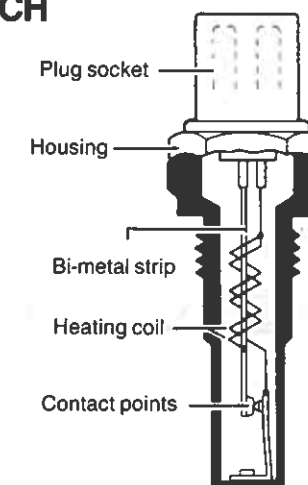

COLD START VALVE WIRING

The cold start valve is wired so that it opens for several seconds when the starter is activated **and** the thermo-time switch provides a ground (cold engine).

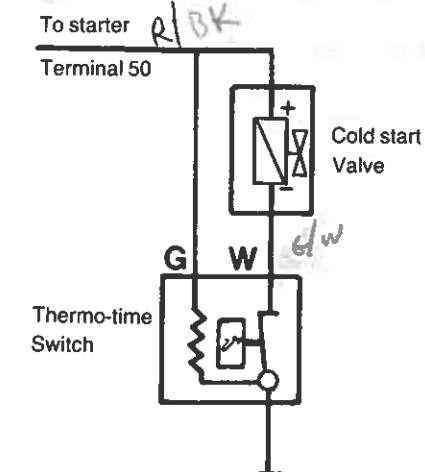

QUANTUM 5 CYLINDER

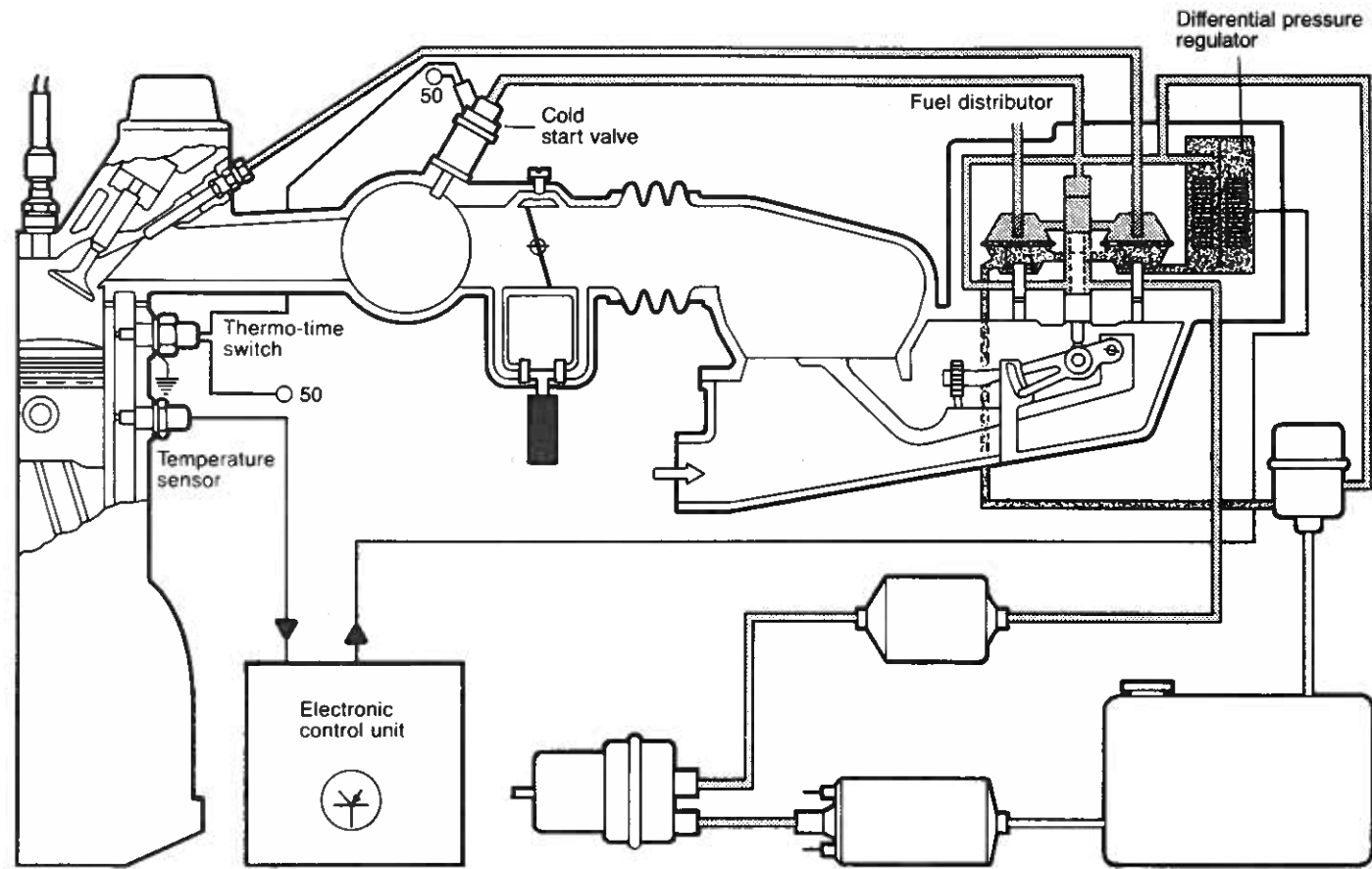

Fuel delivered by the cold start valve is supplemented by additional starting enrichment on some vehicles. This is accomplished in the following manner.

When the starter is activated the control unit increases the current to the differential pressure regulator and the fuel mixture is enriched. The amount of starting enrichment is

dependent upon engine coolant temperature. Maximum starting enrichment time is 1.5 seconds, during which time current to the differential pressure regulator can briefly go as high as 150 mA if the engine is cold. Starting enrichment will also occur with warm engine starting, but is at its greatest level when the engine is cold.

ALL 4 CYLINDER ENGINES EXCEPT GTI AND GLI

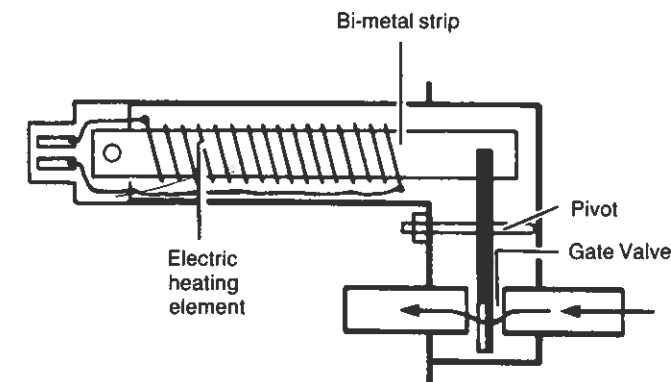
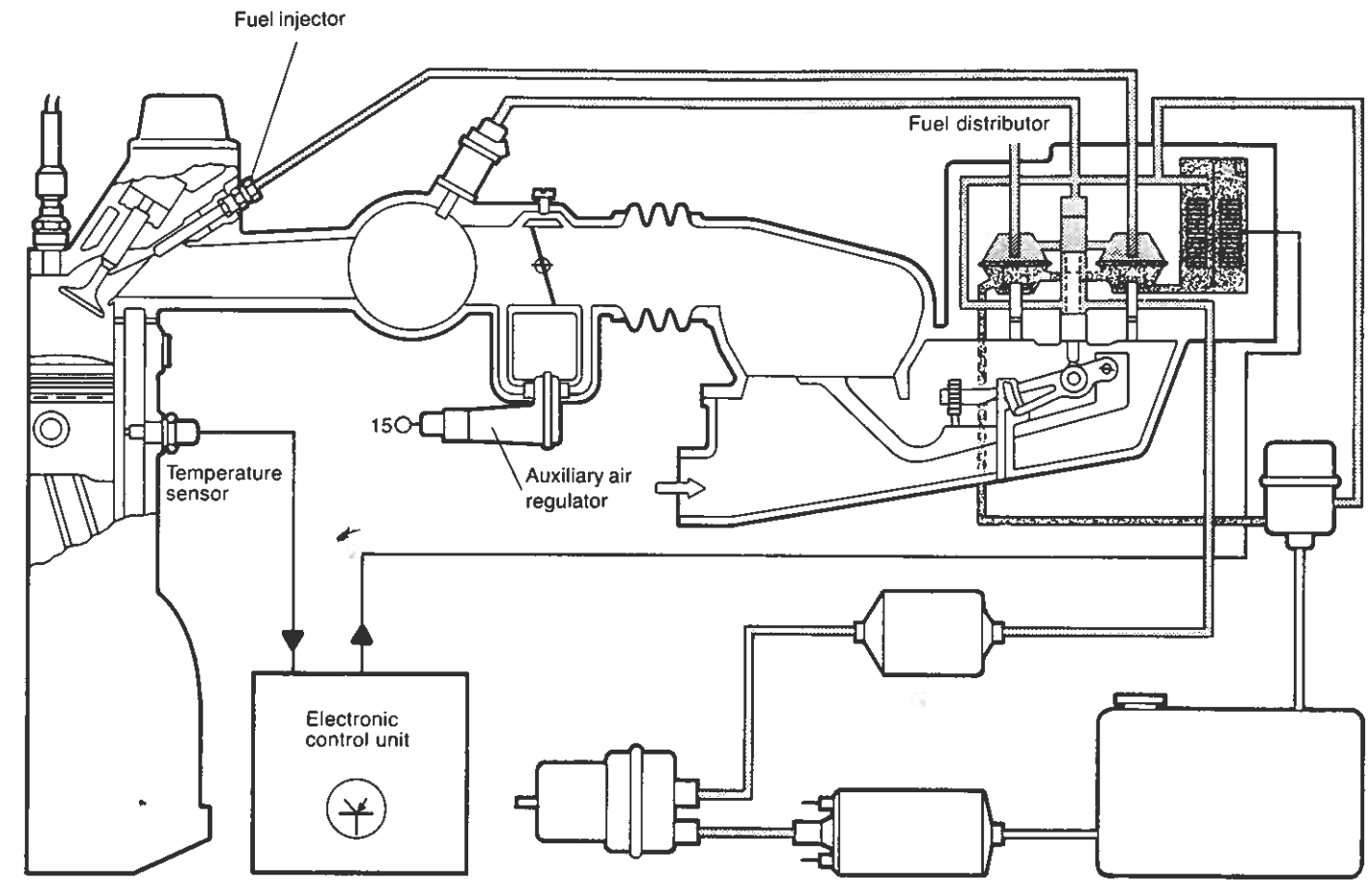

Once the cold engine has started, the **auxiliary air regulator** acts like a "fast idle cam" to slightly increase idle speed while the engine is warming up.

The auxiliary air regulator provides *additional* air for idling during warm up.

When the engine is cold, the **gate valve** is open and air can bypass the closed throttle valve.

After the engine is started, the electric **heating element** warms the **bi-metal strip** which gradually closes the gate valve.

QUANTUM 5 CYLINDER, GTI AND GLI

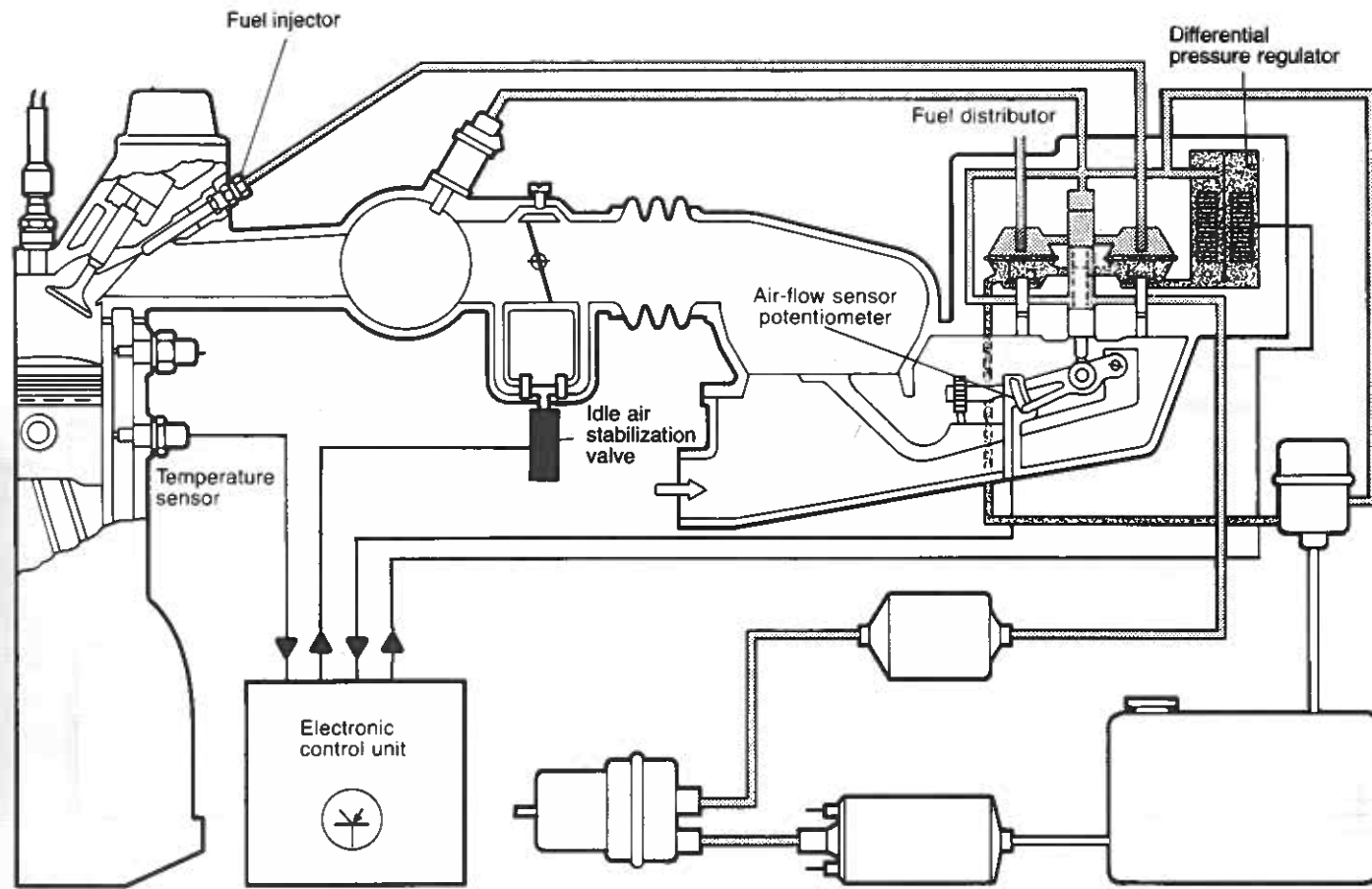

The Quantum 5 cylinder, the GTI and the GLI use an idle air stabilization system in place of the auxiliary air regulator. This system insures that idle speed remains at about 1000 RPM during cold engine operation.

The circuitry for controlling the idle air stabilization valve is incorporated in the fuel injection control unit and is influenced by a signal from the temperature sensor in the engine coolant.

This system insures that the idle speed remains constant at predetermined levels during all engine operating conditions.

The system maintains the following idle RPM for these conditions.

- Engine cold (less than 50°C) = approximately 1000 RPM
- Engine warm (above 50°C) = approximately 850 RPM
- Engine warm and A/C compressor engaged = approximately 900 RPM

The idle air stabilization valve, which eliminates the auxiliary air regulator, consists of an electric motor with two windings and a turning angle of about 90°. The valve is operated by a cycled voltage signal which is generated by the control unit. By regulating the rate of the voltage signal, the valve position can be controlled, resulting in the idle speed being maintained at a predetermined level.

The cycled voltage signal is the same as the signal used to operate a frequency valve in earlier CIS injection systems. A test plug, identical to that of the oxygen sensor system, is located in the engine compartment to test and adjust the system.

The operating range of the system is from about 20% to 80% (18° to 72°).

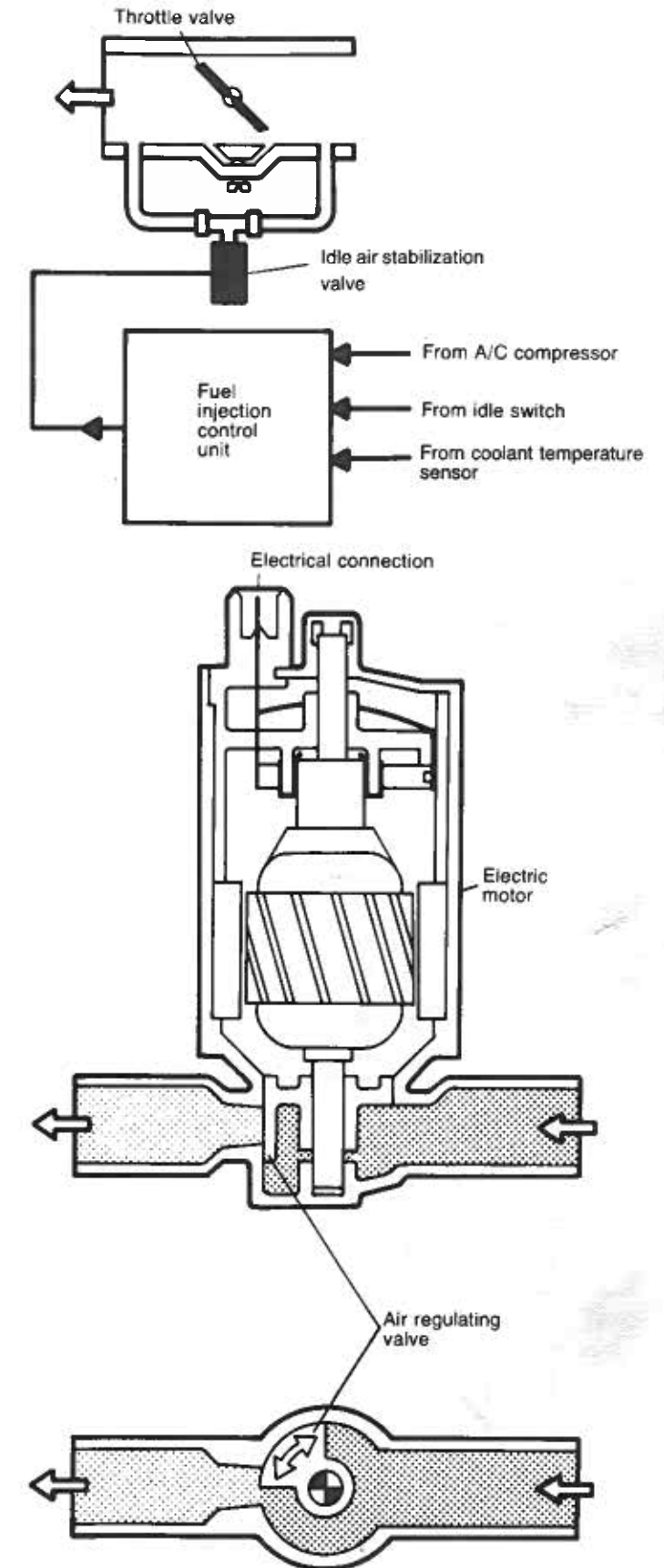

CONTROL UNIT

A 25 pin control unit determines the electronic operation for the fuel injection system. It receives the following inputs:

- Engine temperature
- Engine speed (Quantum 5 cyl., GTI, and GLI)
- Sensor plate position
- Throttle position (Quantum 5 cyl., GTI and GLI)
- Oxygen sensor
- Starter signal
- Atmospheric pressure (Quantum 5 cyl. only)

The control unit generates output signals to the differential pressure regulator based on these inputs, thereby providing the proper air/fuel mixture for all engine operating conditions.

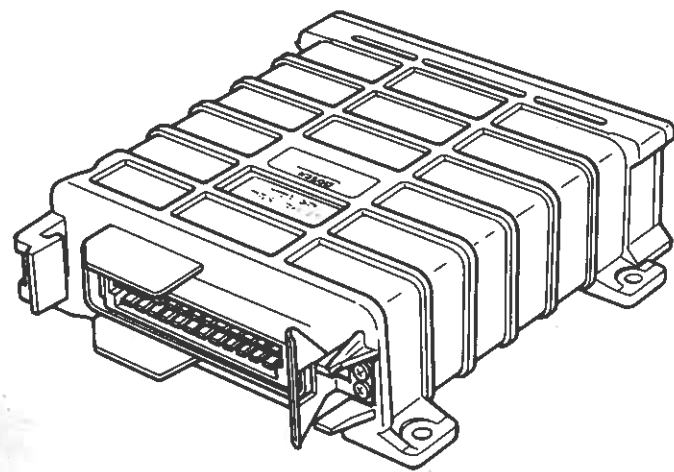

SENSOR PLATE POTENTIOMETER

The sensor plate assembly now uses a potentiometer to measure the position of the sensor plate. It is attached to the side of the air sensor housing.

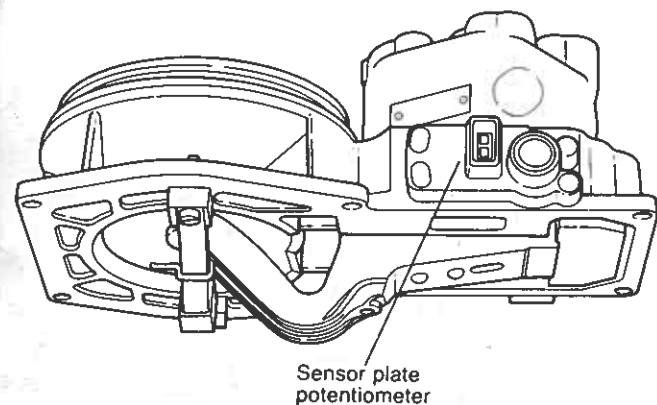

Minimum voltage signal

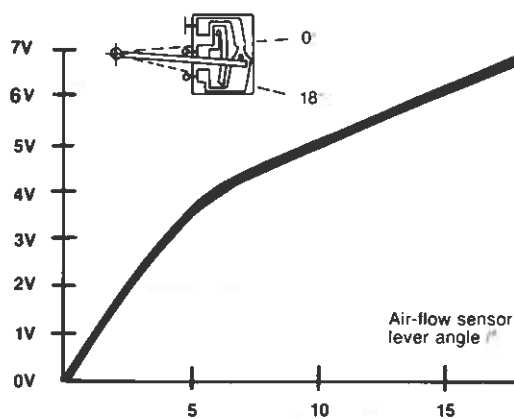

The potentiometer consists of a wiper brush working on a carbon film. It sends a variable voltage signal to the control unit based on sensor plate position. This signal is supplied primarily for cold acceleration enrichment.

COOLANT TEMPERATURE SENSOR

The coolant temperature sensor is threaded into the bottom of the cylinder head coolant outlet and senses the temperature of the coolant.

The sensor is a negative temperature coefficient (NTC) resistor, which means that its resistance decreases as coolant temperature increases (see graph).

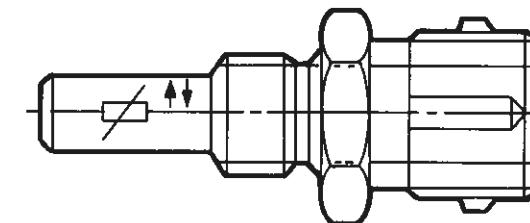

A signal from the temperature sensor enables the control unit to provide additional fuel to the injectors during starting and engine warm-up. The lower the temperature of the coolant, the more fuel that is provided to the engine.

The graph illustrates that temperature sensor resistance decreases gradually during engine warm-up so that the air/fuel mixture is correct for all operating temperatures.

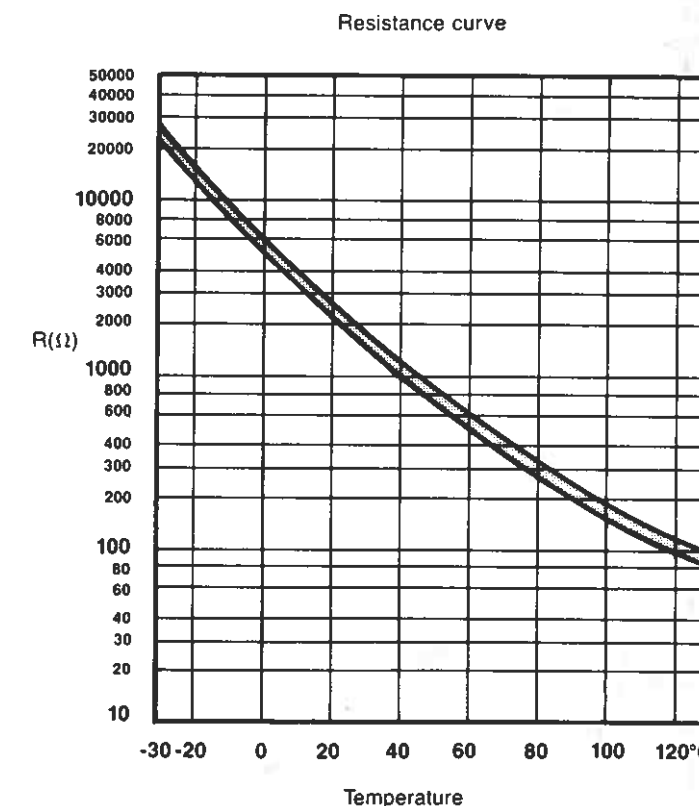

AFTER-START ENRICHMENT AND WARM-UP ENRICHMENT

After the engine has started the control unit continues to enrich the mixture through increased differential pressure regulator current. This insures that the engine runs smoothly when it is cold. The level of after-start enrichment is dependent on engine coolant temperature, and lasts approximately 40 seconds. While the engine is warming-up, fuel enrichment continues based on coolant temperature. This warm-up enrichment continues at a lower level than after-start enrichment and decreases as the engine reaches operating temperature. The following graph illustrates these functions.

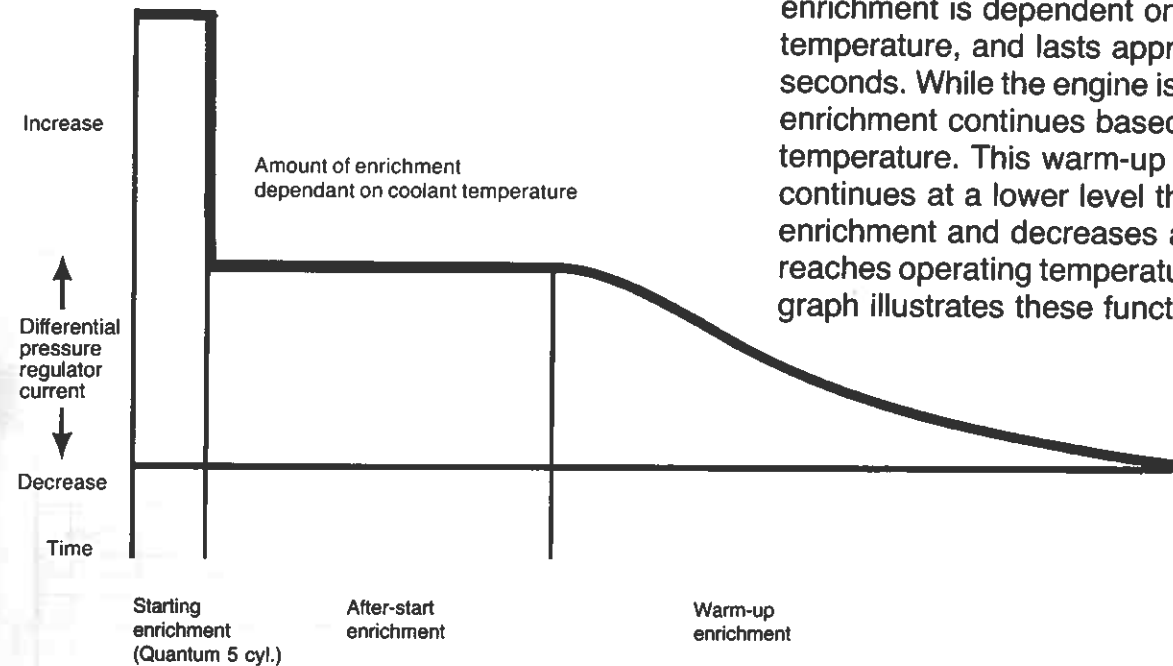

ACCELERATION ENRICHMENT

Acceleration enrichment will also only take place when the engine is below normal operating temperature and is only effective for a few seconds. The amount of acceleration enrichment is dependent upon:

- Engine coolant temperature
- Movement speed of the sensor plate
- Total travel of the sensor plate

The resistance curve of the sensor plate potentiometer is such that the rate of enrichment is greater at lower engine speed and less at higher engine speed.

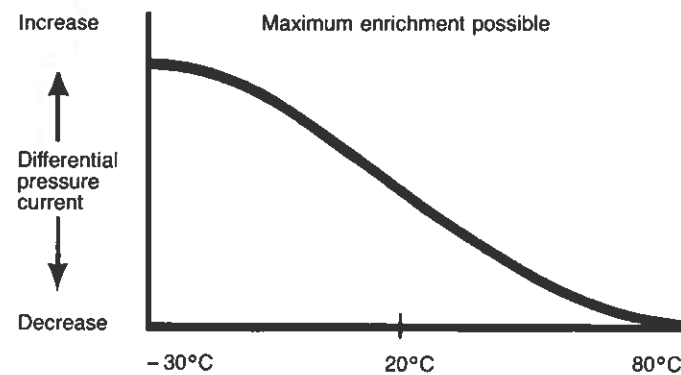

OXYGEN SENSOR

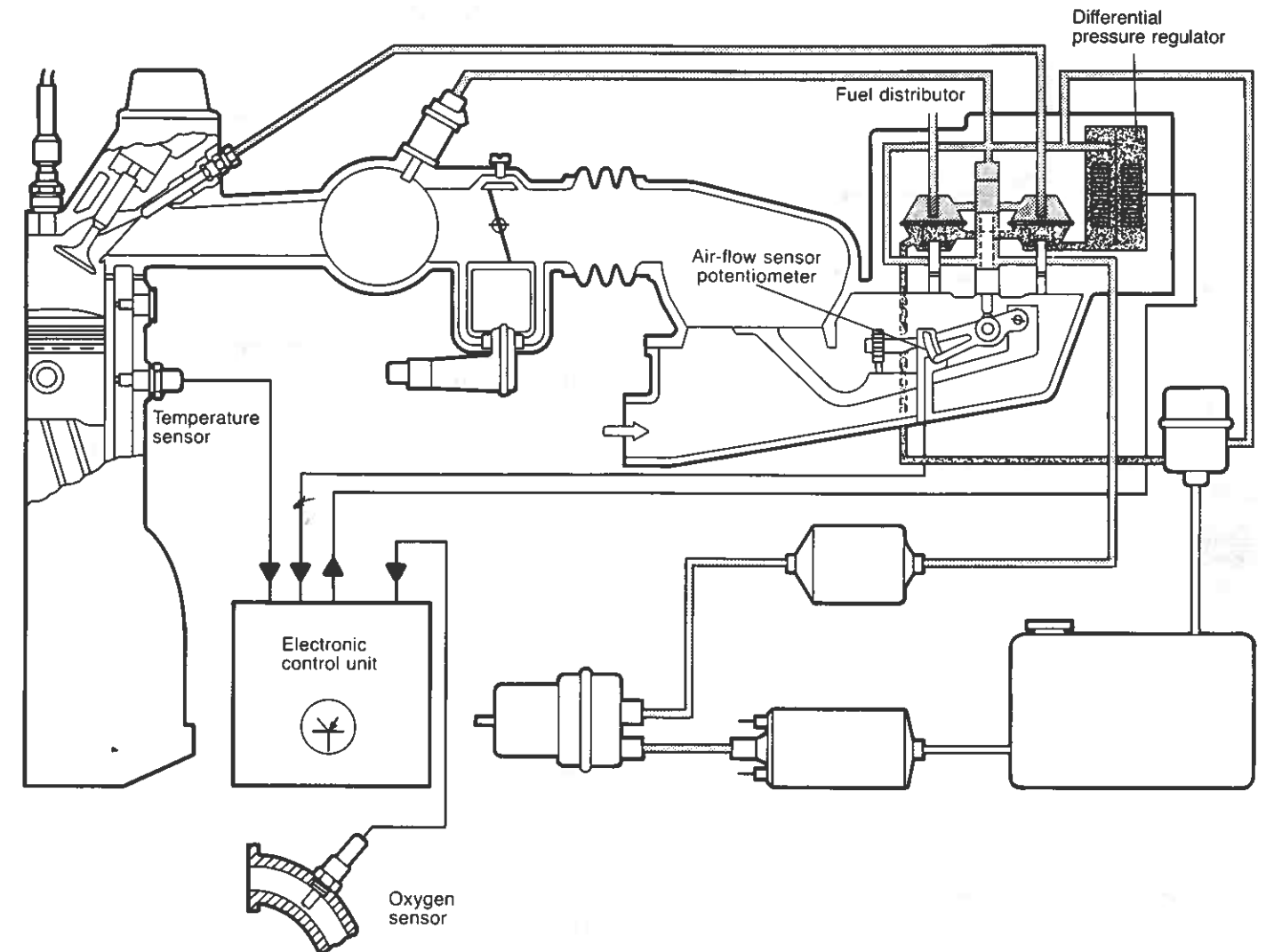

An oxygen sensor system with a 3-way catalytic converter is used on all cars with CIS Electronic Fuel Injection.

A separate oxygen sensor control unit and frequency valve are not needed. Instead, once the engine reaches operating temperature the control unit processes the voltage signal from the oxygen sensor and adjusts the differential pressure regulator current accordingly. The operating range of the differential pressure regulator during oxygen sensor regulation is from 0 to 20 mA.

On vehicles with CIS electronic fuel injection, the oxygen sensor sends a varying voltage signal to the control unit based on the amount of oxygen in the exhaust. The control unit then signals the differential pressure regulator which changes the quantity of fuel delivered to the injectors.

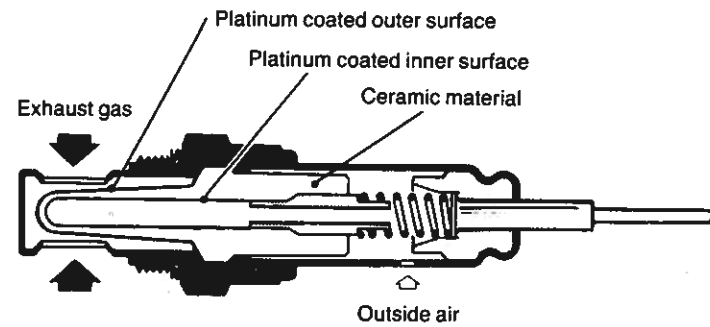

The oxygen sensor is made of a ceramic material called Zirconium dioxide. The inner and outer surfaces of the ceramic material are coated with platinum. The outer platinum surface is exposed to the exhaust gas, while the inner surface is exposed to the outside air.

The difference in the amount of oxygen contacting the inner and outer surfaces of the sensor creates a pressure differential which results in a small voltage signal of between 175 to 1100 mV being supplied to the control unit. A high voltage signal indicates a rich mixture, and if the mixture is lean, a low voltage signal will be sent to the control unit.

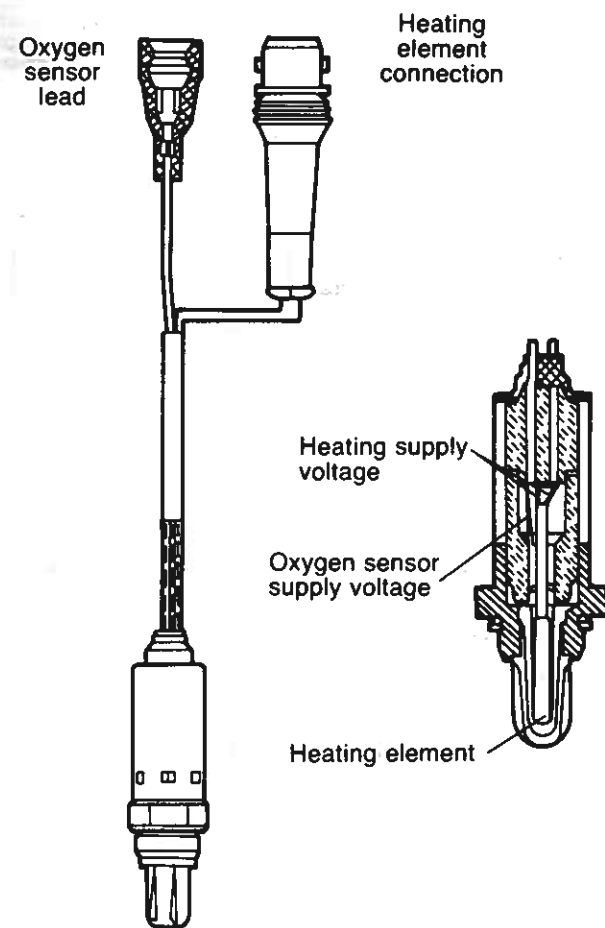

On the GTI and GLI, the oxygen sensor is heated electrically to keep it at a constant operating temperature. This insures continuous and accurate reaction of the sensor during all operating conditions.

The heated oxygen sensor has three wires, two for the heating element (ground and power) and a signal wire for the oxygen sensor. Power is supplied to the heating element whenever the engine is running.

The oxygen sensor system operates like this. If the amount of oxygen in the exhaust system is low, indicating a rich mixture, the sensor voltage will be high. This signal, about 1100 mV, is sent to the control unit. The electronic control unit then reduces the current signal to the differential pressure regulator.

When the current to the differential pressure regulator is reduced the plate valve will move to the left and allow more fuel into the lower chamber. The pressure in the lower chamber will then increase and deflect the pressure regulating valves upward. The quantity of fuel delivered to the injectors is then reduced and the fuel mixture is leaned.

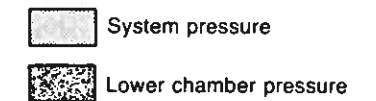
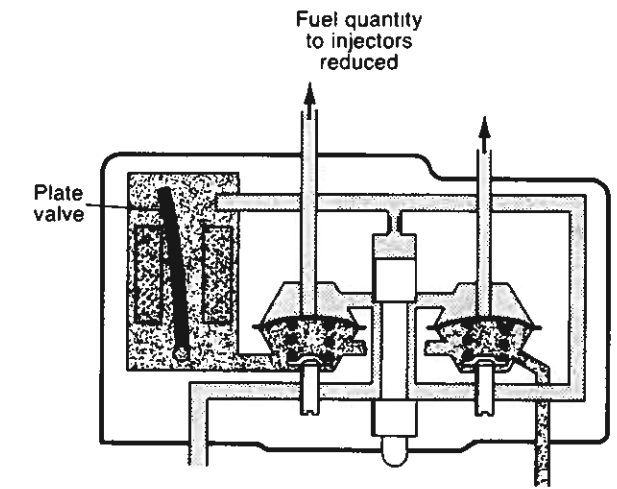

If the mixture is lean, the oxygen sensor will send a low voltage signal of about 175 mV to the electronic control unit. The control unit will increase the current to the differential pressure regulator.

When current to the differential pressure regulator is increased, the plate valve will deflect to the right and restrict the flow of fuel to the lower chamber. This reduces the pressure in the lower chamber causing the pressure regulating valves to deflect downward. The result is increased fuel flow to the injectors and an enriched fuel mixture.

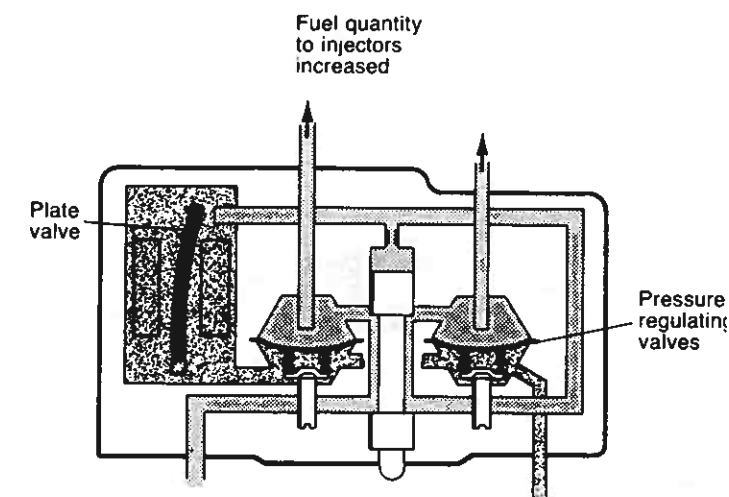

ALTITUDE CORRECTION

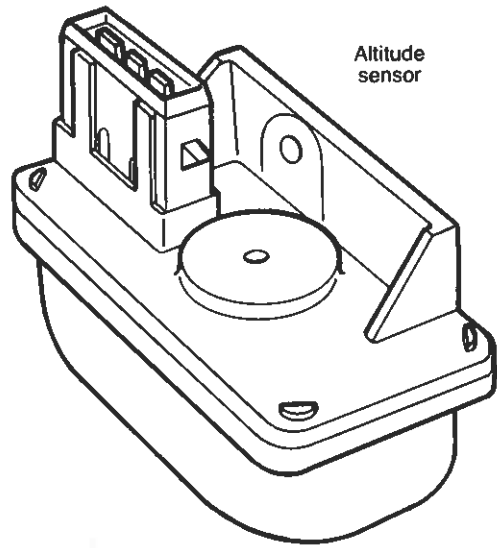

Quantums with 5 cylinder engines use an altitude sensor that is mounted next to the control unit. This sensor is used to send a voltage signal to the control unit that is based on altitude. The signal is used to adjust the fuel mixture for changes in air pressure. The altitude compensation function operates in the following manner.

In areas of high altitude the air pressure is lower than at sea level. This results in the air being "thinner" or less dense, which means the engine will have less oxygen to burn. Under this condition, the altitude sensor sends a resistance signal to the control unit. This resistance signal results in a lower current being sent to the differential pressure regulator. As a result, less fuel is delivered to the engine to maintain the correct air/fuel ratio.

In areas below sea level, air pressure is higher than at sea level. This results in the air being more dense, which means there is more oxygen available to support combustion. If not compensated for, this extra oxygen would result in a lean air/fuel mixture. In this instance, the altitude sensor sends a voltage signal to the control unit which then increases the current to the differential pressure regulator and the mixture is enriched.

At sea level the sensor is open and has no effect on the fuel mixture. The change in differential pressure regulator current is effective in all operating modes of the fuel injection system. The graph illustrates the amount of altitude compensation.

Change in differential pressure regulator current = about 1mA per 1000 ft. elevation change

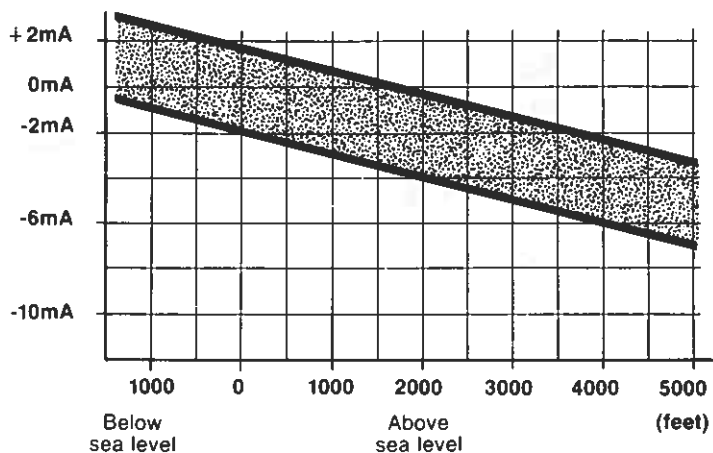

FULL THROTTLE ENRICHMENT

The Quantum 5 cyl., GTI, and GLI are equipped with full throttle enrichment. Full throttle enrichment will only take place after the engine has reached operating temperature and provides additional fuel for the increased performance requirements of the engine.

When engine speed is above 4000 RPM, and the throttle is fully open, the full throttle switch, located on the throttle housing, closes sending a voltage signal to the electronic control unit. The control unit increases differential pressure regulator current to a fixed rate that is approximately 3 mA above the basic adjustment value to enrich the fuel mixture.

DECELERATION FUEL SHUT-OFF

The Quantum 5 cyl., GTI and GLI also incorporate a deceleration fuel shut-off feature to help improve fuel economy. During engine deceleration, the control unit reverses the current to the differential pressure regulator to about -40 mA. This opens the plate valve and allows system pressure to work on the lower chambers. System pressure combined with the pressure regulating springs closes the regulating valves and shuts off the flow of fuel to the injectors.

To insure that the fuel shut-off feature operates smoothly, the point at which shut-off begins and ends is influenced by engine coolant temperature. If the engine is below operating temperature, the cut-in and cut-off points are raised accordingly. When the engine is at operating temperature cut-off will occur when:

- Engine speed is above approximately 1600 RPM
- The throttle is closed

Fuel flow to the injectors will be resumed when engine speed drops below approximately 1300 RPM.

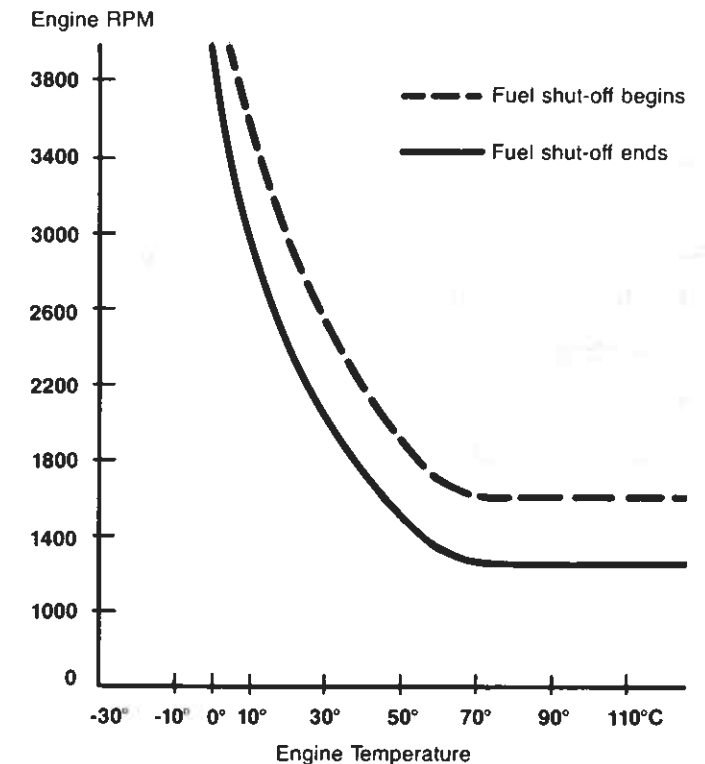
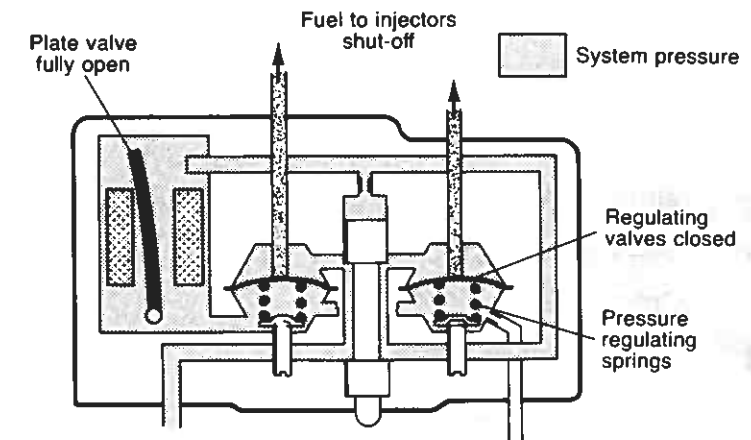

Test procedures for CIS electronic components are explained in the following section of this book. Depending on the symptoms, the problem may fall into one of the following categories 1) Cold Starting, 2) Hot Starting, 3) Cold Running, and 4) Warm Running.

COLD STARTING

Symptom:

- Cold engine does not start
- Cold engine difficult to start

Preliminary Checks:

- Starting procedure OK
- Cranking speed OK
- Ignition system OK
- Compression OK

Check:

- Timing, idle speed, CO% (pp. 32-36)
- Cold start valve/thermo-time switch (pg. 50)
- System operational checks (pp. 40-41)
- Sensor plate height, center and clearance (pp. 44-45, 47)
- Sensor plate — check for binding (pg. 46)

HOT STARTING

Symptom:

- Warm engine does not start
- Warm engine difficult to start

Preliminary Checks:

- Starting procedure OK
- Cranking speed OK
- Cranking time (within 10 seconds) OK
- Ignition system OK
- Compression OK
- Intake system leaks (hoses/boots/injector seals and inserts etc.)

Check:

- Timing, idle speed, CO% (pp. 32-36)
- Oxygen sensor system operation (pp. 41-42)
- Residual pressure (pg. 40)
- Sensor plate height, center and clearance (pp. 44-45, 47)
- Injector bench test, Injector quantity (pp. 53-55)
- Fuel pump delivery (pg. 53)

COLD RUNNING

Symptom:

- Cold engine starts and stalls
- Cold engine runs poorly

Preliminary Checks:

- Starting procedure OK
- Ignition system OK
- Compression OK
- Vacuum hose routing OK
- Intake system leaks (hoses/boots/injector seals & inserts etc.)

Check:

- Timing, idle speed, CO% (pp. 32-36)

- Auxiliary air regulator (pg. 51)
- Sensor plate — center (pg. 47)
- Oxygen sensor system — operation (pp. 41-42)
- Sensor plate — check for binding (pg. 46)
- Differential pressure (II) (pp. 38-39)
- Potentiometer (pg. 48)
- System operational checks (pp. 40-41)
- System pressure (pg. 37)
- Altitude compensation device (Quantum 5 cyl.) (pg. 43)
- Idle air stabilization checks (Quantum 5 cyl. GTI and GLI) (pg. 56)

WARM RUNNING

Symptom:

- Warm engine runs poorly

Preliminary Checks:

- Ignition system OK
- Compression OK
- Vacuum hose routing OK
- Intake system leaks (hoses/boots/injector seals & inserts etc.)

Check:

- Timing, idle speed, CO% (pp. 32-36)
- System pressure (pg. 37)

- Oxygen sensor system — operation (pp. 41-42)
- Injector quantity, injector bench test (pp. 53-55)
- Fuel pump delivery (pg. 53)
- Sensor plate — center (pg. 47)
- Sensor plate — check for binding (pg. 46)
- Altitude compensation device (Quantum 5 cyl.) (pg. 43)
- Differential pressure (I) (pg. 38)
- Basic throttle position (pg. 52)
- Idle air stabilization checks (Quantum 5 cyl. GTI, and GLI) (pg. 56)

CHECKING 4 CYLINDER ENGINES (EXCEPT GTI AND GLI)

Siemens 451 or VW 1367

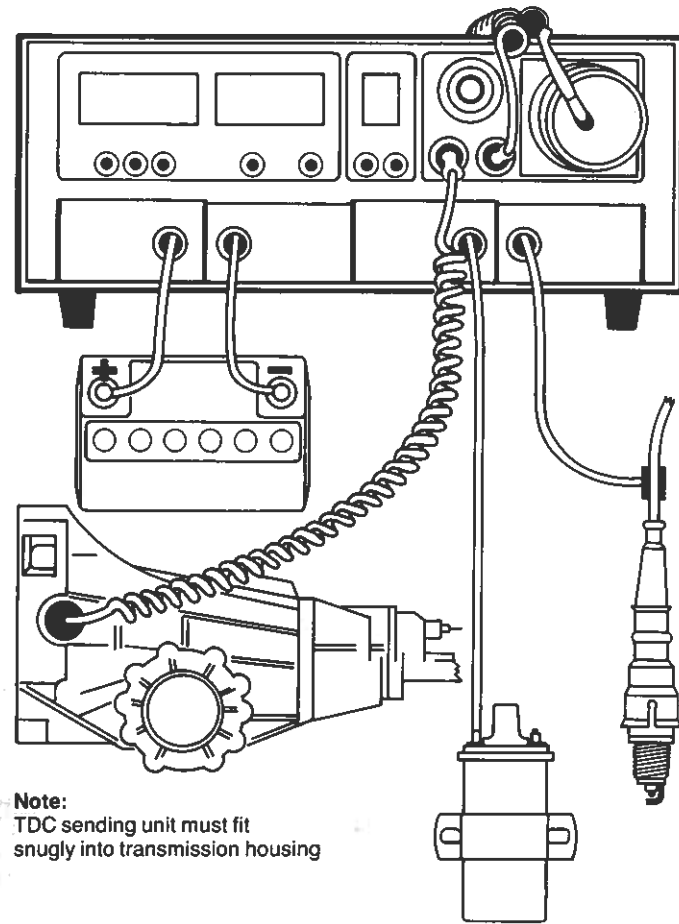

Note:
TDC sending unit must fit snugly into transmission housing

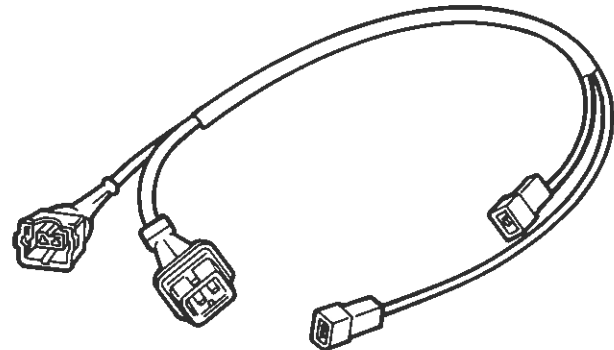

VW 1315 A/1

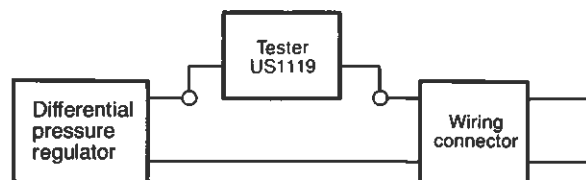

- Engine oil temperature minimum 80° C (176° F)
- All electrical consumers switched off
- Oxygen sensor connected
- Connect engine tester according to manufacturer's instructions
- Pinch supply hose for idle air bypass valves
- Remove cap from CO probe receptacle
- Connect CO tester to probe receptacle
Hose must fit snugly so there is no exhaust leak
- Remove wiring connector from the differential pressure regulator
- Connect adaptor VW 1315 A/1 and multimeter US 1119 between the differential pressure regulator and the wiring connector
Set multimeter to 200 mA scale
- Start engine
- Check idle speed
900 ± 100 RPM
- Check ignition timing
6° ± 2° BTDC
- Check differential pressure regulator current
10 mA ± 6 mA and fluctuating
- Check CO%
0.3% to 1.2%
- If within specifications, shut off engine and continue with fuel system pressure checks
- If not within specifications, continue with adjusting procedure

ADJUSTING 4 CYLINDER ENGINES (EXCEPT GTI AND GLI)

- Remove "T" connection from carbon canister at intake air boot.
- Turn "T" piece 90° and insert blank side with 1.5mm restrictor into hole in intake air boot.
NOTE: If car is not equipped with this type of connector, use part #026-133-382D or equivalent plug with 1.5mm orifice.
- Remove both crankcase vent hoses and vent to atmosphere.
- Start engine
- Adjust idle speed
900 ± 30 RPM
- Adjust timing
6° ± 1° BTDC
- Adjust differential pressure regulator current
10 ± 1 mA and fluctuating
- Check CO%
0.3% to 1.2%
- Note that the current reading should fluctuate within the specified range
- A current reading that does not fluctuate indicates a problem with the oxygen sensor system
- Readjust idle speed if necessary

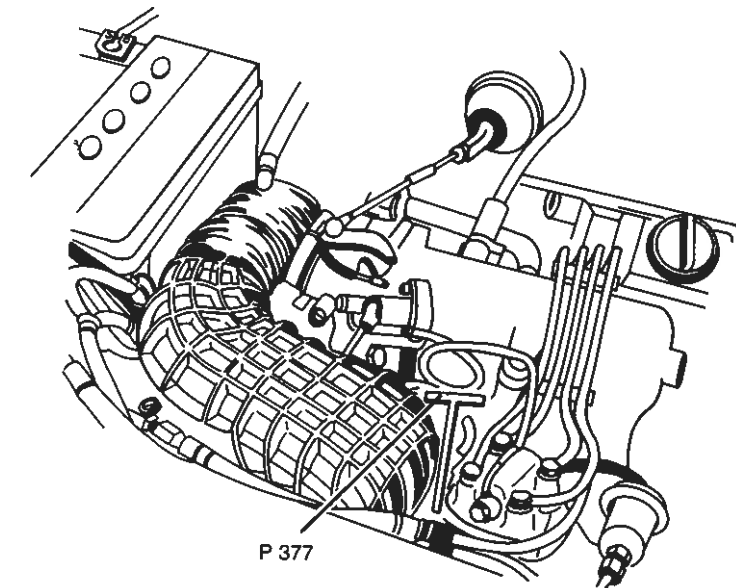
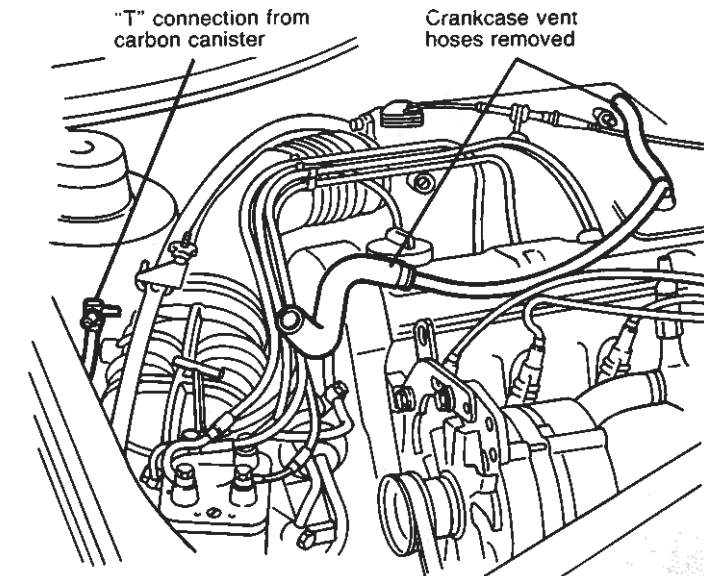

P 377

CHECKING QUANTUM 5 CYLINDER, GTI AND GLI

- Engine oil temperature minimum 80° C (176° F)
- All electrical consumers switched off
- Oxygen sensor connected
- Remove cap from CO probe receptacle
- Connect CO tester
- Hose must fit snugly so that there is no exhaust leak
- Remove wiring connector from differential pressure regulator
- Connect adaptor VW 1315 A/1 and multimeter US1119
- Set multimeter to 200 mA scale
- Connect engine tester to test plug using adaptor US1112 and set tester to 4 cylinder scale

NOTE: Only connect the (+) and (-) and (dwell) leads of VW 1367 or Siemens 451. If other test leads are connected the "duty cycle" readings for the idle air stabilization valve will be inaccurate.

- Start engine
 - Check duty cycle of idle air stabilization valve
 - Shut off engine
- 28% ± 2% (23° - 27°)

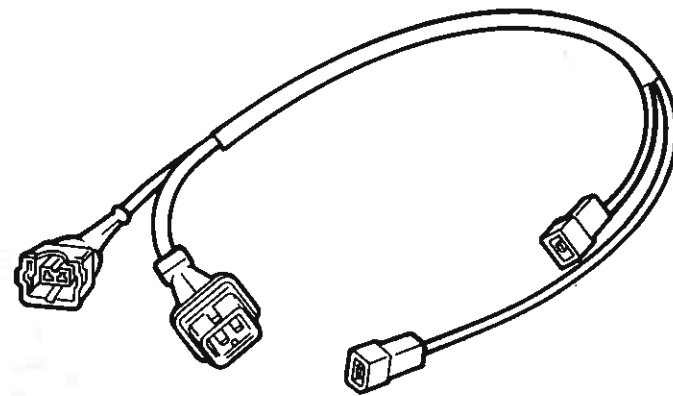

VW 1315 A/1

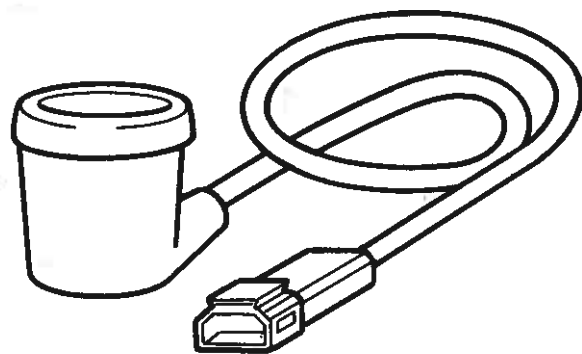
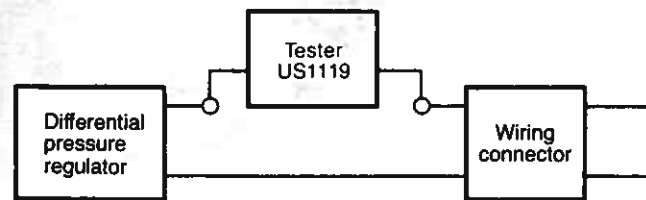

Adapter US 1112

- Reconnect engine tester to make idle RPM and ignition timing checks
- Start engine
- Check idle RPM
- 800+ 50 RPM for Quantum
- 850 +100 RPM for GTI and GLI
- Check ignition timing
- 6° ± 2° BTDC

- Check CO%
- 0.3% to 1.2%
- Check differential pressure regulator current
- GTI and GLI — 10mA ± 6mA
- Quantum — refer to graph below
- If all values are within specifications shut off engine and continue with fuel system pressure checks, page 37
- If all values are not within specifications, continue with adjusting procedure

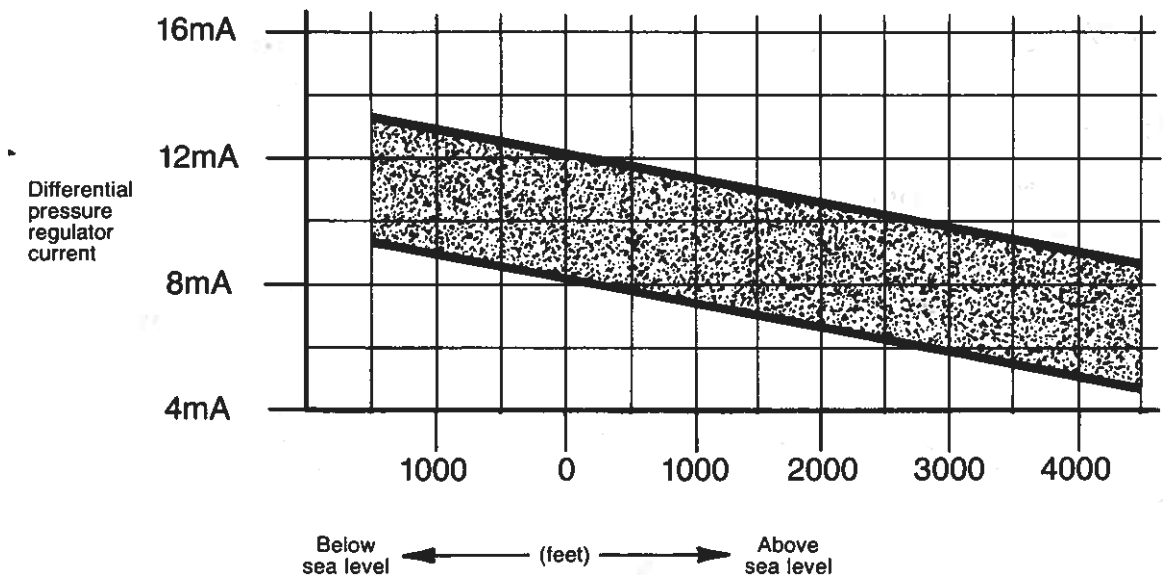

ADJUSTING QUANTUM 5 CYLINDER, GTI AND GLI

- Remove cap from carbon canister purge line

Note: On Golf and Jetta, remove carbon canister purge line (see page 33)

- Disconnect crankcase breather hoses and vent to atmosphere

Note: On Quantum 5 cylinder, disconnect both crankcase breather hoses from valve cover and plug both T connections at valve cover.

- Connect engine tester using adaptor US1112 and 4 cylinder scale

- Start engine

- Adjust duty cycle of idle air stabilization valve to:

$28\% \pm 1\%$ ($25 \pm 1^\circ$)

RPM should be 800 ± 50 RPM

- Shut off engine

- Reconnect engine tester to continue with ignition timing and CO% adjustments

- Start engine

- Adjust ignition timing

$6^\circ \pm 1^\circ$ BTDC

- Adjust CO%

GTI and GLI — $10\text{mA} \pm 1\text{mA}$ with oxygen sensor connected.

Quantum — $0.8\% \pm 0.2\%$ with oxygen sensor disconnected.

Differential pressure regulator current must correspond to graph. If not, see page 43.

Note: Current reading must fluctuate when oxygen sensor is connected. If not, check oxygen sensor system.

If CO% can not be adjusted to specified range check engine condition (intake leaks, exhaust leaks, etc.).

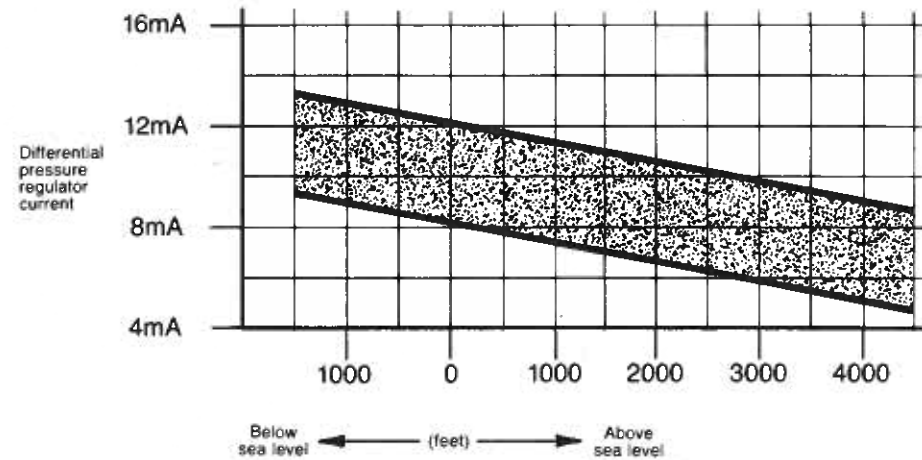

SYSTEM PRESSURE

- Connect VW 1318 pressure gauge between the fuel line at the cold start valve and lower chamber test connection on the fuel distributor
- Use adaptor VW 1318/5 on lower fuel chamber connection

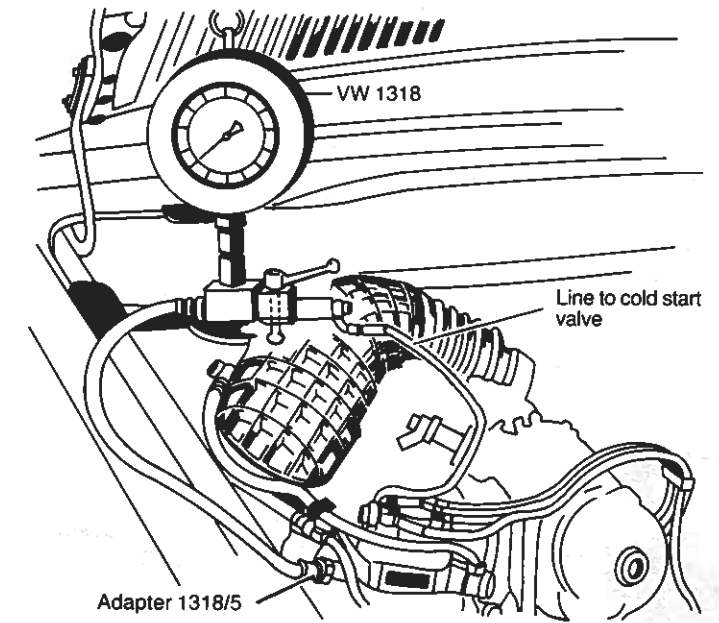
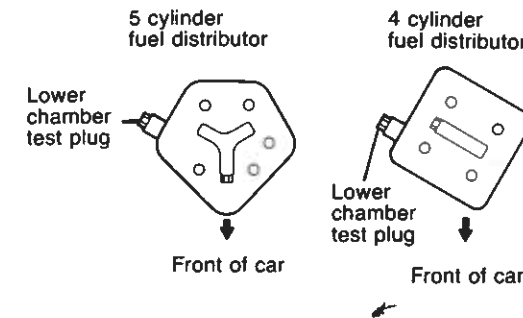

- Remove fuel pump relay and jump socket with US 4480/3
 - Remove wiring connector from differential pressure regulator
 - Open valve on VW 1318 pressure gauge
 - Energize fuel pump
- System pressure should be 5.2 to 5.6 bar (75 to 82 PSI)

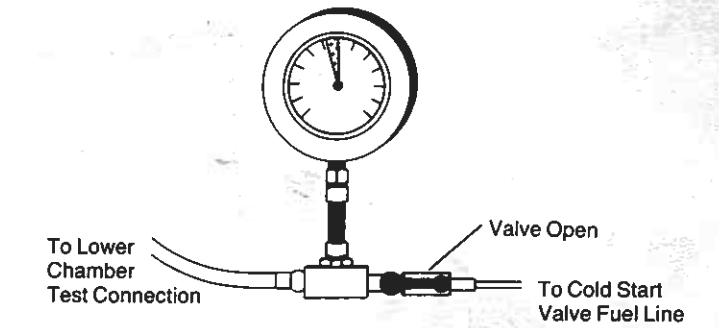

NOTE: System pressure is not adjustable.

- If system pressure is incorrect, check:
 - Fuel pump delivery quantity
 - Fuel supply and return lines for restrictions
 - Fuel filters
- If pressure is still incorrect, replace pressure regulator and retest system pressure

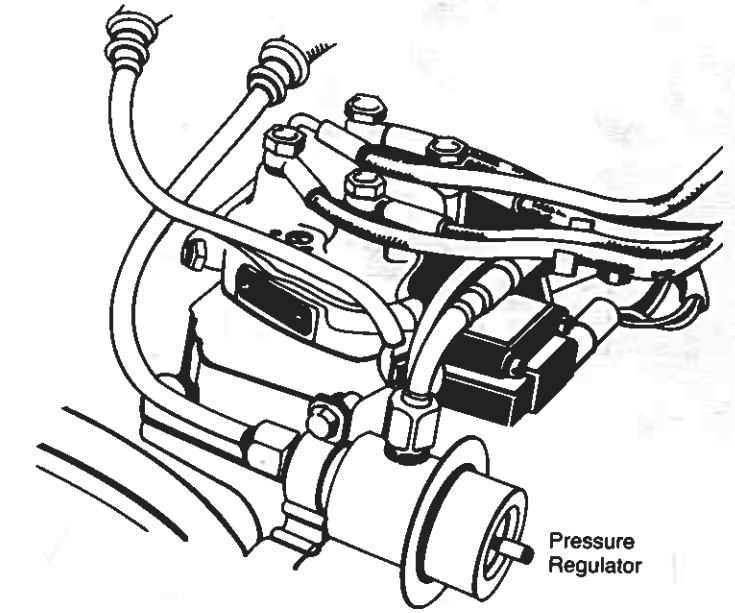

DIFFERENTIAL PRESSURE (PART I)

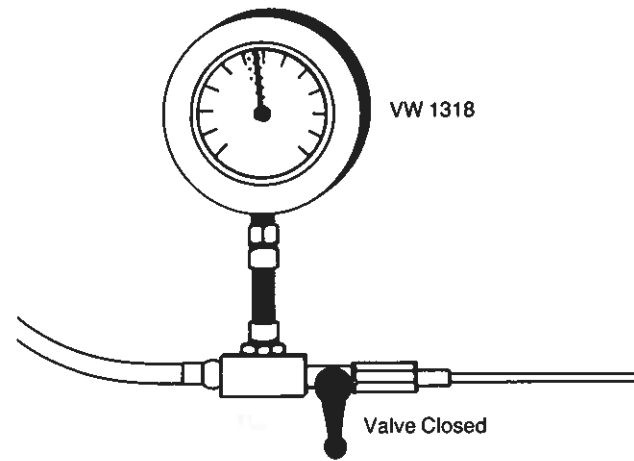

- Close valve on VW 1318 pressure gauge (wiring connector for differential pressure regulator remains disconnected)
- Energize fuel pump
Differential pressure should be 0.2 to 0.5 bar (2.9 to 7.0 PSI) less than previously measured system pressure
- If not within specifications replace differential pressure regulator and retest
- If still not within specifications replace fuel distributor

DIFFERENTIAL PRESSURE (PART II)

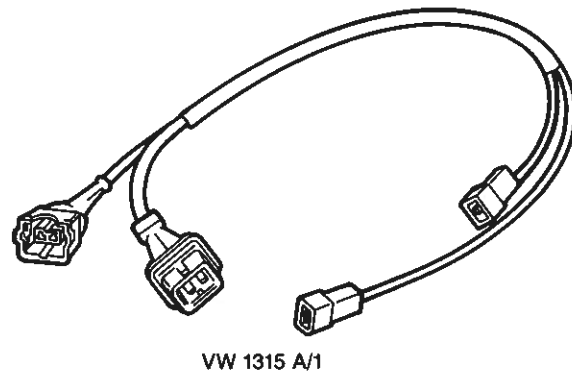

- Connect adapter VW1315 A/1 between differential pressure regulator and wiring connector
- Connect multimeter US1119 to adaptor VW 1315 A/1
Set to 200 mA scale
- Remove wiring connector from engine coolant temperature sensor

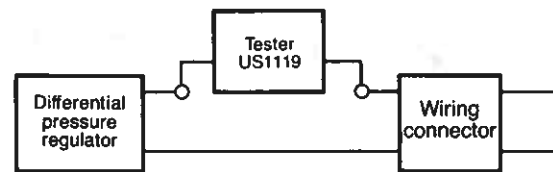

DIFFERENTIAL PRESSURE (PART II) CONTINUED

- Connect 15K Ω side of tool 1490 to temperature sensor wiring connector.
Side remains disconnected
- Turn ignition on
- Energize fuel pump
Differential pressure should be 0.7 to 1.2 bar (10 to 17.5 PSI) less than previously measured system pressure
Differential pressure regulator current should be 50 to 80 mA
- If amperage is within specifications but pressure is not within specifications, replace differential pressure regulator
- If pressure and ampérage readings are not within specifications:
Check ground wire of temperature sensor at cold start valve
If ground is OK, check all electrical connections (see page 58)
If all wiring and connections are OK, replace control unit

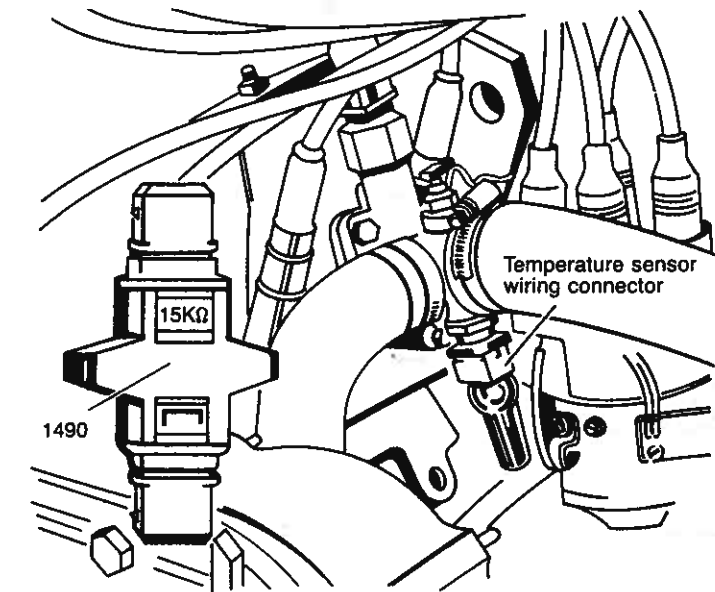

RESIDUAL PRESSURE

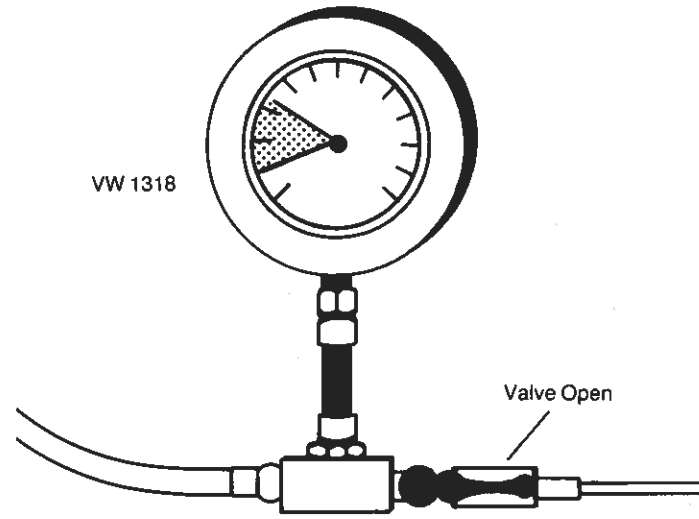

- Open valve of VW 1318
- Energize fuel pump for 30 seconds
- Shut off fuel pump
- Minimum pressure after 10 minutes should be 2.6 bar (38 PSI). If pressure is too low check:
External leaks
Pressure regulator
Fuel pump check valve
Sensor plate adjustment
- Remove fuel pressure gauge and reconnect fuel lines
- Check for leaks

NOTE: On Golf and Jetta, if hot start problem persists with residual pressure OK, replace check valve in fuel pump reservoir. See repair manual group 20.

NOTE: The residual pressure check does not include the cold start valve. To check, reattach fuel line, energize fuel pump, and check valve visually for leaks.

SYSTEM OPERATIONAL CHECKS

WARM-UP ENRICHMENT

- Remove wiring connector from engine coolant temperature sensor and leave disconnected
- Turn ignition on
Differential pressure regulator current should be 80 to 110 mA
- If out of specification, check wiring (see page 58)
- If wiring is OK, replace control unit

COLD ACCELERATION ENRICHMENT

- Engine coolant temperature sensor wiring connector remains disconnected
- Remove intake air boot
- Turn ignition on
- Quickly lift sensor plate fully
Differential pressure regulator should briefly increase, then return back to previous value of 80-110mA
- If reading is not within specifications, check potentiometer operation page 48, and potentiometer wiring
- If wiring and operation are OK, replace control unit

AFTER START ENRICHMENT

- Engine coolant temperature sensor wiring connector remains disconnected
- Ground terminal 4 of ignition coil
- Activate starter for 3 seconds then leave ignition turned ON

Differential pressure regulator current should increase to greater than 120 mA for between 20 and 50 seconds, then decrease to maximum warm-up value (80-110 mA)

- If not within specifications, check for starter signal at control unit
- If signal is OK, replace control unit

FULL THROTTLE ENRICHMENT (QUANTUM 5 CYLINDER, GTI AND GLI)

- Connect \square side of tool 1490 to temperature sensor wiring connector. 15K Ω side remains disconnected
- Disconnect oxygen sensor
- Start engine and accelerate to above 4000 RPM.
Note differential pressure regulator current
- Close full throttle switch by hand

Differential pressure regulator current should increase approximately 4 mA.

- If not within specifications check continuity of full throttle switch and wiring to control unit
- If OK check for speed signal at control unit
- If OK replace control unit

OXYGEN SENSOR CONTROL (ALL 4 CYLINDER ENGINES)

- Bridge engine coolant temperature sensor wiring connector with \square side of tool 1490 15k Ω side remains disconnected
- Disconnect oxygen sensor
- Turn ignition on
Differential pressure regulator current should be 9 to 11 mA

Ground male terminal (green lead) of oxygen sensor

Differential pressure regulator current should be 19 to 22 mA after 20 seconds

- If not within specifications, check wiring from control unit to oxygen sensor
- If wiring is OK, replace control unit

OXYGEN SENSOR CONTROL (QUANTUM 5 CYLINDER ONLY)

- Bridge engine coolant temperature sensor wiring connector with  side of tool 1490 (15KΩ side remains disconnected)
- Disconnect oxygen sensor
- Turn ignition on

Differential pressure regulator current should coincide with graph in relation to surrounding altitude

- Ground male lead (green wire) to oxygen sensor
Differential pressure regulator current should increase 10 mA from previous reading within 20 seconds
- Remove ground connection for oxygen sensor and wait 10 seconds for differential pressure regulator current to stabilize

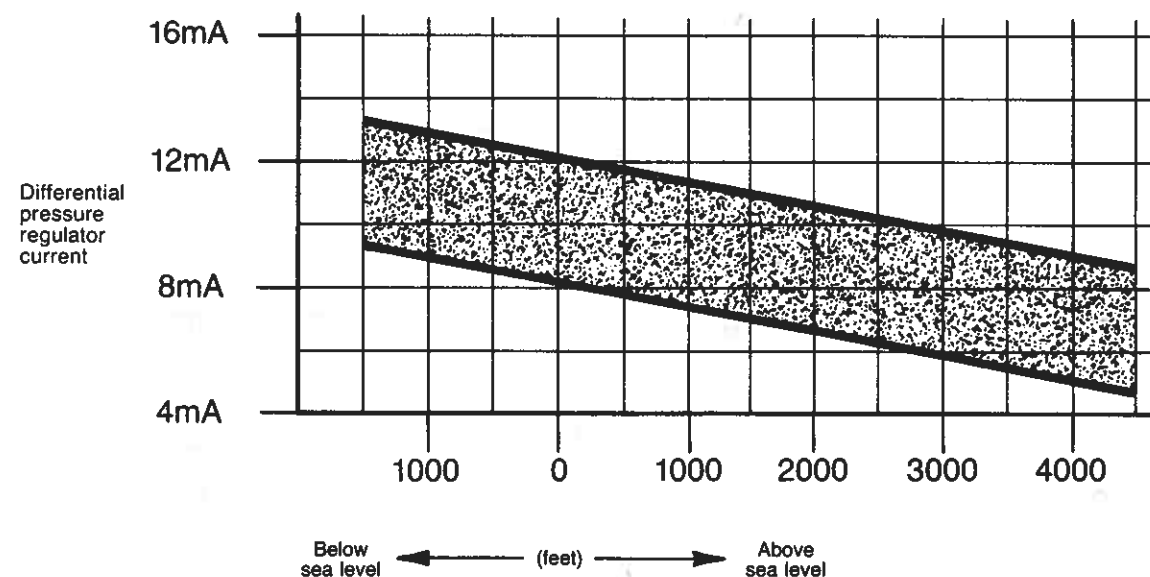

DECELERATION FUEL SHUT-OFF (QUANTUM 5 CYLINDER, GTI AND GLI)

- Start engine and raise speed above 2000 RPM (Engine must be at operating temperature)
- Release throttle

Differential pressure regulator current should briefly go to a negative value (-30 mA to -60mA mA)

- If not within specifications, check idle switch signal at control unit
- If signal is OK, replace control unit

ALTITUDE SENSOR CHECKING (QUANTUM 5 CYLINDER ONLY)

Perform if differential pressure regulator is incorrect based on altitude during test

- Remove wiring connector from differential pressure regulator
- Connect adaptor VW 1315 A/1 and multimeter US 1119 between differential pressure regulator and wiring connector
- Set multimeter to 200mA scale
- Remove fuel pump relay and install US4480/3 in its place
- Remove wiring connector from altitude sensor

Altitude sensor is located near electronic control unit

- Turn ignition on
Differential pressure regulator current should be 10 ± 2 mA
- Connect jumper wire between terminals 1 and 2 on sensor plug
Differential pressure regulator current reads approximately 11-14 mA
- Disconnect jumper wire
- Reconnect jumper between terminals 1 and 3
Differential pressure regulator current reads approximately 0-4 mA
- If readings are OK, replace altitude sensor and adjust CO
- If readings are not OK, check wiring to control unit
- If wiring is OK, replace control unit

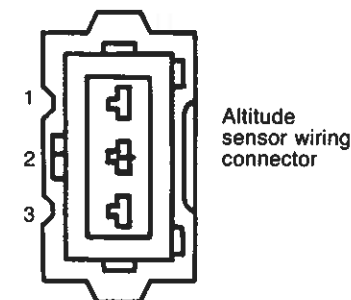

Altitude sensor wiring connector
1 Signal
2 (+) Power
3 (-) Ground

SENSOR PLATE HEIGHT

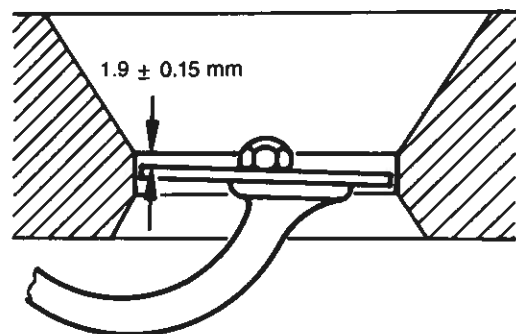

- Run the fuel pump for a few seconds to build up system pressure
- Remove rubber connecting boot from the air sensor housing
- Check position of sensor plate

Upper edge of sensor plate must be $1.9 \pm 0.15\text{mm}$ below the cone edge of the air venturi on the side closest to the fuel distributor

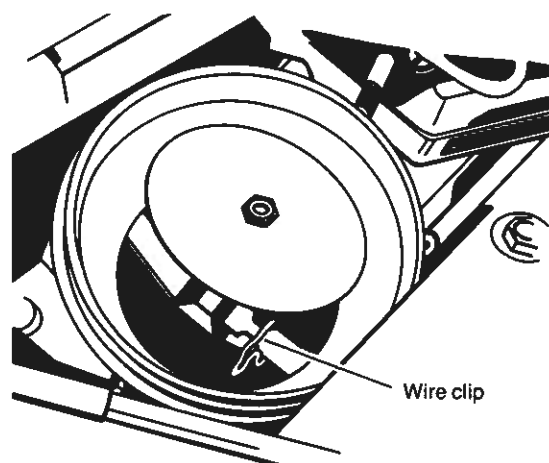

To Adjust:

- Lift sensor plate fully
- Adjust position of sensor plate by bending wire clip

Be careful not to scratch the venturi of the air flow sensor

Do not bend the leaf spring

SENSOR PLATE CLEARANCE

- Lift sensor plate until even resistance is felt

Minimum — noticeable clearance

Maximum — $1.9 \pm 0.15\text{mm}$ (sensor plate even with edge of cone)

- If OK, continue with sensor plate/control plunger movement checks, page 45
- If not OK perform sensor plate lever basic adjustment, page 45

SENSOR PLATE/CONTROL PLUNGER MOVEMENT

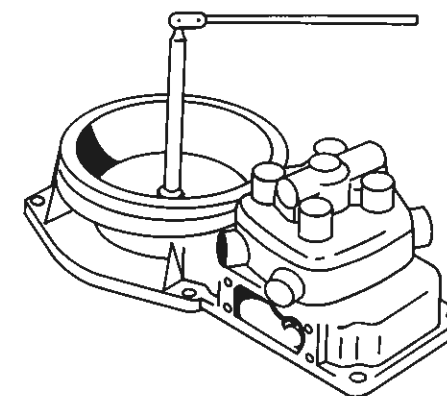

Both the air sensor plate and the control plunger must move freely to insure accurate control of the air fuel mixture. Clean any oil residue from the air sensor plate. (Oil residue can cause the plate to bind.)

- Energize fuel pump for 5 seconds to build up residual pressure then turn pump off
- Using pliers or a magnet, lift sensor plate through entire range of lever and control plunger travel. An even resistance must be felt
- If the plate binds, check the centering of the sensor plate and sensor lever on page 47.
- If OK, replace fuel distributor

SENSOR PLATE LEVER BASIC ADJUSTMENT

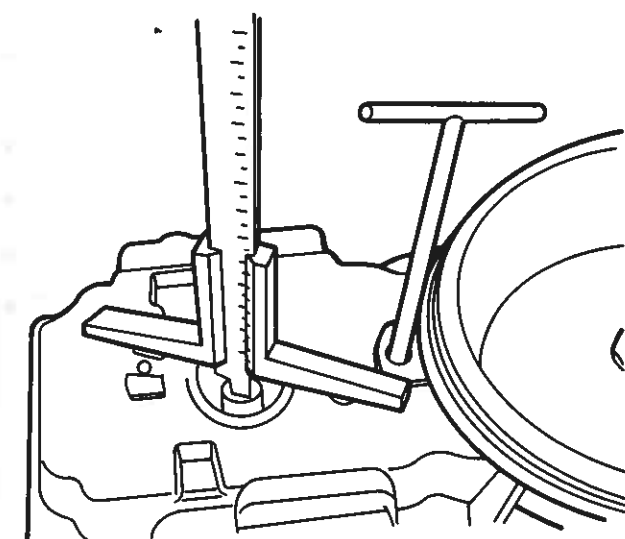

The following adjustment must be made whenever the air sensor housing or the fuel distributor is replaced.

- With fuel distributor removed check distance between seating pads of removed fuel distributor on the air flow sensor and the roller on the sensor plate lever

Distance should be $19.0 \pm 0.1\text{mm}$ (.748 ± .004")

- If measurement is incorrect, adjust CO% adjusting screw to obtain correct specification
 - Reinstall fuel distributor
 - Recheck sensor plate clearance
 - If OK, readjust idle speed and CO%
 - If not OK, remove fuel distributor and adjust sensor plate clearance with stop screw of control plunger
- Clockwise will increase clearance
 Counterclockwise will decrease clearance
- ¼ turn changes sensor plate position approximately 1.3 mm (.050")
- Reinstall fuel distributor and check sensor plate height
 - Readjust idle speed and CO%

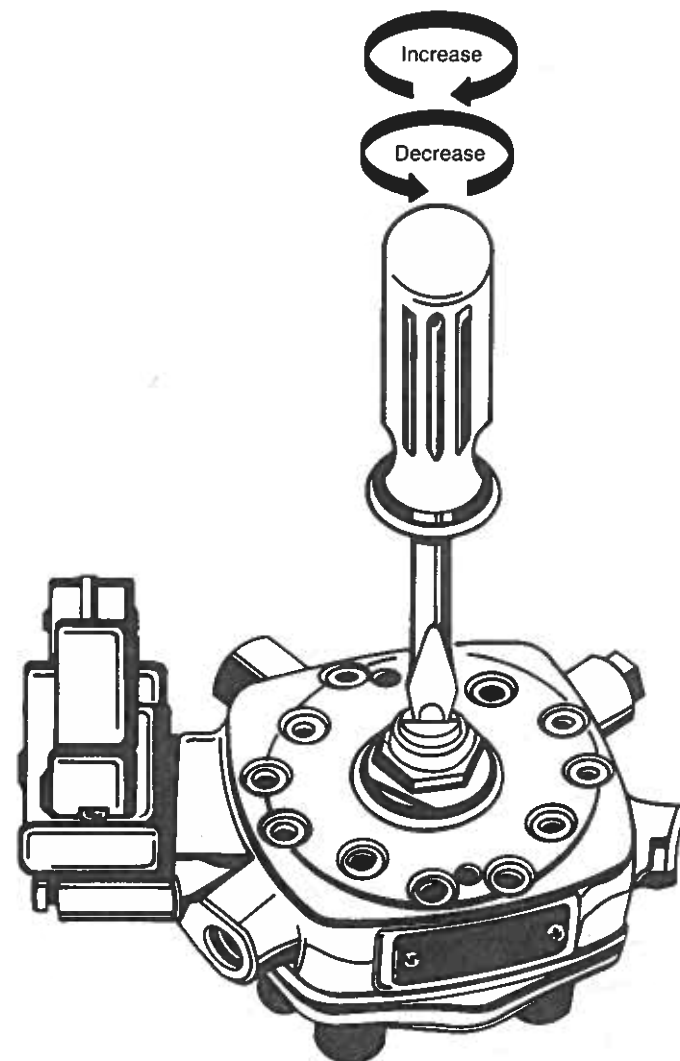

SENSOR LEVER/SENSOR PLATE CENTERING

The sensor plate must be centered in the air cone. The edges must not touch the sides of the air cone or free movement of the plate will be restricted.

TO CENTER THE SENSOR PLATE

- Remove the 10 mm adjusting bolt from the center of the plate
- Coat the bolt with loctite
- Re-install the bolt (finger-tight)
- With centering tool U.S. 1109 or a .10 mm (0.004") feeler gauge, carefully center the plate
- Torque the adjusting bolt to 5-7 Nm (4 ft/lbs.)
- If plate cannot be centered and lever appears to be off center in air cone, remove air sensor housing

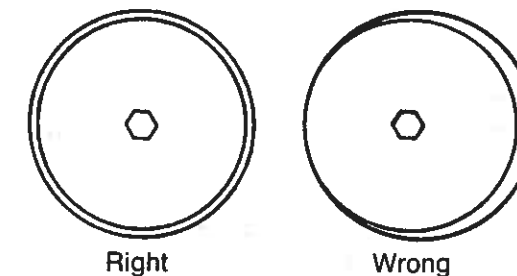

TO CENTER THE SENSOR LEVER

- Remove clamping bolt on sensor lever counter-weight
- Coat the bolt with loctite
- Re-install the bolt (finger-tight)
- Slide lever to center position
- Tighten clamping bolt

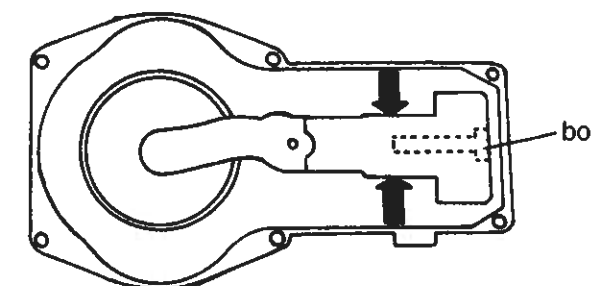

CHECKING

- Remove rubber boot from air sensor housing

NOTE: Before checking the potentiometer, be sure that the sensor plate is adjusted to 1.9 ± 0.15 mm below the edge of the air sensor housing

- Remove wiring connector from sensor plate potentiometer
- Connect adaptor VW 1501 to potentiometer — wiring connector remains disconnected
- Connect multimeter US1119 to adaptor VW 1501 and check resistance value of potentiometer

Between terminals 1 and 2, reading is greater than 4K ohms

Between terminals 2 and 3, reading is less than 1K ohms

- Lift sensor plate evenly

Resistance between terminals 2 and 3 increases up to 4K ohms as plate is lifted

- If any readings are out of specifications, replace potentiometer

NOTE: The potentiometer is factory adjusted and retaining screws are sealed. If replacement is necessary, continue with adjusting procedure.

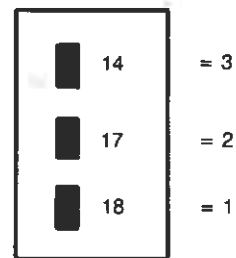
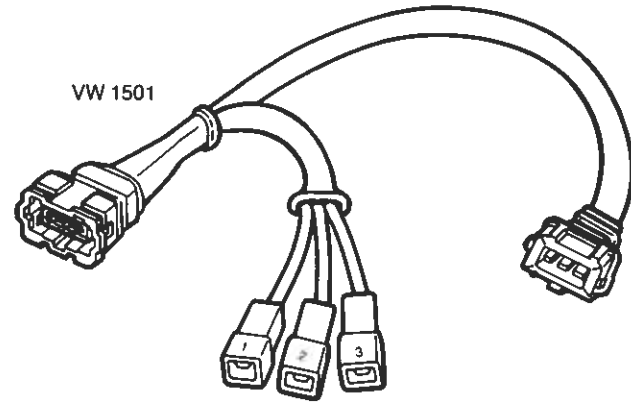

Potentiometer Terminal Designations

ADJUSTING

- Lift sensor plate with VW 1348/1 until it is even with the cone edge of the sensor plate housing air venturi
- Install potentiometer and tighten screws just enough to hold it in position

- Connect adapter VW 1501 between potentiometer and wiring connector

- Connect multimeter US 1119 between terminal 2 and ground

Set to 20 VDC scale

- Turn ignition on

- Adjust potentiometer ←
Voltage read 0.2 to 0.3 volts

- Lift sensor plate fully
Voltage reads approximately 7.0 volts

- Turn ignition off

- Tighten potentiometer screws and seal with sealing compound or paint

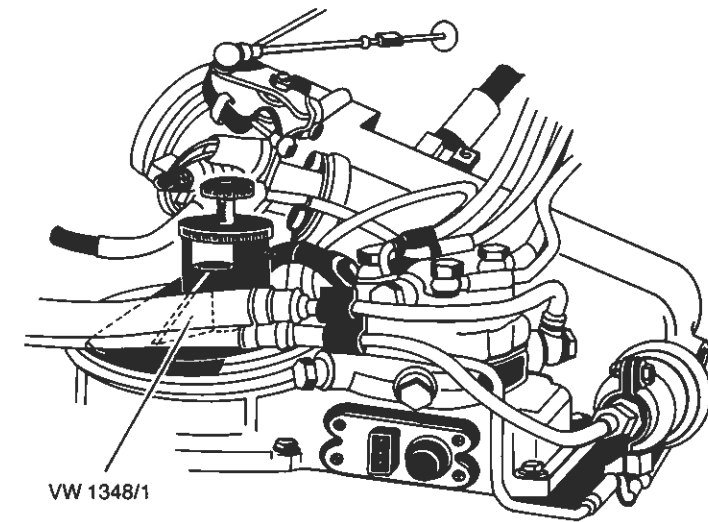

THERMO-TIME SWITCH CHECKING

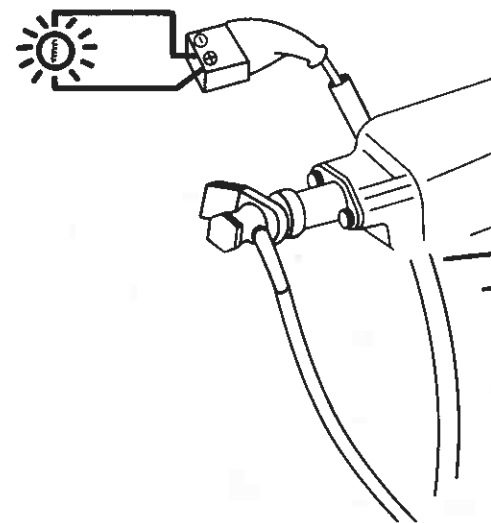

Since the thermo-time switch contact points are designed to open 30°C (86°F) for 4 cylinder engines and 10°C (50°F) for 5 cylinder engines, perform this check only when the thermo-time switch is below the specified value.

- Remove wiring connector from cold start valve
- Ground terminal 4 of ignition coil
- Bridge wiring connector terminals with a test light
- Operate starter

Test light should glow for approximately 1 to 8 seconds and then go out

COLD START VALVE CHECKING

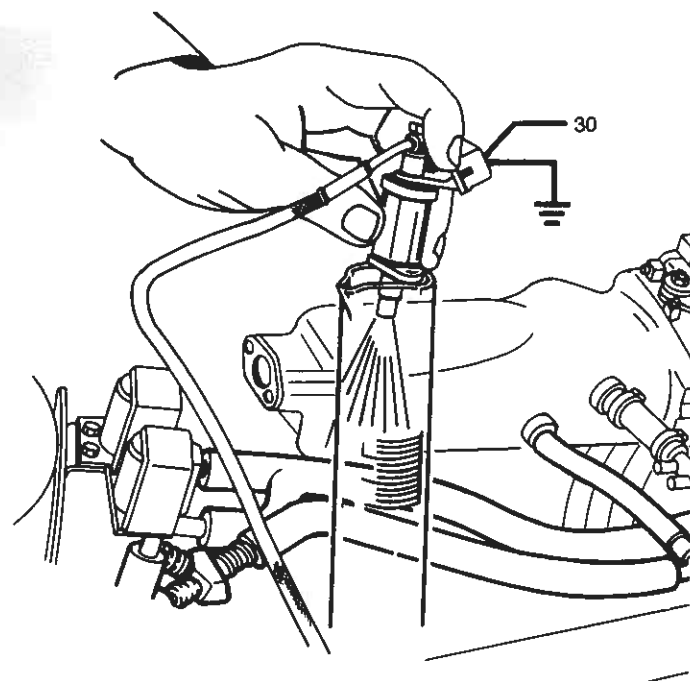

- Remove cold start valve from intake manifold (leave fuel line connected)
 - Remove fuel pump relay and energize fuel pump with US4480/3
 - Connect jumper wire from one terminal of cold start valve to + post of battery
 - Hold valve in container
 - Connect second jumper wire for the other terminal of cold start valve to ground
- Cold start valve should spray in a steady cone shaped pattern
- Disconnect jumper wires
- Cold start valve should not drip within one minute

CHECKING

COLD ENGINE

- Coolant temperature below 30° C (80° F)
 - Remove wiring connector from auxiliary air regulator
 - Start engine and run at idle speed
 - Pinch either hose connected to auxiliary air regulator
- Idle speed should decrease slightly

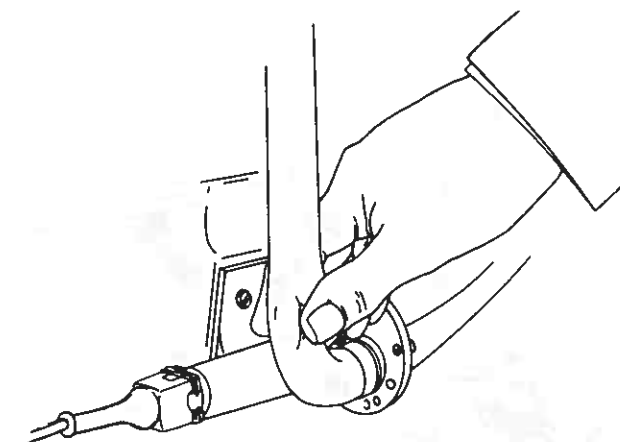

WARM ENGINE

- Wiring connector for auxiliary air regulator connected
 - Start engine and run until it reaches operating temperature
 - Pinch either hose connected to auxiliary air regulator
- Idle speed should not change

VOLTAGE SUPPLY

- Remove wiring connector from auxiliary air regulator
 - Bridge terminals with test light
- If test light glows with engine idling, REPLACE auxiliary air regulator
- If test light does not glow with engine idling, see wiring diagram in repair manual

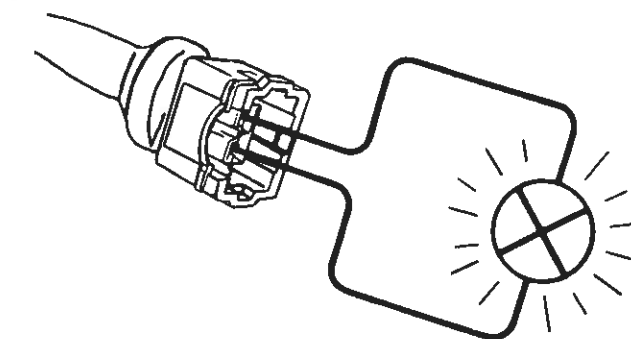

ADJUSTING

Throttle stop screw is set during manufacture and should not be moved. If screw position has been altered, proceed with basic adjustment.

- Turn throttle stop screw counterclockwise until a gap appears between the stop and the adjustment screw
- Turn throttle stop screw clockwise until it touches the stop
- Turn throttle stop screw clockwise an additional 1/2 turn
- Check idle speed and differential pressure regulator current reading
- Readjust idle speed if necessary

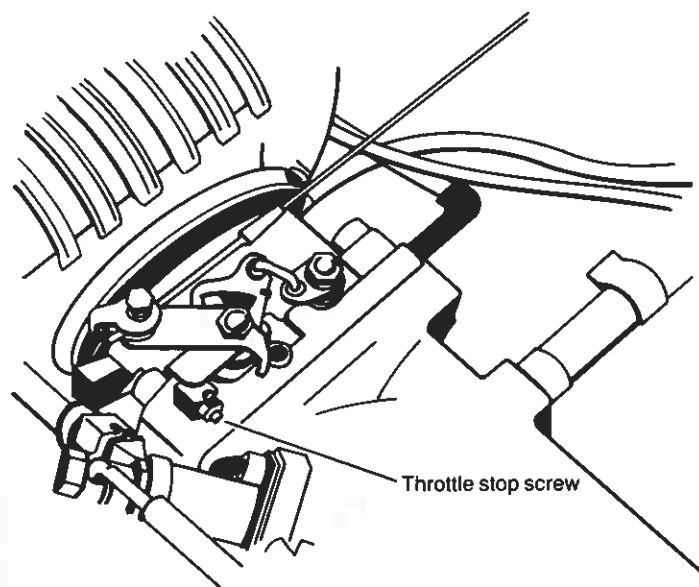

FUEL PUMP DELIVERY RATE CHECKING

- Disconnect fuel return line at fuel distributor
- Place return line in one quart capacity measuring container
- Remove fuel pump relay and install US 4480/3
- Operate pump for exactly 30 seconds
- Delivery quantity should correspond to the graph

If fuel pump delivery is incorrect check:

- Fuel line leaks
- Blocked fuel lines
- Blocked fuel filter
- Blocked fuel tank screen
- Voltage at fuel pump with pump operating

If everything else is OK:

- Replace fuel pump

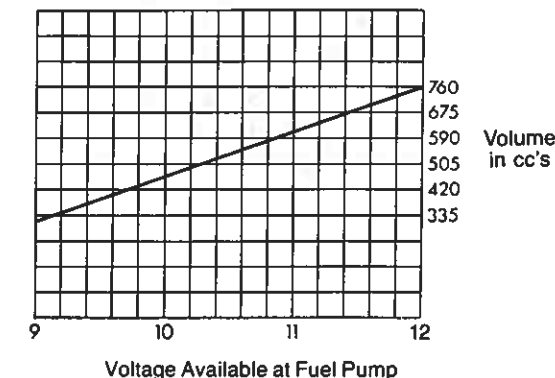
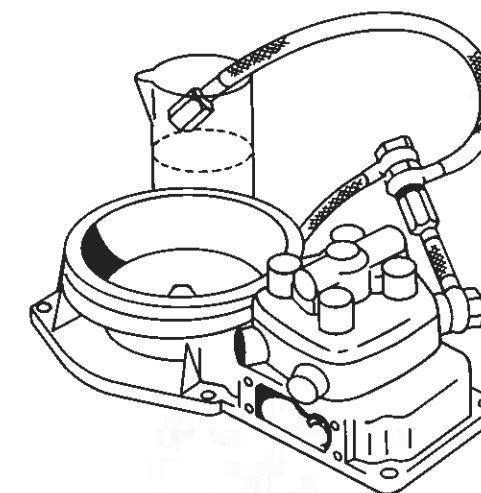

FUEL INJECTORS

Check injector opening pressure and injector leakage:

- Fill bench tester with mineral spirits (Caution — mineral spirits are flammable)
- Connect injector to tester
- Open pressure valve and bleed injector by repeatedly operating tester pump lever
- Measure opening pressure
3.8 to 4.4 bar (55 to 64 PSI)
At 0.5 bar below measured opening pressure — injector should not drip within 15 seconds
- Replace injectors which fail either test.
- Flush new injectors with tester before installing

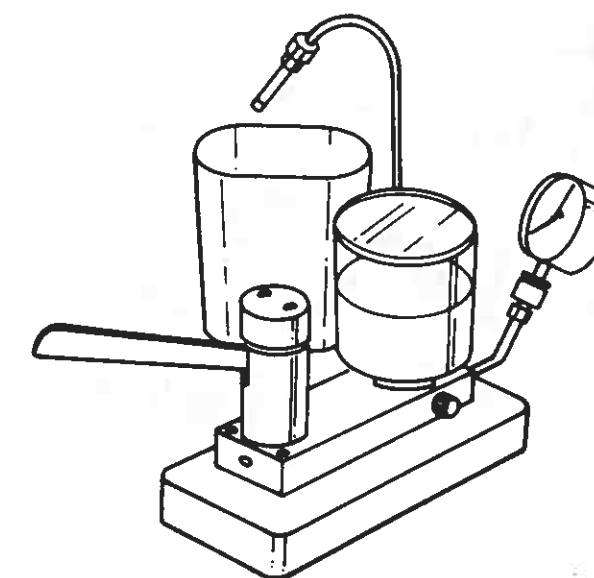

CHECKING

Both the fuel distributor and injectors should supply the same amount of fuel to each engine cylinder. Unequal fuel quantity from either the injectors or the fuel distributor can cause unsatisfactory engine performance.

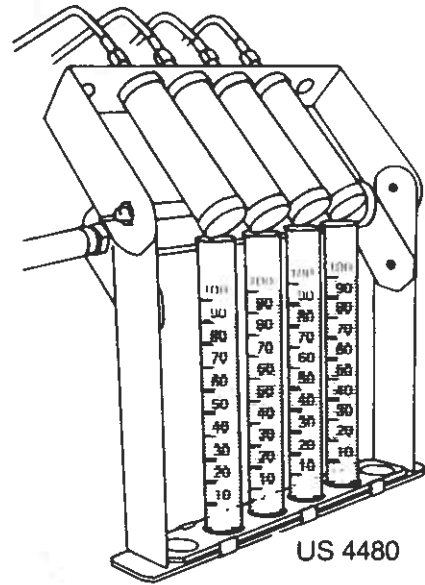

- Remove injectors from cylinder head, leaving fuel lines connected
- Check injector seals for damage and replace any that are defective
- Check tightness of injector inserts with 12 mm allen wrench
- If loose
Remove insert and clean threads
Apply loctite to threads, reinstall and torque to 22 Nm (16 ft. lbs.)
- Remove rubber connector boot from air sensor housing
- Check for correct sensor plate positioning
- Remove fuel pump relay and install US 4480/3 in its place
- Place injectors in US 4480. Insure that fuel lines are not kinked. It may be necessary to loosen fuel line retaining clamp to properly position lines in tester
- Install VW 1348/1 on air sensor
- Turn adjusting screw on VW 1348/1 until magnet just contacts the bolt on the sensor plate
- Energize fuel pump
- Turn adjusting screw on VW 1348/1 counterclockwise until at least one injector just begins to spray
- Turn off fuel pump and empty US 4480

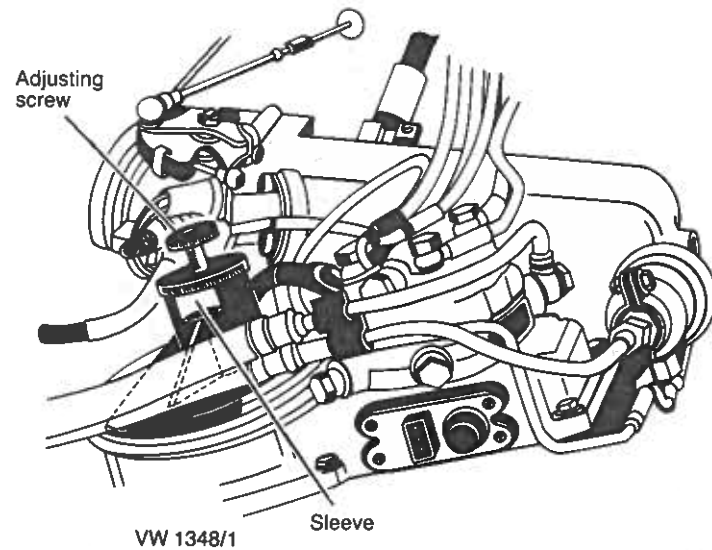

IDLE TEST

- Lift sleeve of VW 1348/1 to first stop, simulating idle
- Allow fuel pump to run until the fuel level in any of the cylinders of US 4480 reaches 20 ml
- Note injection spray pattern
Must be even and cone shaped
All injectors should have the same pattern
- Shut off fuel pump
- Difference between highest and lowest cylinders
3 ml or less
- Empty US 4480

FULL THROTTLE TEST

- Lift sleeve on VW 1348/1 to last stop, simulating full throttle
- Run fuel pump until any of the cylinders of US 4480 is filled to 80 ml

- Note injector spray pattern
Must be even and cone shaped
All injectors should have the same spray pattern
- Shut off fuel pump
- Difference between highest and lowest cylinders
8 ml or less
- If difference between the volume is excessive in either test
- Interchange the injectors on the two fuel lines with the widest variation
- Repeat volume test
- If the same fuel line shows low volume on the second test, the fuel line is pinched or the fuel distributor is defective
- If the same injector shows the low volume on the second test, that injector is defective

CHECKING QUANTUM 5 CYLINDER, GTI AND GLI

Siemens 451 or VW 1367

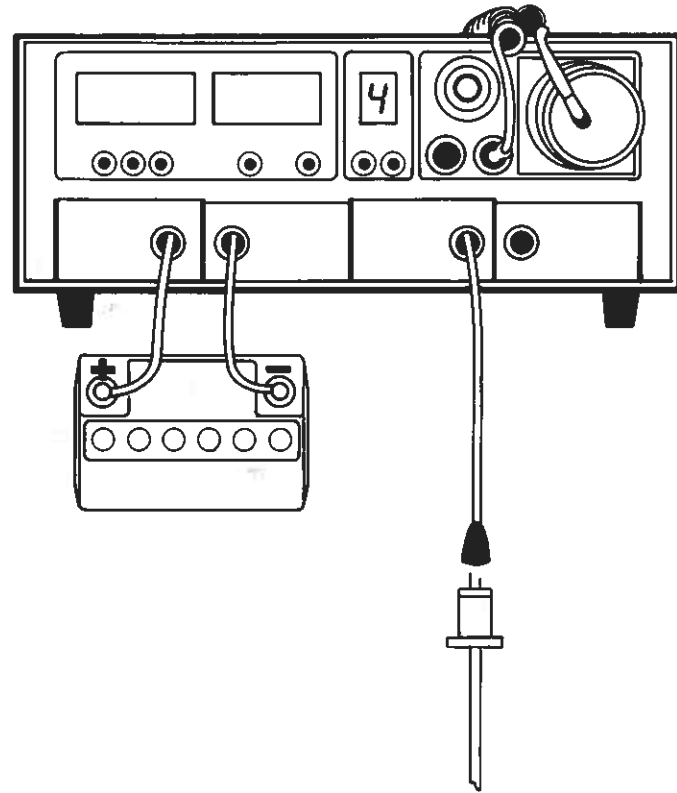

- Connect engine tester to test plug using adaptor US1112 and set tester to 4 cylinder scale

NOTE: Only connect the (+) and (-) and (dwell) leads of VW 1367 or Siemens 451. If other test leads are connected the "duty cycle" readings will be inaccurate.

- Ground terminal 4 of ignition coil
- Disconnect wiring connector from engine coolant temperature sensor and leave disconnected
- Operate starter for about 3 seconds
Dwell reading should be about 60% (54°) during cranking
- Connect  side of tool 1490 adaptor to engine coolant temperature sensor wiring connector
- Reconnect terminal 4 of ignition coil
- Start engine and raise engine speed slightly (To open idle switch)
Dwell reading should be about 32% (29°)
- Return engine to idle speed
- Turn on air conditioning
With A/C compressor engaged idle speed should be 900 ± 20 RPM
- If not within specifications, check engine mechanical condition and check for vacuum leaks
- If OK, check wiring for idle air stabilization system
- If wiring is OK, replace control unit and retest
- If not OK, replace idle air stabilization valve

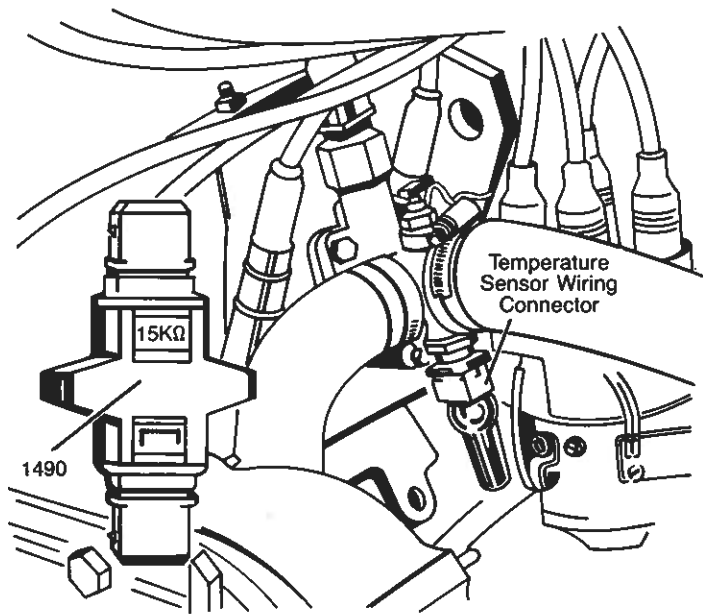

The entire fuel injection electrical system can be tested from the disconnected control unit plug.

- Before disconnecting multi-point connector of control unit check:
 - Ground connection on cold start valve
 - Resistance value of differential pressure regulator
 - Potentiometer resistance values
 - Temperature sensor resistance value
 - Disconnect multi-point connector from control unit. Wiring connectors on all electrical components must be connected
- Caution**—Disconnect and connect control unit multi-point connector only with ignition off.
- Perform electrical tests in order shown on trouble shooting procedure sheet using test leads with *flat ends only!* Anything else could damage the multi-point connections

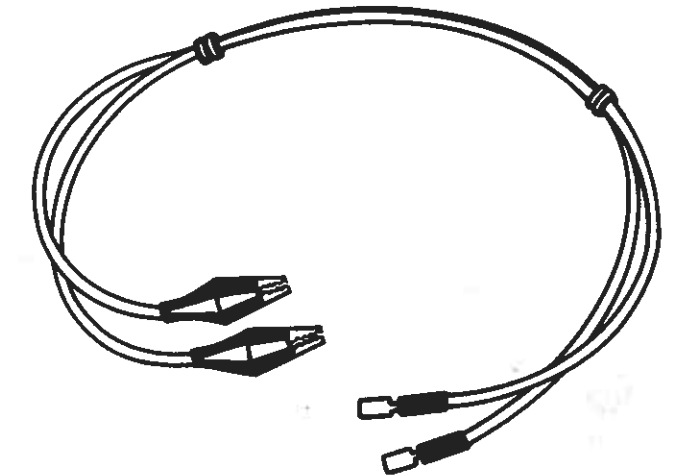

Test Leads can be made locally using the following materials:

1. 2 flat male plugs N 17.457.2
2. 2 super flexible leads, each approx. 60 cm long
3. 2 insulated alligator clips

ALL VEHICLES

Terminal #	Procedure	Result	Item Tested
1 + 2	Turn ignition ON	Battery voltage	Fuse Power supply to terminal 1 Ground connection at terminal 2
24 + 2	Ground terminal 4 of ignition coil and activate starter	Cranking voltage (min. 8v)	Starter signal to terminal 24 of control unit from starter terminal 15A
7 + 2		∞ ohms	Oxygen sensor shield
8 + 2	Disconnect oxygen sensor wire and ground green lead	0 ohms	Wire to oxygen sensor
10 + 12		17 to 22 ohms	Differential pressure regulator
17 + 18		greater than 4 K ohms	Sensor plate potentiometer
14 + 17		greater than 1 K ohms	Sensor plate potentiometer
14 + 17	Lift sensor plate	greater than 4 K ohms	Sensor plate potentiometer
21 + 2		Resistance corresponds to curve, See page 23. 0 (32°F) = 6.0 K ohm 20 (68°F) = 2.5 K ohm 80 (176°F) = 300 ohm	Temperature sensor

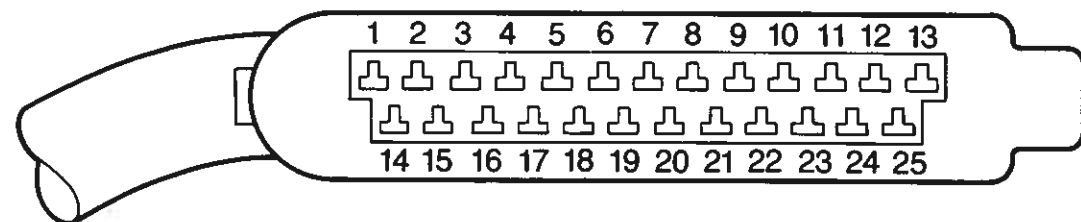

Control unit plug

ADDITIONAL TESTS FOR QUANTUM 5 CYLINDER, GTI AND GLI

Terminal #	Procedure	Result	Item Tested
13 + 2	Ignition ON Idle switch closed	Battery voltage	Idle switch
5 + 2	Ignition ON Full throttle switch closed	Battery voltage	Full throttle switch
25 + 2	Crank engine	4 to 8 volts	Engine speed signal from ignition control unit
20 + 2		0 ohms	Ground connection at terminal 20
3 + 4		24 to 30 ohms	Idle air stabilization valve
1 + 4		12 to 15 ohms	Idle air stabilization valve
1 + 3		12 to 15 ohms	Idle air stabilization valve
16 + 2	Ignition ON A/C switch ON Compressor engaged	Battery voltage	Signal from A/C switch
19 + 2	Ignition ON A/C switch ON Compressor engaged	Battery voltage	Signal from A/C compressor

ALL 4 CYLINDER ENGINES EXCEPT GTI AND GLI

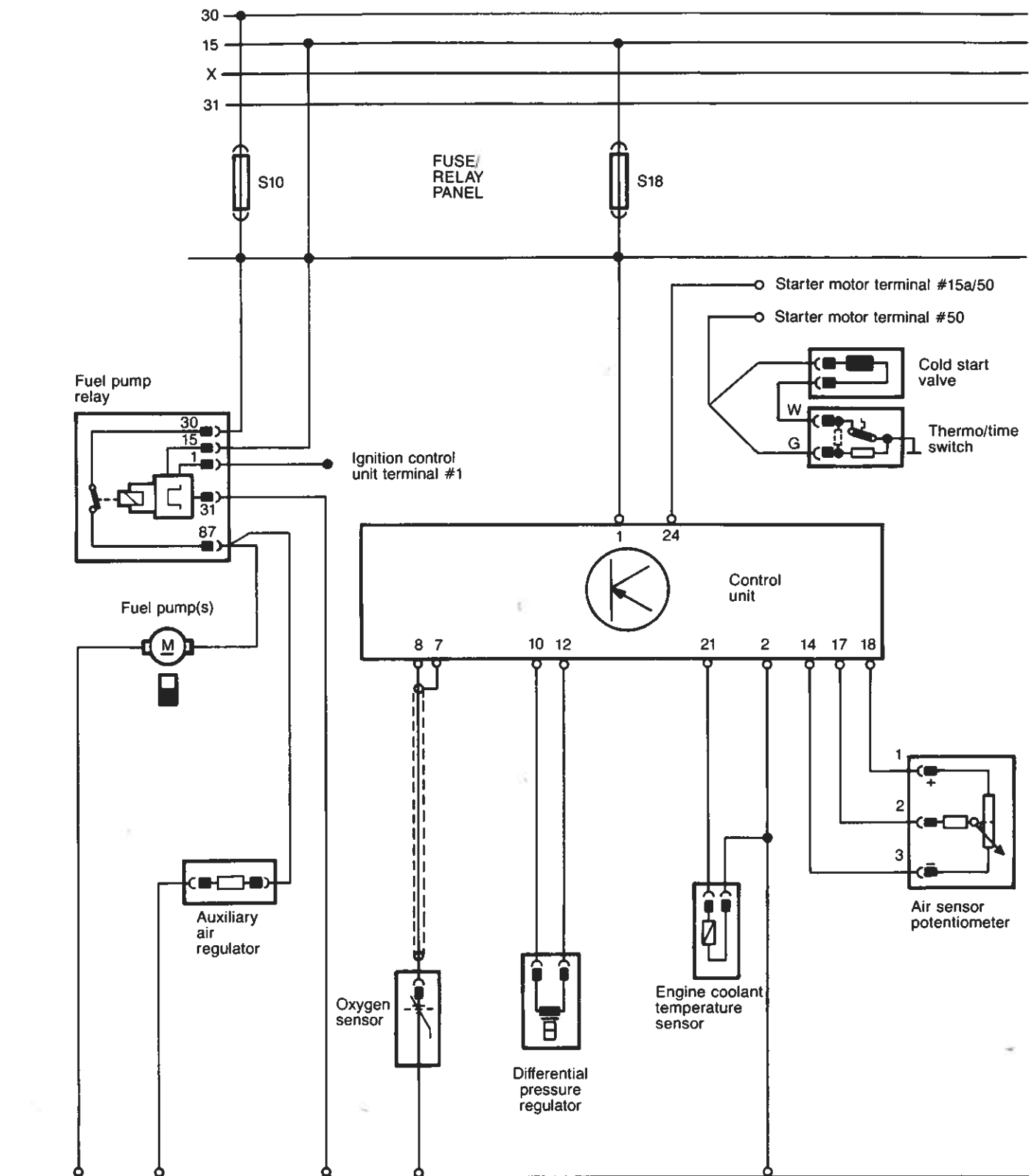

GTI AND GLI

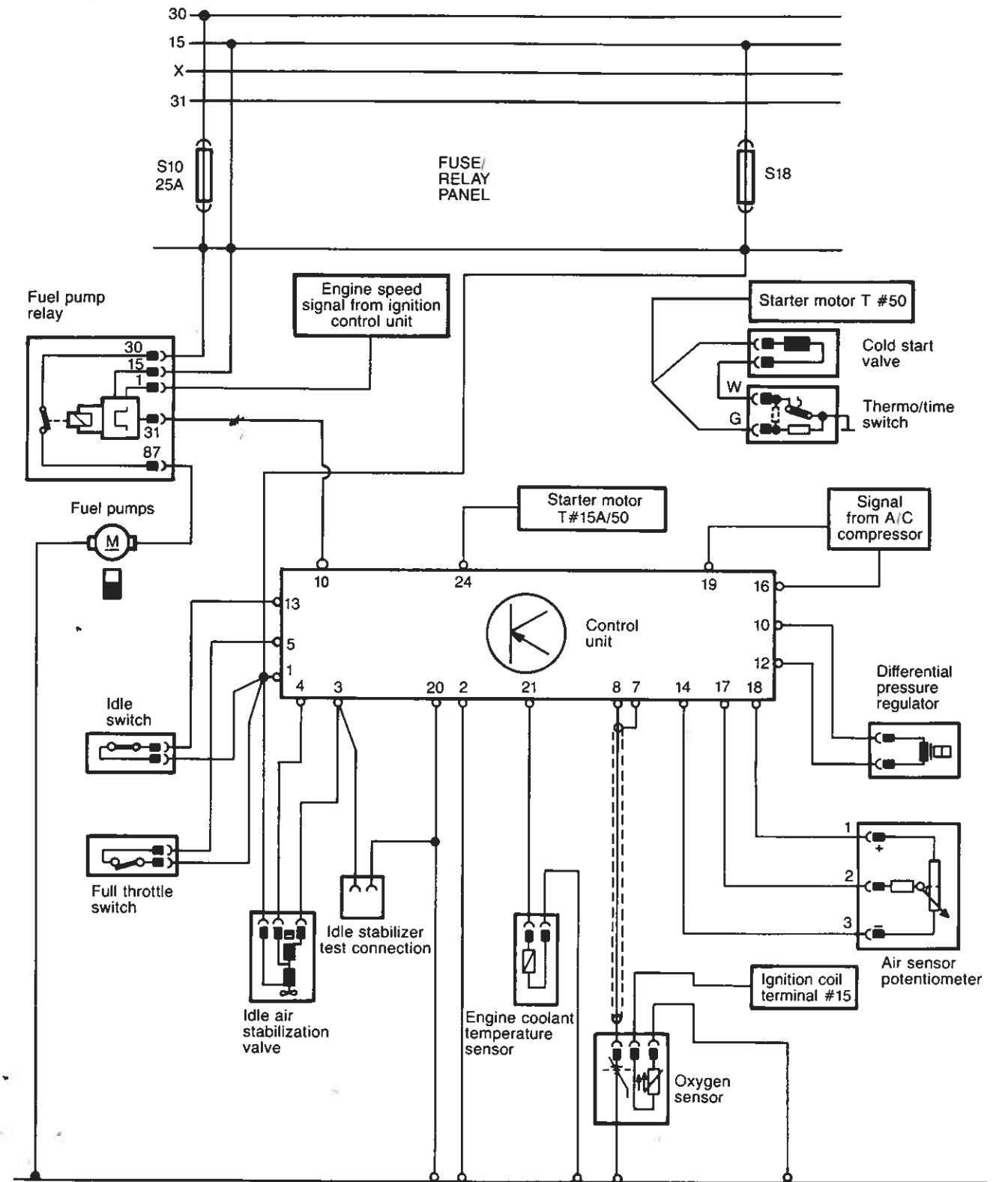

QUANTUM 5 CYLINDER

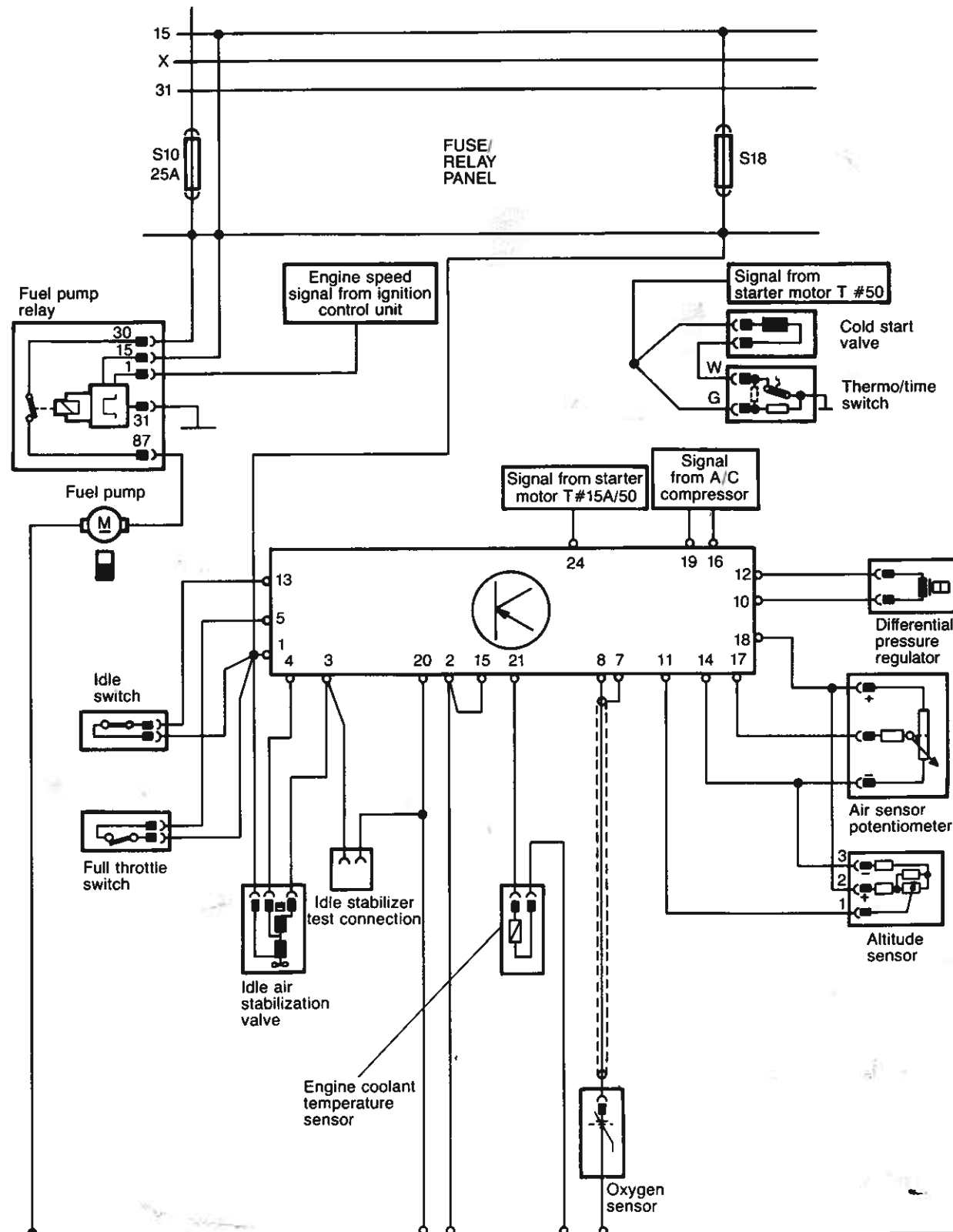

AIR SENSOR — An air cone with a floating plate which measures air flow and determines control plunger position.

AUXILIARY AIR REGULATOR — A rotary-gate valve which stabilizes idle speed during engine warm-up.

BAR — Unit of measurement for fuel pressure — 1 bar is about 14.5 PSI.

COLD START VALVE — A solenoid valve for fuel enrichment during cold starts.

CONTROL PLUNGER — A single piston valve in the fuel distributor which controls fuel flow to the injectors.

COOLANT TEMPERATURE SENSOR — A sensor for measuring engine coolant temperature to determine cold running engine operation.

DIFFERENTIAL PRESSURE — The difference in pressure between the upper and lower chambers of the fuel distributor.

DIFFERENTIAL PRESSURE REGULATOR — An electronically controlled valve (actuator) which regulates fuel flow to the lower chamber of the fuel distributor.

FUEL ACCUMULATOR — Diaphragm unit which helps maintain residual fuel pressure for good hot starting.

FUEL FILTER — A filter which removes foreign particles from the fuel system.

FUEL PUMP — An electric pump which delivers fuel to the fuel distributor.

IDLE AIR STABILIZATION VALVE — Electronically controlled valve used to maintain idle speed at a pre-determined level.

INJECTOR — A pressure-activated valve which directs a cone shaped mist of fuel into the intake port near each intake valve.

OXYGEN SENSOR — Device used to detect the amount of oxygen in the exhaust gases.

PRESSURE REGULATOR — A diaphragm type regulator used to maintain system pressure at a given value.

POTENTIOMETER — A variable resistor connected to the air flow sensor that provides a signal for determining fuel system enrichment.

RESIDUAL PRESSURE — Pressure remaining in the fuel system after the engine has been shut off.

SENSOR PLATE — A round plate bolted to the air sensor lever which floats in the stream of intake air.

SYSTEM PRESSURE — Fuel pressure in the fuel distributor controlled by the pressure regulator.

1. ABOUT

...

10

...

...

...

...

10

10

...

...

...